

NOTES

1. MATERIAL: HEAT SHRINKABLE BOOT MATERIAL IN ACCORDANCE WITH NEMOSYNE FR/M. THIS INCLUDES INTERNAL COATING OF FACTORY APPLIED NON-SETTING SEALANT. BOOTS ARE AVAILABLE WITHOUT SEALANT ON SPECIAL ORDER.

2. PART IS TO BE MARKED ON 3 SIDES AS INDICATED WITH "100 AMP MAX" IN M-149 SP ORANGE OFFSET INK; MATTHEWS INTERNATIONAL CORP. PART NUMBER 10006-94L-05.

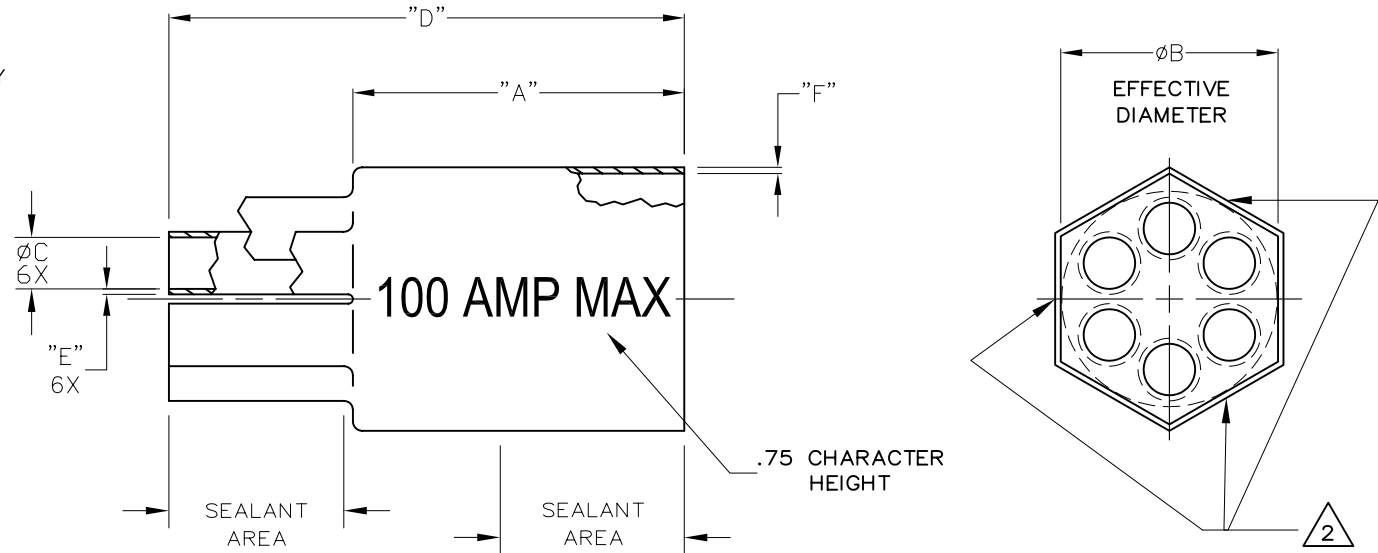

REVISIONS		
LTR	DESCRIPTION	DATE
1	PRELIMINARY	04/09/2008

If this document is printed it becomes uncontrolled. Check for the latest revision

PART DESCRIPTION	"A"		ØB		ØC		"D"		"E"	"F"
	MIN EXP	MAX REC	MIN EXP	MAX REC	MIN EXP	MAX REC	MIN EXP	MAX REC	MAX REC	MAX REC
6S100-200-FR-01	3.09 [78,49]	3.57 [90,68]	2.40 [60,96]	1.45 [36,83]	.80 [20,32]	.35 [7,62]	5.22 [132,59]	6.62 [168,15]	.10 [2,54]	.15 [3,81]

**PRELIMINARY**

CUSTOMER DRAWING

UNLESS OTHERWISE SPECIFIED DIMENSIONS ARE INCHES. METRIC DIMENSIONS ARE IN BRACKETS.  DECIMAL TOLERANCES .XXX ± 0.005 [0.13 mm] .XX ± 0.01 [0.25 mm] .X ± 0.1 [0.50 mm]  ANGLE TOLERANCE .X ± 1 DEG.	DRAWN LUNGUEN	DATE 04/09/2008	 Raychem Molded Parts 305 Constitution Dr Menlo Park, CA 94025
	RPN 455173N002		
THIRD ANGLE PROJECTION		SIZE B	CODE IDENT. NO. 06090
© 2008 Tyco Electronics Corporation. All rights reserved.		DWG. NO. 6S100-200-FR-01	
DD NOT SCALE THIS DRAWING		SHEET 1 OF 1	