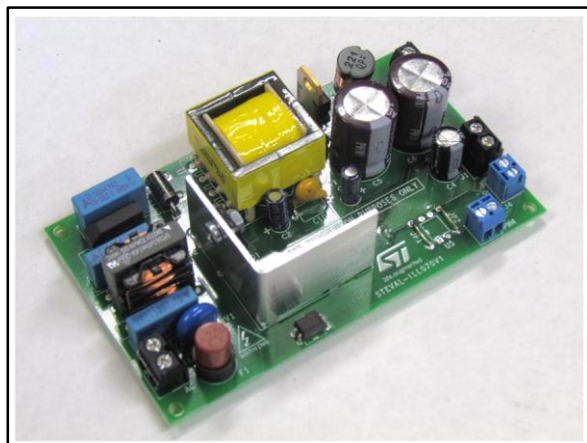

35 W, 0-10 V dimmable single-string LED driver based on the HVLED001 quasi resonant flyback controller

Data brief

**Features**

- Input voltage: $V_{IN} = 90$ to $305 V_{rms}$, 45 to 66 Hz
- Output current: 700 mA ($V_{LED} = 0$ to 48 V)
- Dimming: 100% to 10% (any condition)
- Dimming interfaces: 0 to 10 V and PWM input
- High power factor, low THD
- Efficiency: > 90% @ full load
- No-load: better than 300 mW @ 230 V_{IN}
- Open load voltage limiting
- RoHS compliant

Description

The STEVAL-ILL070V1 is an evaluation platform that drives a single LED string with a maximum output current of 700 mA. The LED current can be finely adjusted using either a 0 - 10 V interface or a PWM signal (provided by a microcontroller, for example) on the SELV portion of the board. The extremely wide output voltage range and the universal input capability make this board very flexible. An auxiliary 12 V output is also present to supply small circuitry (e.g. a potentiometer to drive the 0 - 10 V input) providing a maximum current of 10 mA. A very high power factor and high efficiency are obtained thanks to the HVLED001 features. Input voltage variations, excessive input voltage (overvoltage such as surges or bursts) or very low input voltages are managed by the HVLED001's protection features, improving the reliability of the application. Output open-circuit and overload protection are auto-restarted for safe operation in lighting environments.

1 STEVAL-ILL070V1 board layout

Figure 1: Location of jumpers and connectors

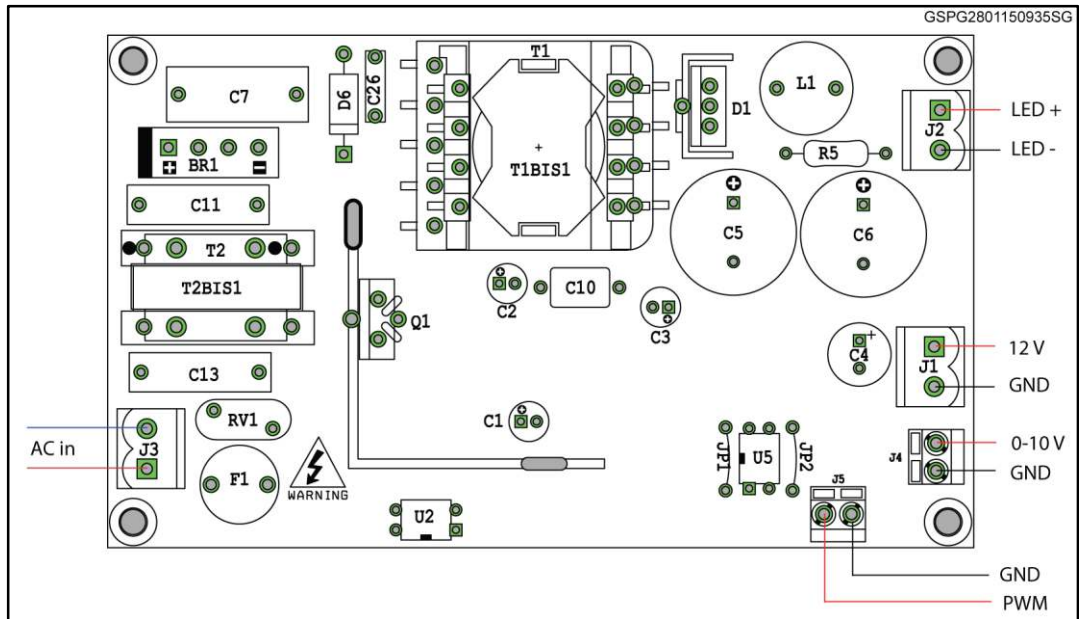

2 Schematic diagrams

Figure 2: STEVAL-ILL070V1 circuit schematic - constant current regulation section

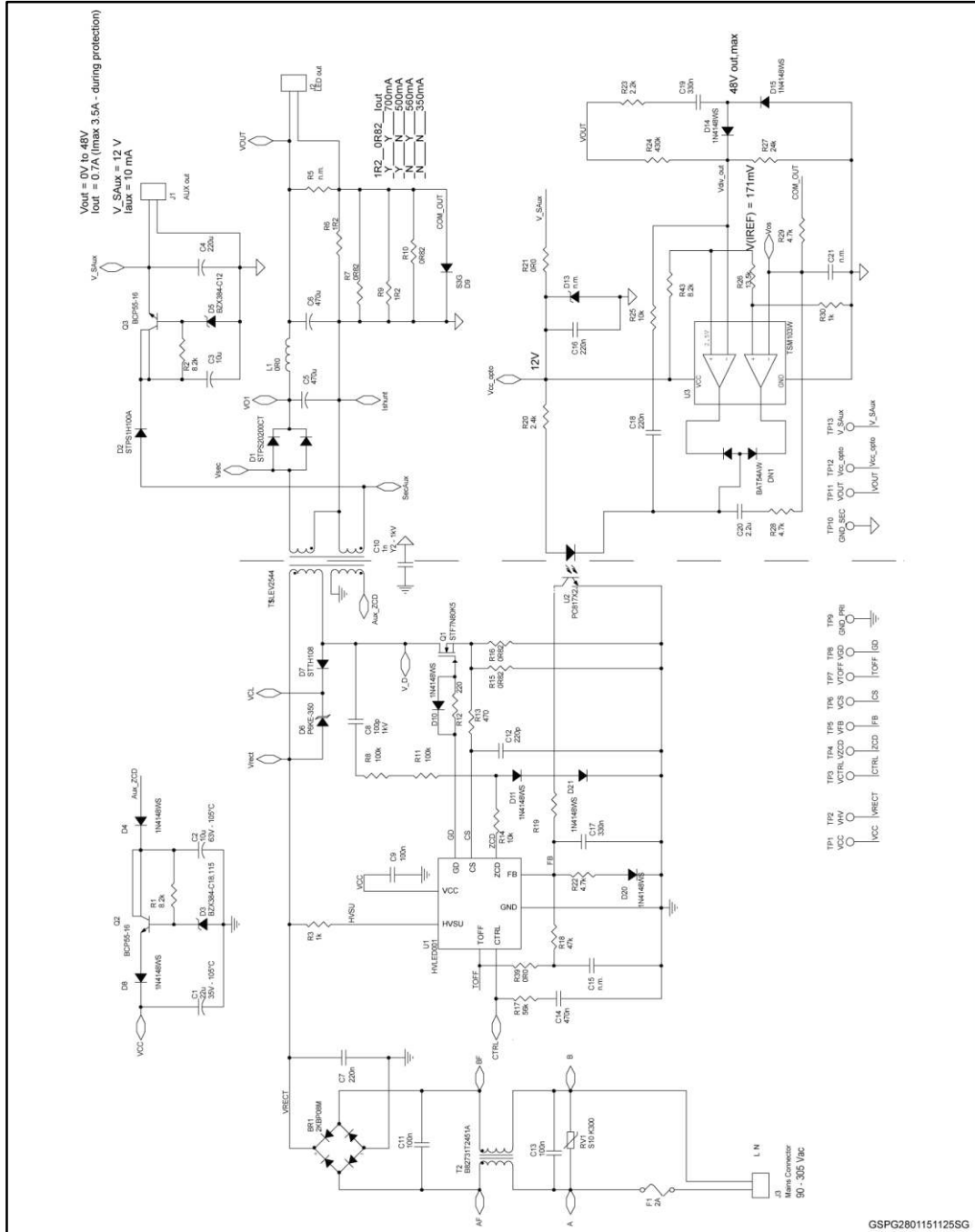
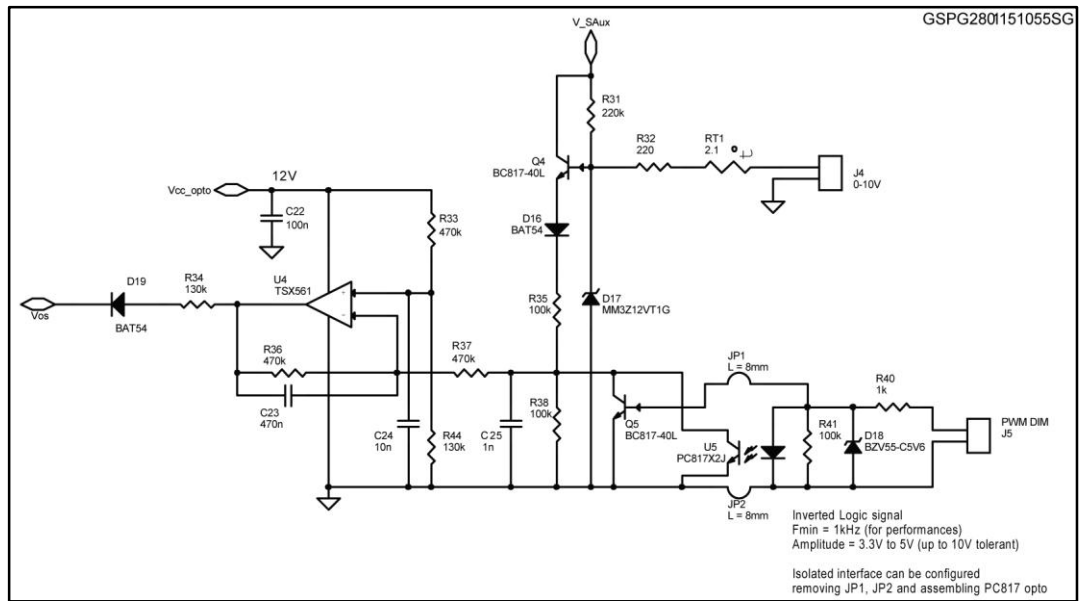

Figure 3: STEVAL-ILL070V1 circuit schematic - dimming interface section



3 Revision history

Table 1: Document revision history

Date	Rev	Changes
02-Feb-2015	1	First release.

IMPORTANT NOTICE – PLEASE READ CAREFULLY

STMicroelectronics NV and its subsidiaries ("ST") reserve the right to make changes, corrections, enhancements, modifications, and improvements to ST products and/or to this document at any time without notice. Purchasers should obtain the latest relevant information on ST products before placing orders. ST products are sold pursuant to ST's terms and conditions of sale in place at the time of order acknowledgement.

Purchasers are solely responsible for the choice, selection, and use of ST products and ST assumes no liability for application assistance or the design of Purchasers' products.

No license, express or implied, to any intellectual property right is granted by ST herein.

Resale of ST products with provisions different from the information set forth herein shall void any warranty granted by ST for such product.

ST and the ST logo are trademarks of ST. All other product or service names are the property of their respective owners.

Information in this document supersedes and replaces information previously supplied in any prior versions of this document.

© 2015 STMicroelectronics – All rights reserved