

© COPYRIGHT 1969 BY AMP INCORPORATED, HARRISBURG, PA.  
ALL INTERNATIONAL RIGHTS RESERVED. AMP INCORPORATED PRODUCTS  
COVERED BY U. S. AND FOREIGN PATENTS AND/OR PATENTS PENDING.

REVISIONS						
P	F	ZONE	LTR	DESCRIPTION	DATE	APPROVED
✓			G	REV PER ECN CM 54	10/30/84	TB/RS
✓			G1	RESTORED	4/23/85	mc/K
✓			H	OBSOLETE-2 PER CM-868	5-26-87	PKC/TB
✓			J	REVISED PER CM-1467	1-14-88	PKC/RS
			K	REV PER 0710-0427-95	3/27/95	pmf

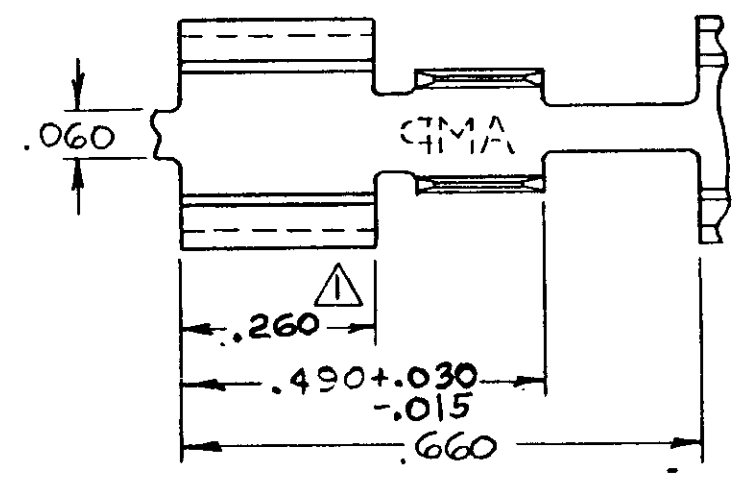

⚠ CHECK ROUNDNESS AT THE WIRE BARREL END.

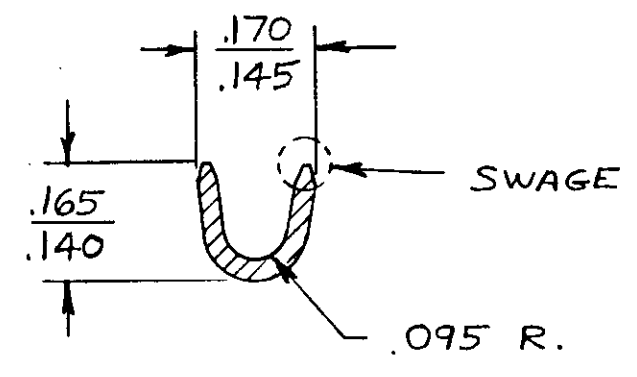
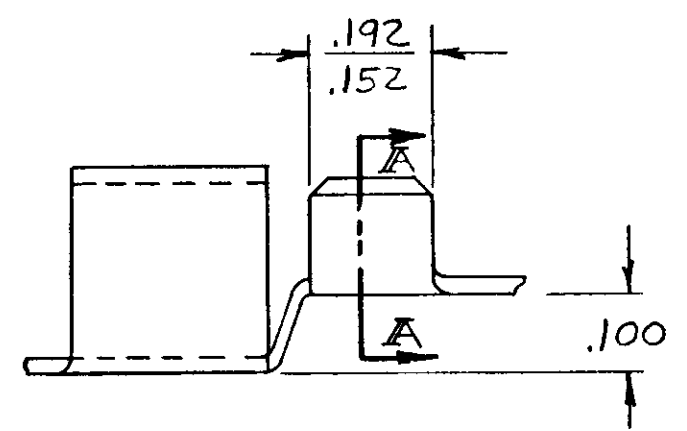
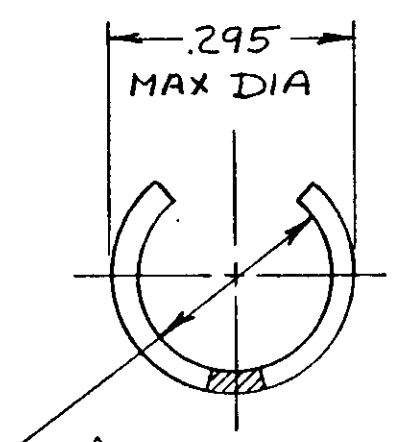

SECTION A-A

⚠  
.239 DIA PIN MUST ENTER  
.247 DIA PIN MUST HOLD  
.100 GM. WEIGHT.  $\frac{.245}{.241}$  DIA.  
0.003

	.020 BE.CU.	NICKEL PL.	16-14 AWG.	61792-1
	MATERIAL	FINISH	WIRE RANGE	PART NO
UNLESS OTHERWISE SPECIFIED DIMENSIONS ARE IN INCHES. TOLERANCES ON: DECIMALS ±.015 ANGLES ± 1°	CONTRACT NO	AMP INCORPORATED Harrisburg, Pa.		
	DR 2-28-80 D.A. SALTZER			
MATERIAL	CHKD D.S. Heide 2/28/80	NAME		
SEE TABLE	APPD [Signature]	RECEPTACLE, .250 FUSE		
FINISH	APPD	SIZE	CODE IDENT NO	DRAWING NO
SEE TABLE	DSGN APPD	B	00779	61792
	OTHER APPD	SCALE 4:1		SHEET