

REVISIONS						
LOC	DIST	P	LTR	DESCRIPTION	DATE	APVD
-	-	H		REVISED PER E.O. P17744	11DEC2002	RDR
		J		REVISED PER E.O. P19419	11DEC2006	RDR
		K		REVISED PER E.O. P21366	4JUN2012	RDR
		K1		REVISED PER ECO-14-002953	29JAN2014	PV DM

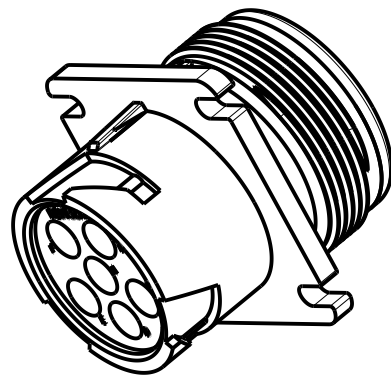

3-D VIEW

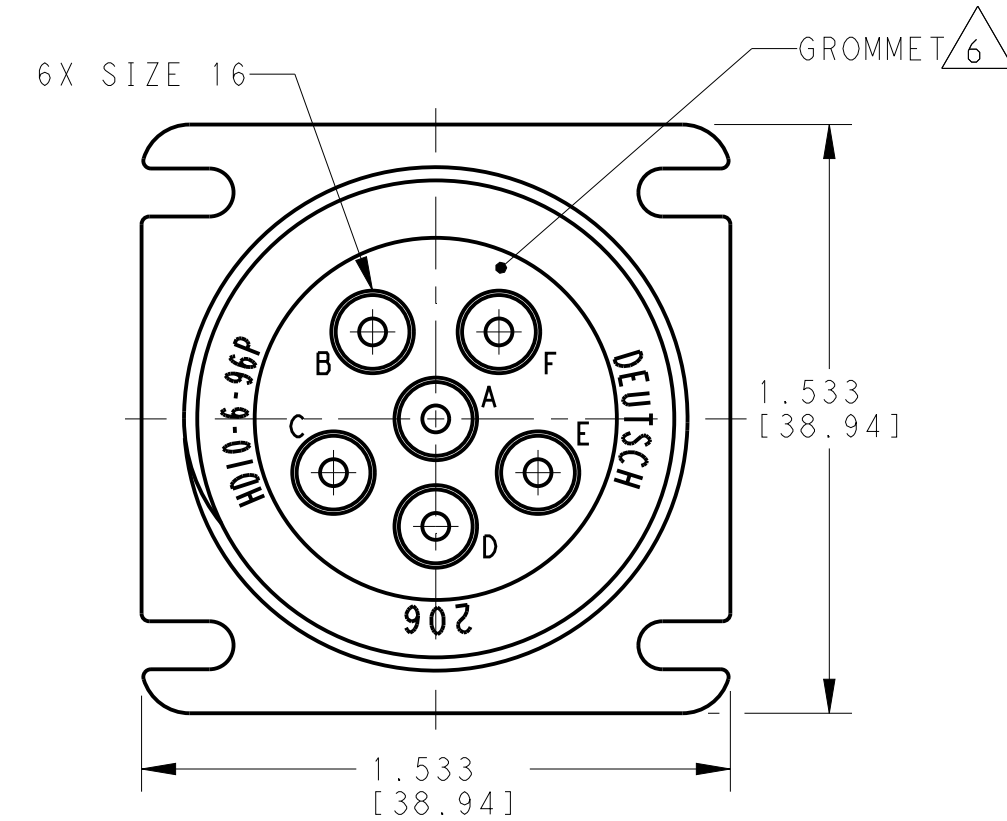
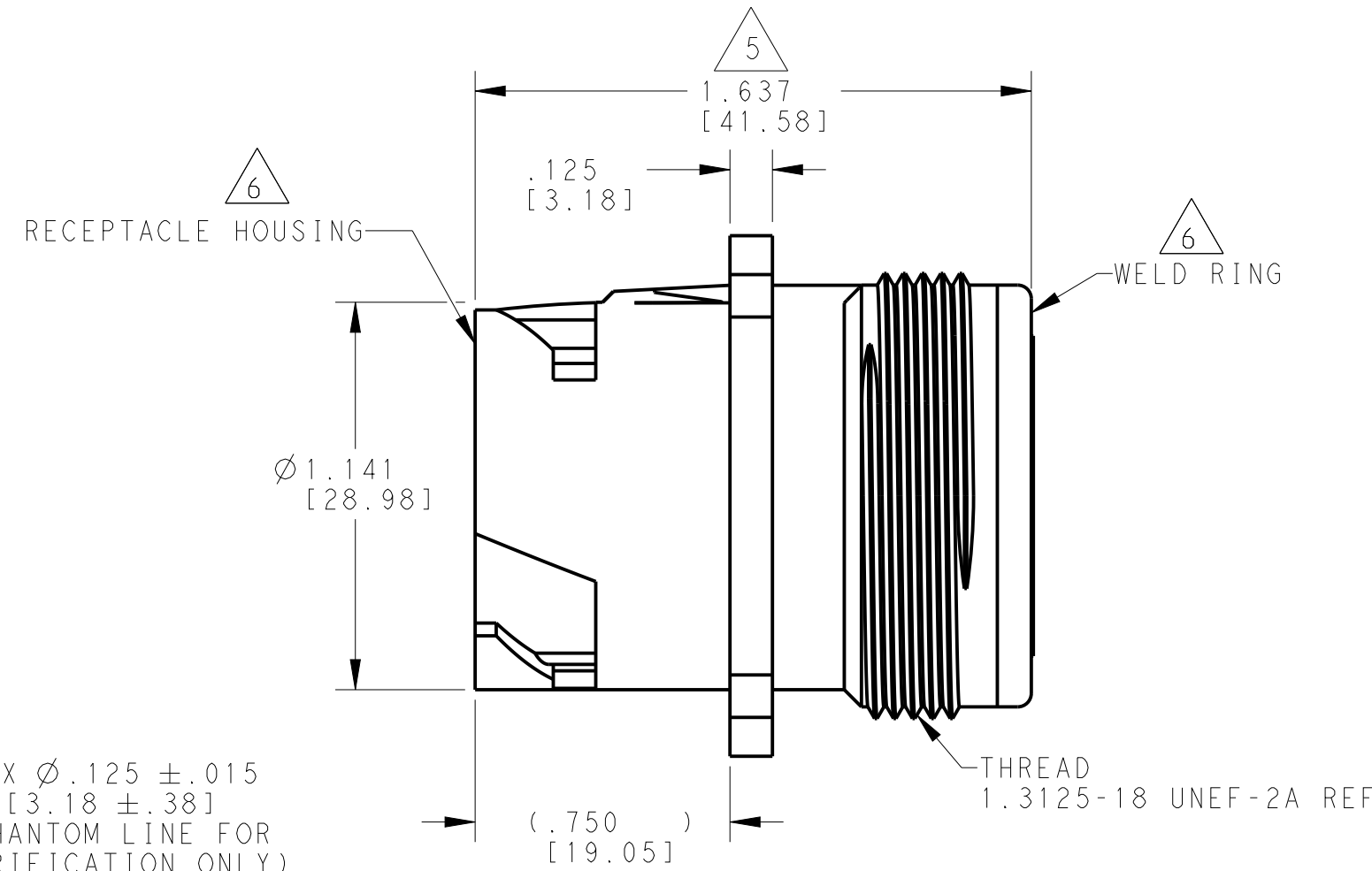
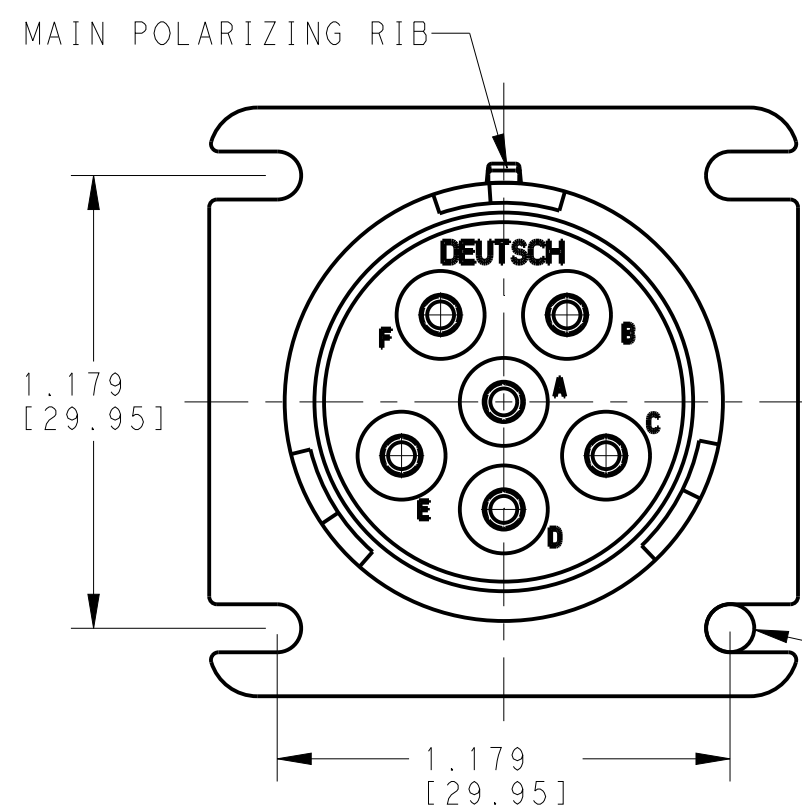

4X \varnothing .125 \pm .015 [3.18 \pm .38]
 (PHANTOM LINE FOR CLARIFICATION ONLY)

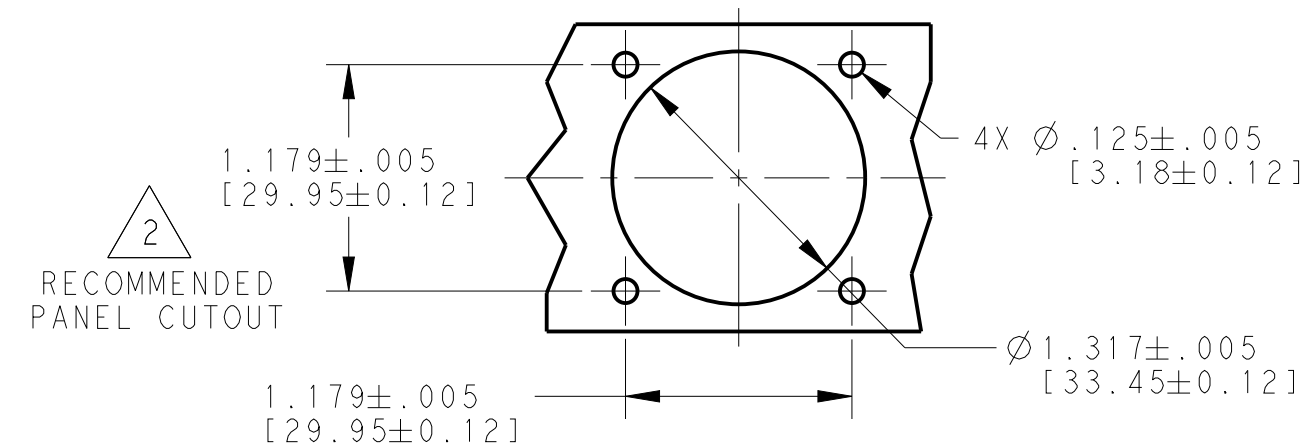

- 6. MATERIAL:
 RECEPTACLE HOUSING AND WELD RING: PA 15%GF (GREY)
 GROMMET: SILICONE (RED)
- 5. OVERALL DIMENSION DOES NOT INCLUDE RUBBER GROMMET.
- 4. THIS RECEPTACLE MATES WITH FOLLOWING PLUG (X= SEAL TYPE, XXXX= ALL MODIFICATIONS).
 HD16-6-96SX-XXXX
- 3. SEE DRAWING 0425-015-0000 FOR CONTACT AND WIRE PERFORMANCE AND APPLICATION CHARACTERISTICS.
- 2. MAXIMUM PANEL THICKNESS IS .250 [6.35].
- 1. SEE TABLE FOR USABLE WIRE RANGE AND INSULATION RANGE.

CONTACT SIZE	MINIMUM O.D.	MAXIMUM O.D.	WIRE RANGE [mm ²]
16	.100 [2.54]	.150 [3.81]	14-20 AWG [2.0-.50]

NOTES:

THIS DRAWING IS A CONTROLLED DOCUMENT.		DWN R. OCHOA 18SEP1998	STE TE Connectivity	
DIMENSIONS: INCHES [mm]		CHK I. GRANTCHAROVA 16SEP2013		
TOLERANCES UNLESS OTHERWISE SPECIFIED:		APVD D. MEYER 18SEP2013	NAME RECEPTACLE CONNECTOR SQUARE FLANGE HD10 SERIES ARR. 6-96 COLOUR: GREY	
0 PLC \pm		PRODUCT SPEC -	SIZE CAGE CODE DRAWING NO RESTRICTED TO	
1 PLC \pm		APPLICATION SPEC -	A200779 C-HD10-6-96P	
2 PLC \pm		WEIGHT 34.55 (g)	SCALE 2:1 SHEET 1 OF 1 REV K1	
3 PLC \pm .025		Customer Drawing		
4 PLC \pm				
ANGLES \pm				
FINISH \pm 0° 30' 0"				