

PART NUMBER	REV	FIRST USED	POWER UNIT	FEED TYPE	DESCRIPTION
1852796-1	A	122500-1	LEADMAKER	AIR FEED	CUTS CARRIER
1852796-2	A	565435-5	BENCH MODEL K	AIR FEED	CUTS CARRIER
1852796-3	A	354500-1	BENCH MODEL G	AIR FEED	CUTS CARRIER
7-1852796-7	A	-	-	-	SPARE PARTS

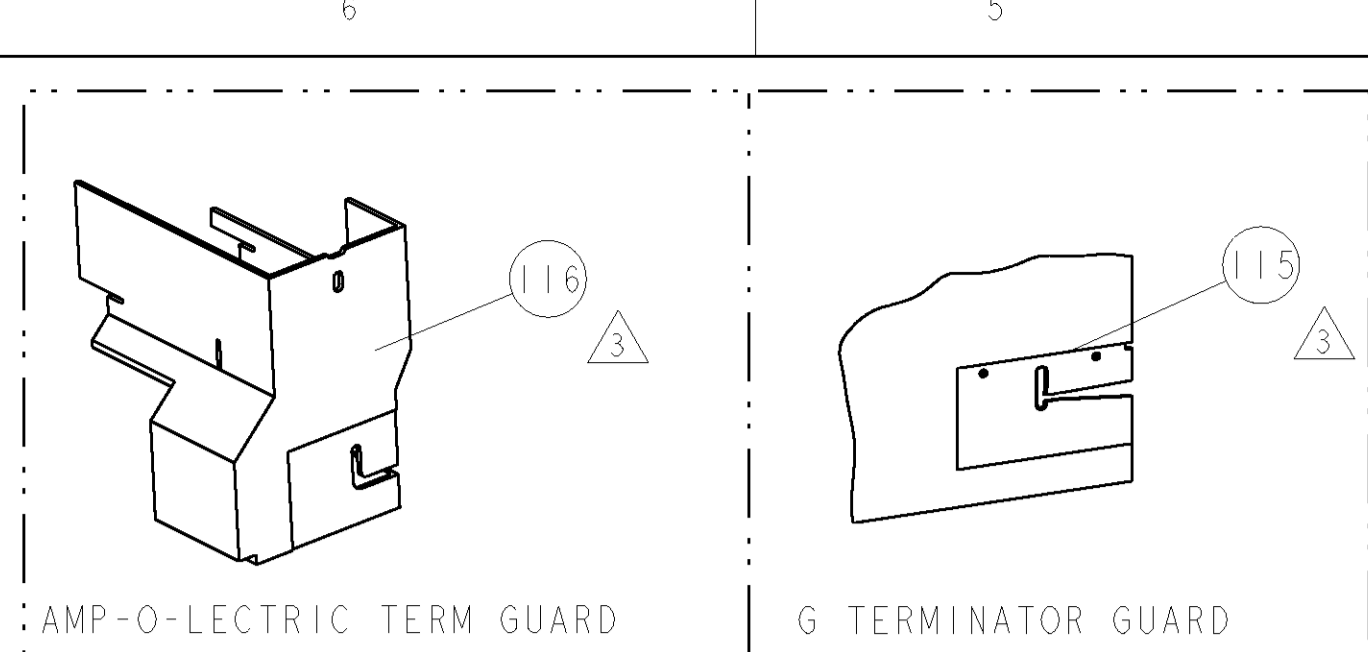

TYCO PN		MFR PN		ARKLES TERM - TE CRIMP SPECS	
1949853		4000-3G2-10			
				CRIMP HEIGHT	WIRE SIZE
				A .094±.002 [2.39±0.05mm]	14AWG
				B .086±.002 [2.18±0.05mm]	16AWG
				C .081±.002 [2.06±0.05mm]	18AWG
				D .077±.002 [1.96±0.05mm]	20AWG
				CRIMP SIZE	TYPE
				WIRE .110 [2.79mm]	F
				INSUL .170 [4.32mm]	O
				WIRE STRIP LENGTH: 145 -.160	TERM APPL SPEC NONE
				FEED .400	APPLICATOR INSTRUCTIONS 408-8040
					SET UP GAGE 458637-1

- △ RECOMMENDED SPARE PARTS
- △ GREASE LIGHTLY
- △ GUARD MUST BE IN PLACE WHEN OPERATING APPLICATOR IN A BENCH MACHINE
- △ SET ITEM 52 TO .187 FROM ITEM 50.
- △ INSTALL ITEMS 101, 102 & 119 ON SIDE OF STRIPPER ON APPLICATOR HOUSING USING ITEM 21.

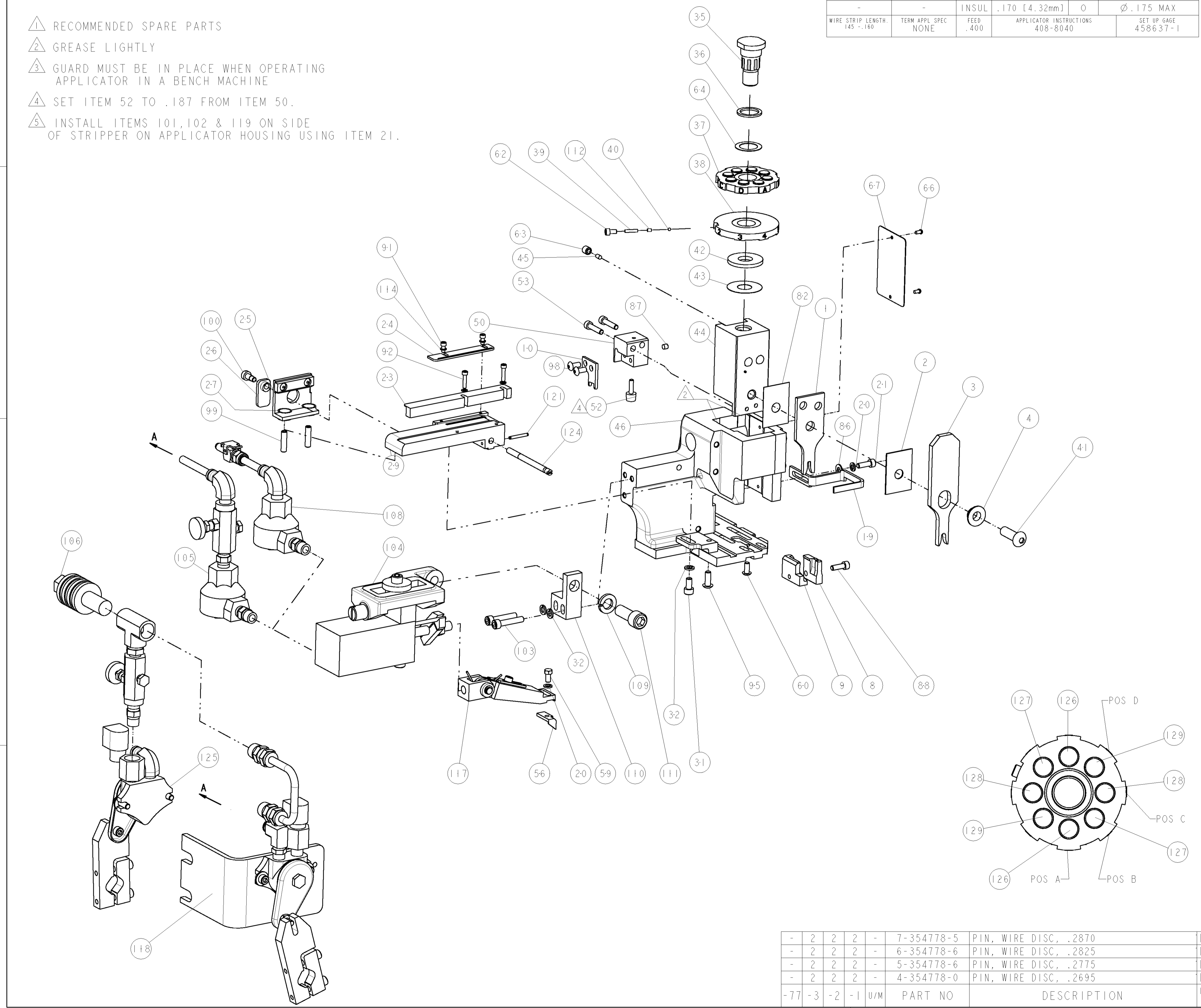

LOC	DIST	REVISIONS			
A	66	P LTR	DESCRIPTION	DATE	DWN
		A	RELEASED	13FEB2009	BH

QTY	UNIT	PART NO	DESCRIPTION	ITEM NO			
-	-	1	-	125			
-	-	1	1	124			
-	-	1	1	121			
-	18	24	18 IN	119			
-	-	1	..	118			
-	-	1	1	117			
-	-	REF	..	116			
-	-	REF	..	115			
-	4	4	4	114			
-	-	1	1	112			
-	-	1	1	111			
-	-	1	1	110			
-	-	1	1	109			
-	-	1	1	108			
-	-	1	1	106			
-	-	1	1	105			
-	-	1	1	104			
-	2	2	2	103			
-	-	1	1	102			
-	-	1	1	101			
-	-	1	1	100			
-	2	2	2	99			
-	2	2	2	98			
-	-	1	1	95			
-	2	2	2	92			
-	2	2	2	91			
-	-	1	1	88			
-	-	1	1	87			
-	-	1	1	86			
-	-	1	1	82			
-	-	1	1	72			
-	-	1	1	71			
-	-	1	1	67			
-	2	2	2	66			
-	-	1	1	64			
-	-	1	1	63			
-	-	1	1	62			
-	-	1	1	60			
-	-	1	1	59			
-	-	1	1	56			
-	2	2	2	53			
-	-	1	1	52			
-	-	1	1	50			
-	-	1	1	46			
-	-	1	1	45			
-	-	1	1	44			
-	-	1	1	43			
-	-	1	1	42			
-	-	1	1	41			
-	-	1	1	40			
-	-	1	1	39			
-	-	1	1	38			
-	-	1	1	37			
-	-	1	1	36			
-	-	1	1	35			
-	-	1	1	34			
-	-	1	1	33			
-	-	1	1	32			
-	-	1	1	31			
-	-	1	1	30			
-	-	1	1	29			
-	-	1	1	28			
-	-	1	1	27			
-	-	1	1	26			
-	-	1	1	25			
-	-	1	1	24			
-	-	1	1	23			
-	-	1	1	22			
-	-	1	1	21			
-	2	2	2	20			
-	-	1	1	19			
-	-	1	1	18			
-	-	1	1	17			
-	-	1	1	16			
-	-	1	1	15			
-	-	1	1	14			
-	-	1	1	13			
-	-	1	1	12			
-	-	1	1	11			
-	-	1	1	10			
-	-	1	1	9			
-	-	1	1	8			
-	-	1	1	7			
-	-	1	1	6			
-	-	1	1	5			
-	-	1	1	4			
-	-	1	1	3			
-	-	1	1	2			
-	-	1	1	1			
-77	-3	-2	-1	U/M	PART NO	DESCRIPTION	ITEM NO
-	2	2	2	-	7-354778-5	PIN, WIRE DISC, .2870	129
-	2	2	2	-	6-354778-6	PIN, WIRE DISC, .2825	128
-	2	2	2	-	5-354778-6	PIN, WIRE DISC, .2775	127
-	2	2	2	-	4-354778-0	PIN, WIRE DISC, .2695	126

DIMENSIONS: INCHES 		TOLERANCES UNLESS OTHERWISE SPECIFIED: 0 PLC ±.001 1 PLC ±.001 2 PLC ±.001 3 PLC ±.001 4 PLC ±.001 ANGLES ±.001		DWN: D. MORRIS 09JAN2009 CHK: D. MORRIS 09JAN2009 APVD: N. DEMING 09JAN2009 PRODUCT SPEC: SIDE FEED HDM APPLICATOR APPLICATION SPEC:		TycO Electronics Harrisburg, PA 17105-3608	
MATERIAL:		FINISH:		WEIGHT:		SCALE: 3:5 SHEET 1 OF 1 REV A	