

TOSHIBA Bi-CMOS Integrated Circuit Silicon Monolithic

# TB62747AFG, TB62747AFNG

## 16-Output Constant Current LED Driver

The TB62747 series is comprised of constant-current drivers designed for LEDs and LED panel displays.

The regulated current sources are designed to provide a constant current, which is adjustable through one external resistor.

The TB62747 series incorporates 16 channels of shift registers, latches, AND gates and constant-current outputs. Fabricated using the Bi-CMOS process, the TB62747 series satisfies the system requirement of high-speed data transmission.

It operates with a 3.3 or 5.0 V power supply.

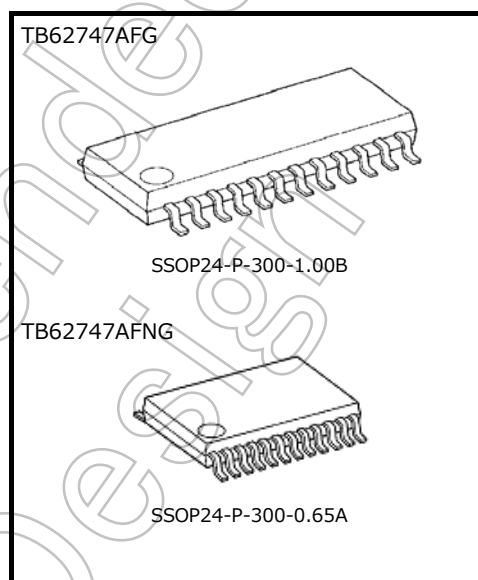

Weight

SSOP24-P-300-1.00B: 0.29 g (typ.)

SSOP24-P-300-0.65A: 0.14 g (typ.)

## Features

- 16-output built-in
- Output current setting range
  - : 1.5 to 35 mA @  $V_{DD} = 3.3\text{ V}$ ,  $V_O = 0.4$  to 1.0 V
  - : 1.5 to 45 mA @  $V_{DD} = 5.0\text{ V}$ ,  $V_O = 0.4$  to 1.2 V
- Current accuracy (@  $R_{EXT} = 1.2\text{ k}\Omega$ ,  $V_O = 0.4\text{ V}$ ,  $V_{DD} = 3.3\text{ V}, 5.0\text{ V}$ )
  - : Between outputs:  $\pm 1.5\%$  (max)
  - : Between devices:  $\pm 1.5\%$  (max)
- high-speed output switching :  $t_{wOE(L)} = 100\text{ ns}$  (min)
- Control data format : serial-in, parallel-out
- Input signal voltage level : 3.3 V and 5.0 V CMOS interfaces  
(Schmitt trigger input)
- Serial data transfer rate :  $f_{SCK} = 25\text{ MHz}$  (max) @ cascade connection
- Power supply voltages :  $V_{DD} = 3.0\text{ V}$  to 5.5 V
- Operation temperature range:  $T_{opr} = -40$  to 85 °C
- Output voltage :  $V_O = 26\text{ V}$  (max)
- Power on reset (POR)
- Package
 

: AFG type	: SSOP24-P-300-1.00B
: AFNG type	: SSOP24-P-300-0.65A

**Pin Assignment (top view)**

TB62747AFG/AFNG

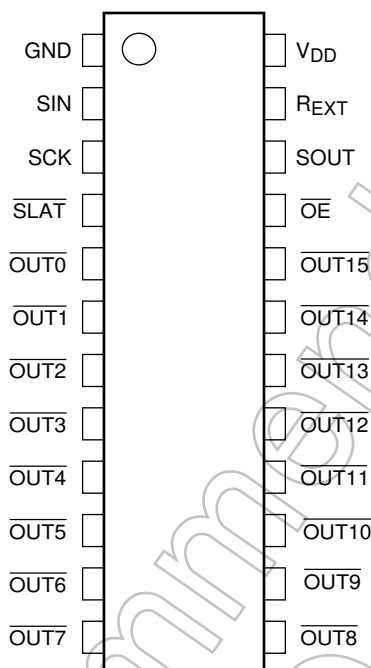

Note1: Short circuiting an output pin to a power supply pin (V<sub>DD</sub> or V<sub>LED</sub>\*), or short-circuiting the R<sub>EXT</sub> pin to the GND pin will likely exceed the rating, which in turn may result in smoldering and/or permanent damage. Please keep this in mind when determining the wiring layout for the power supply and GND pins.

\*: V<sub>LED</sub>: LED power supply

Not Recommended for New Design

**Block Diagram**

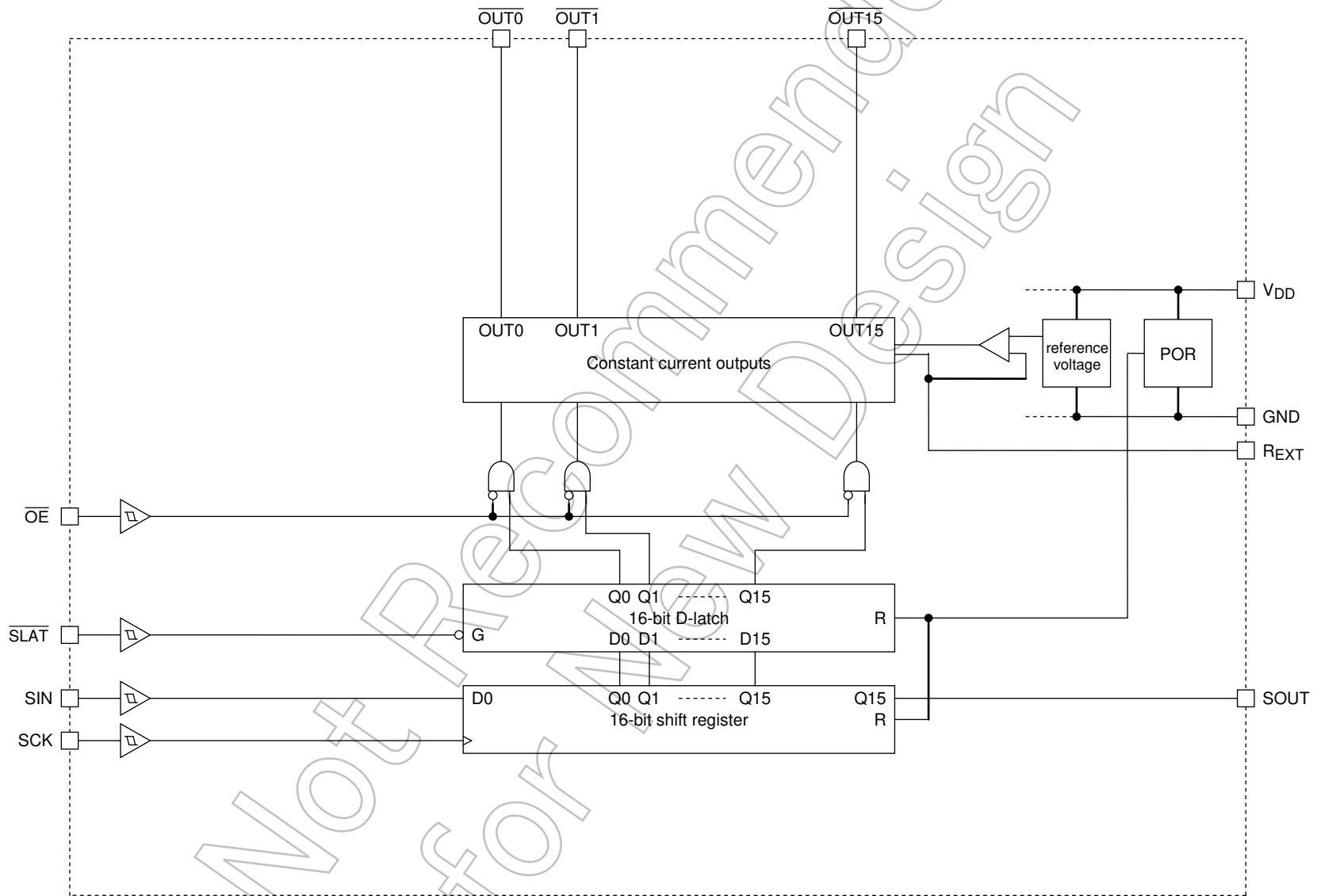

**Truth Table**

SCK	$\overline{\text{SLAT}}$	$\overline{\text{OE}}$	SIN	$\overline{\text{OUT0}}$ --- $\overline{\text{OUT7}}$ --- $\overline{\text{OUT15}}$ (Note1)	SOUT
	H	L	Dn	Dn --- Dn - 7 --- Dn - 15	Dn - 15
	L	L	Dn + 1	No Change	Dn - 14
	H	L	Dn + 2	Dn + 2 --- Dn - 5 --- Dn - 13	Dn - 13
	— (Note2)	L	Dn + 3	Dn + 2 --- Dn - 5 --- Dn - 13	Dn - 13
	— (Note2)	H	Dn + 3	OFF	Dn - 13

Note1: When  $\overline{\text{OUT0}}$  to  $\overline{\text{OUT15}}$  output pins are set to "H" the respective output will be ON and when set to "L" the respective output will be OFF.

Note2: "—" is irrelevant to the truth table.

**Timing Diagram**

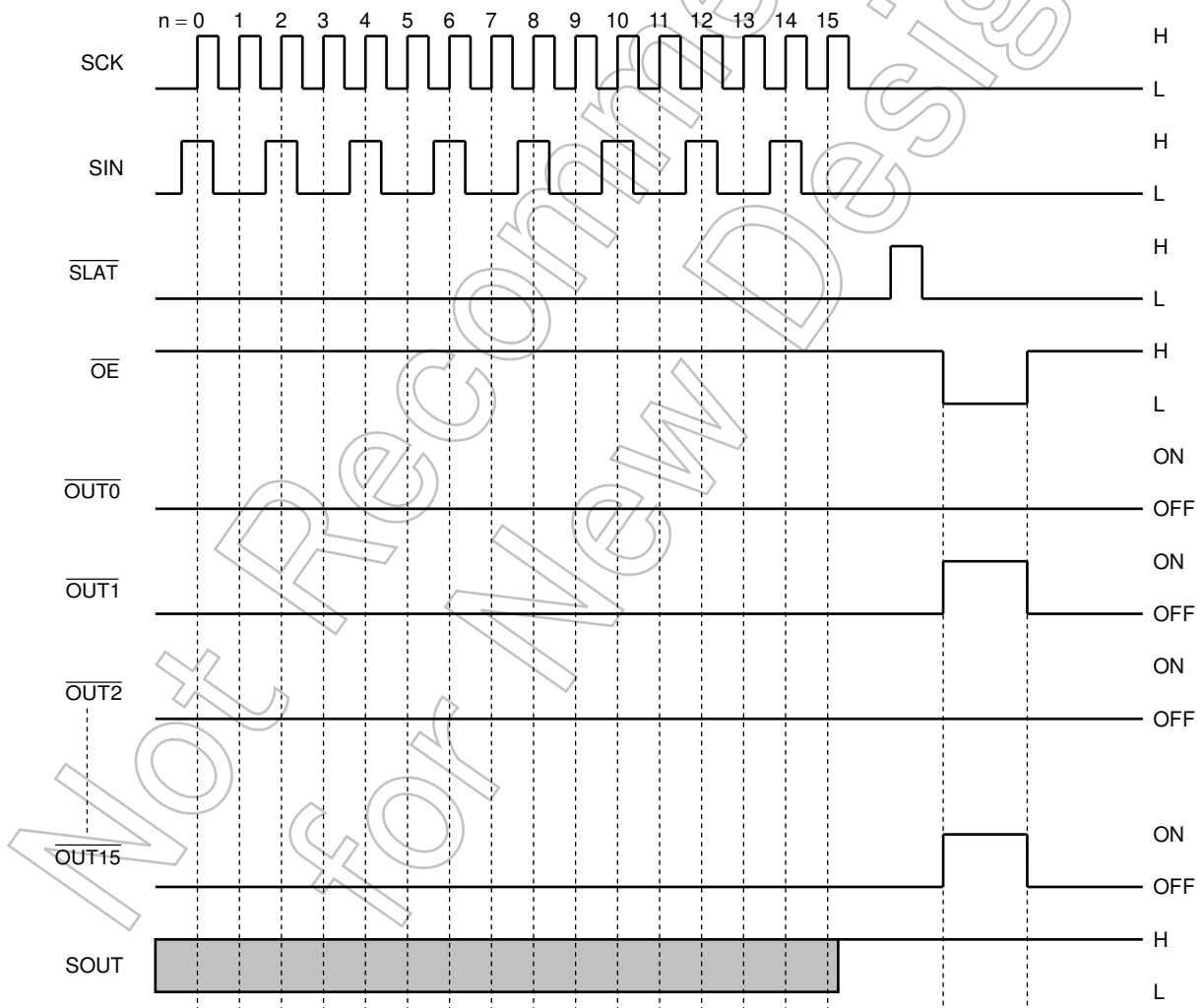

Note 1: The latch circuit is a leveled-latch circuit. Please note that it is not a triggered-latch circuit.

Note 2: Keep the  $\overline{\text{SLAT}}$  pin is set to "L" to enable the latch circuit to hold data. In addition, when the  $\overline{\text{SLAT}}$  pin is set to "H" the latch circuit does not hold data. The data will instead pass onto output. When the  $\overline{\text{OE}}$  pin is set to "L" the  $\overline{\text{OUT0}}$  to  $\overline{\text{OUT15}}$  output pins will go ON and OFF in response to the data. In addition, when the  $\overline{\text{OE}}$  pin is set to "H" all the output pins will be forced OFF regardless of the data.

## Pin Functions

Pin No	Pin Name	I/O	Function
1	GND	—	The ground pin.
2	SIN	I	The serial data input pin.
3	SCK	I	The serial data transfer clock input pin. Data are shifted at the rising edge.
4	$\overline{\text{SLAT}}$	I	The latch signal input pin. Data is saved at L level.
5	$\overline{\text{OUT0}}$	O	A sink type constant current output pin.
6	$\overline{\text{OUT1}}$	O	A sink type constant current output pin.
7	$\overline{\text{OUT2}}$	O	A sink type constant current output pin.
8	$\overline{\text{OUT3}}$	O	A sink type constant current output pin.
9	$\overline{\text{OUT4}}$	O	A sink type constant current output pin.
10	$\overline{\text{OUT5}}$	O	A sink type constant current output pin.
11	$\overline{\text{OUT6}}$	O	A sink type constant current output pin.
12	$\overline{\text{OUT7}}$	O	A sink type constant current output pin.
13	$\overline{\text{OUT8}}$	O	A sink type constant current output pin.
14	$\overline{\text{OUT9}}$	O	A sink type constant current output pin.
15	$\overline{\text{OUT10}}$	O	A sink type constant current output pin.
16	$\overline{\text{OUT11}}$	O	A sink type constant current output pin.
17	$\overline{\text{OUT12}}$	O	A sink type constant current output pin.
18	$\overline{\text{OUT13}}$	O	A sink type constant current output pin.
19	$\overline{\text{OUT14}}$	O	A sink type constant current output pin.
20	$\overline{\text{OUT15}}$	O	A sink type constant current output pin.
21	$\overline{\text{OE}}$	I	The constant current output enable signal input pin. During the "H" level, the output will be forced off.
22	SOUT	O	The serial data output pin.
23	REXT	—	The constant current value setting resistor connection pin. Then a resistor connects to the ground. All output current is set to the same.
24	VDD	—	The power supply input pin.

## Absolute Maximum Ratings (T<sub>a</sub> = 25°C)

Characteristics	Symbol	Rating (Note1)	Unit
Power supply voltage	V <sub>DD</sub>	-0.4 to 6.0	V
Output current	I <sub>O</sub>	55	mA
Logic input voltage	V <sub>IN</sub>	-0.3 to V <sub>DD</sub> + 0.3 (Note2)	V
Output voltage	V <sub>O</sub>	-0.3 to 26	V
Operating temperature	T <sub>opr</sub>	-40 to 85	°C
Storage temperature	T <sub>stg</sub>	-55 to 150	°C
Thermal resistance	Rth(j-a)	94 (AFG), 120 (AFNG) When mounted PCB (Note3)	°C/W
Power dissipation	P <sub>D</sub>	1.32 (AFG), 1.04 (AFNG) When mounted PCB (Note3), (Note4)	W

Note1: Voltage is ground referenced.

Note2: However, do not exceed 6 V.

Note3: PCB condition 76.2 mm x 114.3 mm x 1.6 mm, Cu 30 % (SEMI conforming, 4-Layer)

Note4: The power dissipation decreases the reciprocal of the saturated thermal resistance (1/ Rth(j-a)) for each One degree (°C) that the ambient temperature is exceeded from T<sub>a</sub> = 25 °C.

## Operating Conditions

### DC Items (Unless otherwise specified, V<sub>DD</sub> = 3.0 to 5.5 V, T<sub>a</sub> = -40°C to 85°C)

Characteristics	Symbol	Test Conditions	Min	Typ.	Max	Unit
Power supply voltage	V <sub>DD</sub>	—	3.0	—	5.5	V
Output voltage when ON	V <sub>O</sub> (ON)	$\overline{\text{OUTn}}$	0.4	—	4.0	V
High level logic input voltage	V <sub>IH</sub>	SIN, SCK, $\overline{\text{SLAT}}$ , OE	0.7 × V <sub>DD</sub>	—	V <sub>DD</sub>	V
Low level logic input voltage	V <sub>IL</sub>	SIN, SCK, $\overline{\text{SLAT}}$ , OE	GND	—	0.3 × V <sub>DD</sub>	V
High level SOUT output current	I <sub>OH</sub>	—	—	—	-1	mA
Low level SOUT output current	I <sub>OL</sub>	—	—	—	1	mA
Constant current output	I <sub>O1</sub>	$\overline{\text{OUTn}}$ , V <sub>DD</sub> = 3.3 V, V <sub>O</sub> = 0.4 to 1.0 V	1.5	—	35	mA
	I <sub>O2</sub>	$\overline{\text{OUTn}}$ , V <sub>DD</sub> = 5.0 V, V <sub>O</sub> = 0.4 to 1.2 V	1.5	—	45	

### AC Items (Unless otherwise specified, V<sub>DD</sub> = 3.0 to 5.5 V, T<sub>a</sub> = -40°C to 85°C)

Characteristics	Symbol	Test Circuits	Test Conditions	Min	Typ.	Max	Unit
Serial data transfer frequency	f <sub>SCK</sub>	6	—	—	—	25	MHz
Hold time	t <sub>HOLD1</sub>	6	—	5	—	—	ns
	t <sub>HOLD2</sub>	6	—	5	—	—	ns
Setup time	t <sub>SETUP1</sub>	6	—	5	—	—	ns
	t <sub>SETUP2</sub>	6	—	5	—	—	ns
Maximum clock rise time	t <sub>r</sub>	6	(Note1)	—	—	500	ns
Maximum clock fall time	t <sub>f</sub>	6	(Note1)	—	—	500	ns

Note1: If the device is connected in a cascade and the t<sub>r</sub>/t<sub>f</sub> of the clock waveform increases due to deceleration of the clock waveform, it may not be possible to achieve the timing required for data transfer. Please keep these timing conditions in mind when designing your application.

**Electrical Characteristics (Unless otherwise specified,  $V_{DD} = 3.3\text{ V}$ ,  $T_a = 25^\circ\text{C}$ )**

Characteristics	Symbol	Test Circuits	Test Conditions	Min	Typ.	Max	Unit
High level logic output voltage	$V_{OH}$	1	$I_{OH} = -1\text{ mA}$	$V_{DD} - 0.4$	—	—	V
Low level logic output voltage	$V_{OL}$	1	$I_{OL} = +1\text{ mA}$	—	—	0.4	V
High level logic input current	$I_{IH}$	2	$V_{IN} = V_{DD}, \overline{OE}, \text{SIN}, \text{SCK}$	—	—	1	$\mu\text{A}$
Low level logic input current	$I_{IL}$	3	$V_{IN} = \text{GND}, \overline{\text{SLAT}}, \text{SIN}, \text{SCK}$	—	—	-1	$\mu\text{A}$
Power supply current	$I_{DD1}$	4	$V_O = 25\text{ V}, R_{EXT} = \text{OPEN}, \text{SCK} = \text{"L"}, \overline{OE} = \text{"H"}$	—	—	1.0	mA
	$I_{DD2}$	4	$R_{EXT} = 1.2\text{ k}\Omega$ , All output off	—	—	4.0	mA
	$I_{DD3}$	4	$R_{EXT} = 1.2\text{ k}\Omega$ , All output on	—	—	8.0	mA
Output current	$I_O$	5	$V_{DD} = 3.3\text{ V}, V_O = 0.4\text{ V}, R_{EXT} = 1.2\text{ k}\Omega, \overline{\text{OUT0}} \text{ to } \overline{\text{OUT15}}$	—	14	—	mA
Constant current error(Ch to Ch)	$\Delta I_{O(\text{Ch})}$	5	$V_{DD} = 3.3\text{ V}, V_O = 0.4\text{ V}, R_{EXT} = 1.2\text{ k}\Omega, \overline{\text{OUT0}} \text{ to } \overline{\text{OUT15}}$	—	$\pm 1$	$\pm 1.5$	%
Constant current error(IC to IC)	$\Delta I_{O(\text{IC})}$	5	$V_{DD} = 3.3\text{ V}, V_O = 0.4\text{ V}, R_{EXT} = 1.2\text{ k}\Omega, \overline{\text{OUT0}} \text{ to } \overline{\text{OUT15}}$	—	$\pm 1$	$\pm 1.5$	%
Output OFF leak current	$I_{OK}$	5	$V_{DD} = 3.3\text{ V}, V_O = 25\text{ V}, R_{EXT} = 1.2\text{ k}\Omega, \overline{\text{OUT0}} \text{ to } \overline{\text{OUT15}}$	—	—	0.5	$\mu\text{A}$
Constant current power supply voltage regulation	$\%V_{DD}$	5	$V_{DD} = 3.0 \text{ to } 3.6\text{ V}, V_O = 0.4\text{ V}, R_{EXT} = 1.2\text{ k}\Omega, \overline{\text{OUT0}} \text{ to } \overline{\text{OUT15}}$	—	$\pm 1$	$\pm 2$	%
Constant current output voltage regulation	$\%V_O$	5	$V_{DD} = 3.3\text{ V}, V_O = 0.4 \text{ to } 3.0\text{ V}, R_{EXT} = 1.2\text{ k}\Omega, \overline{\text{OUT0}} \text{ to } \overline{\text{OUT15}}$	—	$\pm 1$	—	%/V
Pull-up resistor	$R_{UP}$	3	$\overline{OE}$	250	500	800	$\text{k}\Omega$
Pull-down resistor	$R_{DOWN}$	2	$\overline{\text{SLAT}}$	250	500	800	$\text{k}\Omega$

Not Recommended for New

**Electrical Characteristics (Unless otherwise specified,  $V_{DD} = 5.0\text{ V}$ ,  $T_a = 25^\circ\text{C}$ )**

Characteristics	Symbol	Test Circuits	Test Conditions	Min	Typ.	Max	Unit
High level logic output voltage	$V_{OH}$	1	$I_{OH} = -1\text{ mA}$	$V_{DD} - 0.4$	—	—	V
Low level logic output voltage	$V_{OL}$	1	$I_{OL} = +1\text{ mA}$	—	—	0.4	V
High level logic input current	$I_{IH}$	2	$V_{IN} = V_{DD}, \overline{OE}, \text{SIN}, \text{SCK}$	—	—	1	$\mu\text{A}$
Low level logic input current	$I_{IL}$	3	$V_{IN} = \text{GND}, \overline{\text{SLAT}}, \text{SIN}, \text{SCK}$	—	—	-1	$\mu\text{A}$
Power supply current	$I_{DD1}$	4	$V_O = 25\text{ V}, R_{EXT} = \text{OPEN}, \text{SCK} = \text{"L"}, \overline{OE} = \text{"H"}$	—	—	1.0	mA
	$I_{DD2}$	4	$R_{EXT} = 1.2\text{ k}\Omega$ , All output off	—	—	4.5	mA
	$I_{DD3}$	4	$R_{EXT} = 1.2\text{ k}\Omega$ , All output on	—	—	8.0	mA
Output current	$I_O$	5	$V_{DD} = 5.0\text{ V}, V_O = 0.4\text{ V}, R_{EXT} = 1.2\text{ k}\Omega, \overline{\text{OUT0}} \text{ to } \overline{\text{OUT15}}$	—	14	—	mA
Constant current error(Ch to Ch)	$\Delta I_{O(\text{Ch})}$	5	$V_{DD} = 5.0\text{ V}, V_O = 0.4\text{ V}, R_{EXT} = 1.2\text{ k}\Omega, \overline{\text{OUT0}} \text{ to } \overline{\text{OUT15}}$	—	$\pm 1$	$\pm 1.5$	%
Constant current error(IC to IC)	$\Delta I_{O(\text{IC})}$	5	$V_{DD} = 5.0\text{ V}, V_O = 0.4\text{ V}, R_{EXT} = 1.2\text{ k}\Omega, \overline{\text{OUT0}} \text{ to } \overline{\text{OUT15}}$	—	$\pm 1$	$\pm 1.5$	%
Output OFF leak current	$I_{OK}$	5	$V_{DD} = 5.0\text{ V}, V_O = 25\text{ V}, R_{EXT} = 1.2\text{ k}\Omega, \overline{\text{OUT0}} \text{ to } \overline{\text{OUT15}}$	—	—	0.5	$\mu\text{A}$
Constant current power supply voltage regulation	$\%V_{DD}$	5	$V_{DD} = 4.5 \text{ to } 5.5\text{ V}, V_O = 0.4\text{ V}, R_{EXT} = 1.2\text{ k}\Omega, \overline{\text{OUT0}} \text{ to } \overline{\text{OUT15}}$	—	$\pm 1$	$\pm 2$	%
Constant current output voltage regulation	$\%V_O$	5	$V_{DD} = 5.0\text{ V}, V_O = 0.4 \text{ to } 3.0\text{ V}, R_{EXT} = 1.2\text{ k}\Omega, \overline{\text{OUT0}} \text{ to } \overline{\text{OUT15}}$	—	$\pm 1$	—	$\%/V$
Pull-up resistor	$R_{UP}$	3	$\overline{OE}$	250	500	800	$\text{k}\Omega$
Pull-down resistor	$R_{DOWN}$	2	$\overline{\text{SLAT}}$	250	500	800	$\text{k}\Omega$

Not Recommended for New



**Switching Characteristics (Unless otherwise specified,  $V_{DD} = 3.0\text{ V}$ ,  $T_a = 25^\circ\text{C}$ )**

Characteristics		Symbol	Test Circuits	Test Conditions	Min	Typ.	Max	Unit
Propagation delay time	SCK- $\overline{\text{OUT0}}$	$t_{pLH1}$	6	$\overline{\text{SLAT}} = \text{"H"}, \overline{\text{OE}} = \text{"L"}$	—	20	300	ns
	$\overline{\text{SLAT}} - \overline{\text{OUT0}}$	$t_{pLH2}$	6	$\overline{\text{OE}} = \text{"L"}$	—	20	300	ns
	$\overline{\text{OE}} - \overline{\text{OUT0}}$	$t_{pLH3}$	6	$\overline{\text{SLAT}} = \text{"H"}$	—	20	300	ns
	SCK-SOUT	$t_{pLH}$	6	CL=10.5 pF	10	20	35	ns
	SCK- $\overline{\text{OUT0}}$	$t_{pHL1}$	6	$\overline{\text{SLAT}} = \text{"H"}, \overline{\text{OE}} = \text{"L"}$	—	30	340	ns
	$\overline{\text{SLAT}} - \overline{\text{OUT0}}$	$t_{pHL2}$	6	$\overline{\text{OE}} = \text{"L"}$	—	70	340	ns
	$\overline{\text{OE}} - \overline{\text{OUT0}}$	$t_{pHL3}$	6	$\overline{\text{SLAT}} = \text{"H"}$	—	70	340	ns
	SCK-SOUT	$t_{pHL}$	6	CL=10.5 pF	10	20	35	ns
Output rise time	$t_{or}$	6	10 to 90 % of voltage waveform	—	20	90	ns	
Output fall time	$t_{of}$	6	90 to 10 % of voltage waveform	—	25	180	ns	
Enable pulse width	$t_{wOE(L)}$	6	$\overline{\text{OE}} = \text{"L"}$ (Note1)	100	—	—	ns	
Clock pulse width	$t_{wSCK}$	6	SCK = "H" or "L"	20	—	—	ns	
Latch pulse width	$t_{wSLAT}$	6	$\overline{\text{SLAT}} = \text{"H"}$	20	—	—	ns	

Note1: At the condition of  $t_{wOE(H)} = 250\text{ ns}$  or more

**Switching Characteristics (Unless otherwise specified,  $V_{DD} = 5.5\text{ V}$ ,  $T_a = 25^\circ\text{C}$ )**

Characteristics		Symbol	Test Circuits	Test Conditions	Min	Typ.	Max	Unit
Propagation delay time	SCK- $\overline{\text{OUT0}}$	$t_{pLH1}$	6	$\overline{\text{SLAT}} = \text{"H"}, \overline{\text{OE}} = \text{"L"}$	—	20	300	ns
	$\overline{\text{SLAT}} - \overline{\text{OUT0}}$	$t_{pLH2}$	6	$\overline{\text{OE}} = \text{"L"}$	—	20	300	ns
	$\overline{\text{OE}} - \overline{\text{OUT0}}$	$t_{pLH3}$	6	$\overline{\text{SLAT}} = \text{"H"}$	—	20	300	ns
	SCK-SOUT	$t_{pLH}$	6	CL=10.5 pF	10	20	35	ns
	SCK- $\overline{\text{OUT0}}$	$t_{pHL1}$	6	$\overline{\text{SLAT}} = \text{"H"}, \overline{\text{OE}} = \text{"L"}$	—	30	340	ns
	$\overline{\text{SLAT}} - \overline{\text{OUT0}}$	$t_{pHL2}$	6	$\overline{\text{OE}} = \text{"L"}$	—	70	340	ns
	$\overline{\text{OE}} - \overline{\text{OUT0}}$	$t_{pHL3}$	6	$\overline{\text{SLAT}} = \text{"H"}$	—	70	340	ns
	SCK-SOUT	$t_{pHL}$	6	CL=10.5 pF	10	20	35	ns
Output rise time	$t_{or}$	6	10 to 90 % of voltage waveform	—	20	90	ns	
Output fall time	$t_{of}$	6	90 to 10 % of voltage waveform	—	25	180	ns	
Enable pulse width	$t_{wOE(L)}$	6	$\overline{\text{OE}} = \text{"L"}$ (Note1)	100	—	—	ns	
Clock pulse width	$t_{wSCK}$	6	SCK = "H" or "L"	20	—	—	ns	
Latch pulse width	$t_{wSLAT}$	6	$\overline{\text{SLAT}} = \text{"H"}$	20	—	—	ns	

Note1: At the condition of  $t_{wOE(H)} = 250\text{ ns}$  or more

**I/O Equivalent Circuits**

**1. SCK, SIN**

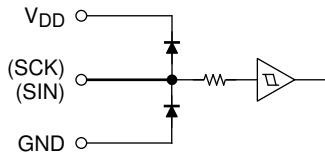

**2.  $\overline{OE}$**

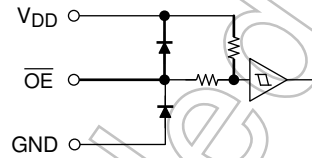

**3.  $\overline{SLAT}$**

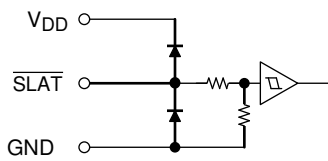

**4. SOUT**

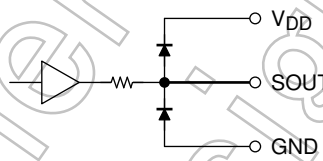

**5.  $\overline{OUT0}$  to  $\overline{OUT15}$**

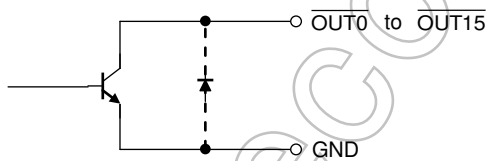

Not Recommended for New Design

**Test Circuits**

Test Circuit1: High level logic output voltage / Low level logic output voltage

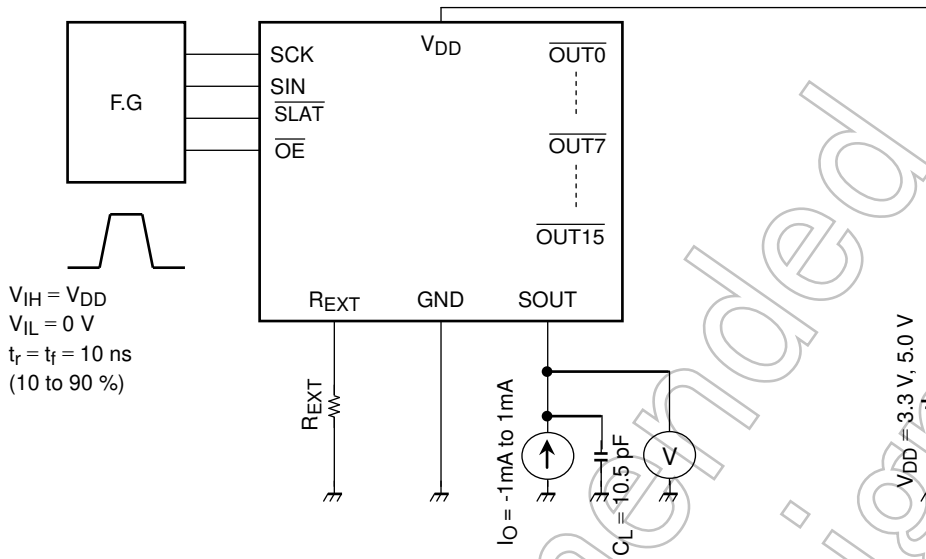

Test Circuit2: High level logic input current / Pull-down resistor

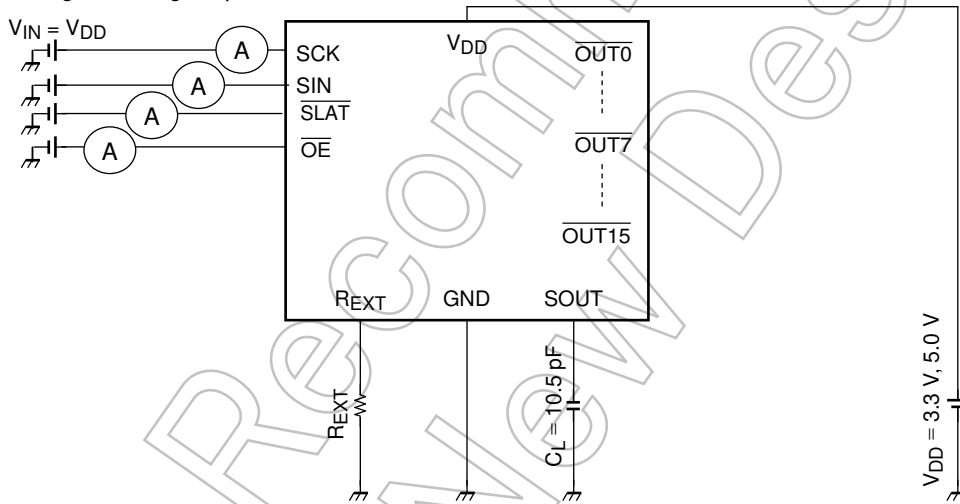

Test Circuit3: Low level logic input current / Pull-up resistor

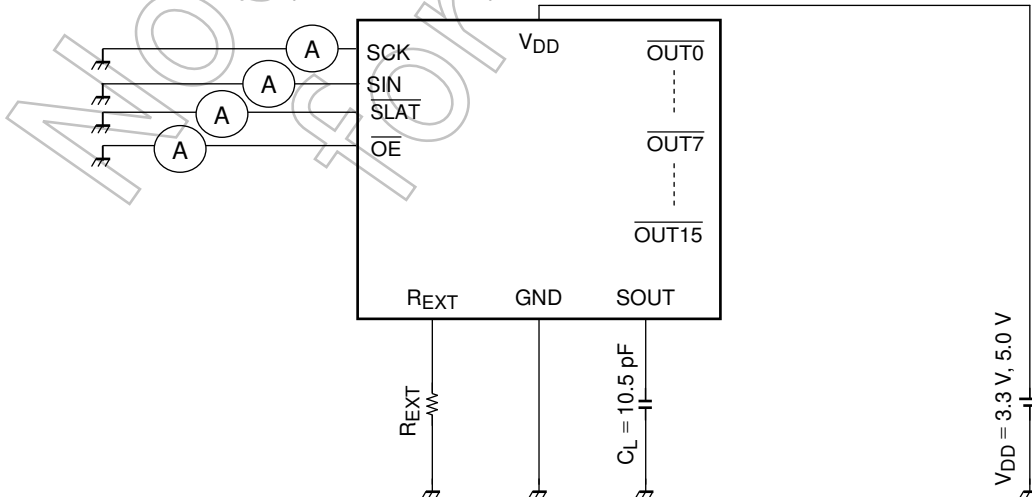

Test Circuit4: Power supply current

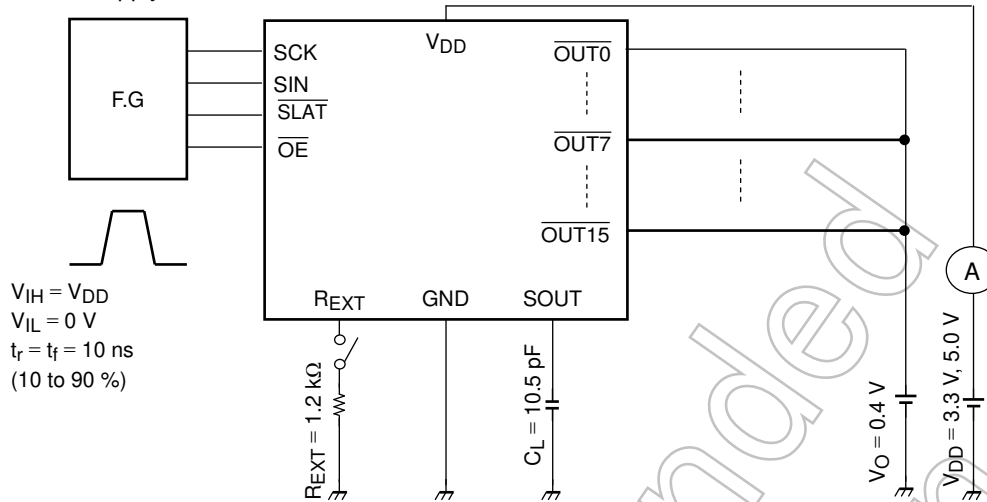

Test Circuit5: Constant current output / Output OFF leak current / Constant current error  
Constant current power supply voltage regulation / Constant current output voltage regulation

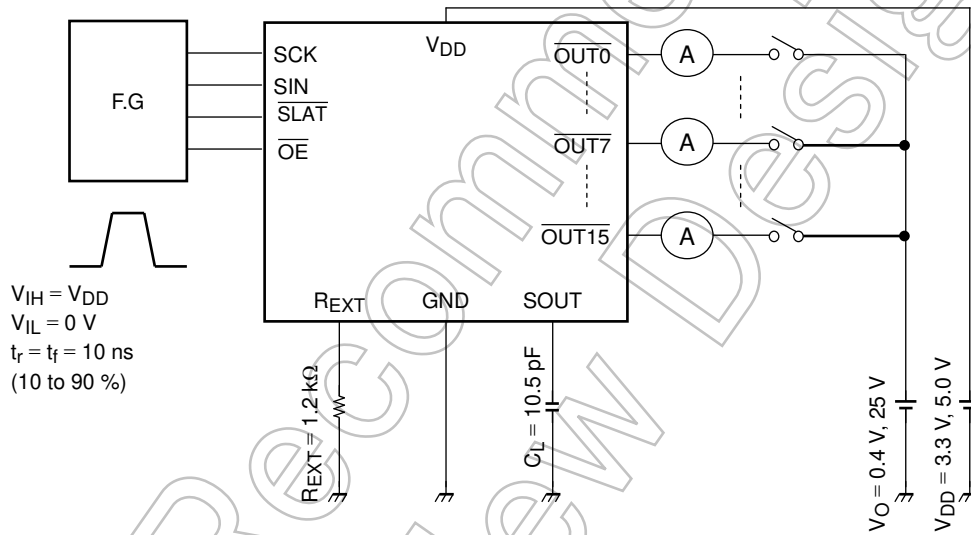

Test Circuit6: Switching Characteristics

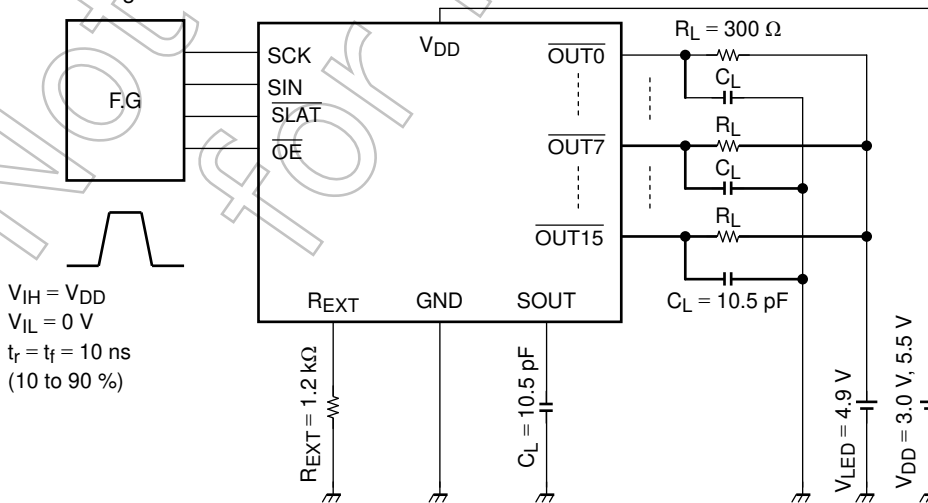

**Timing Waveforms**

**1. SCK, SIN, SOUT**

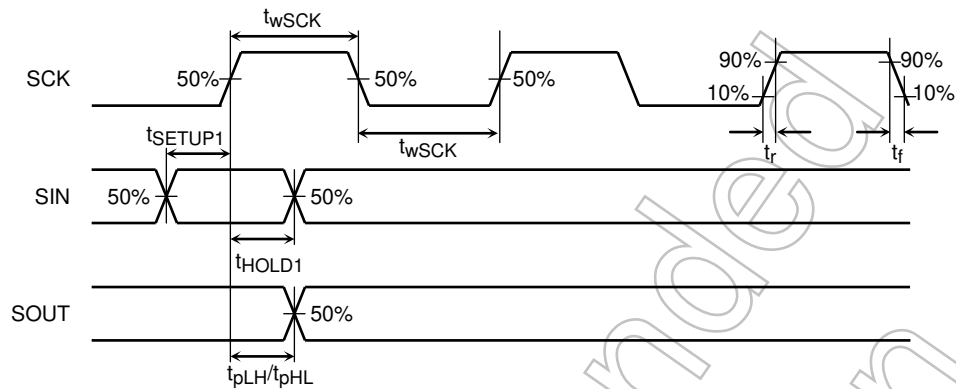

**2. SCK, SIN, SLAT, OE, OUT0**

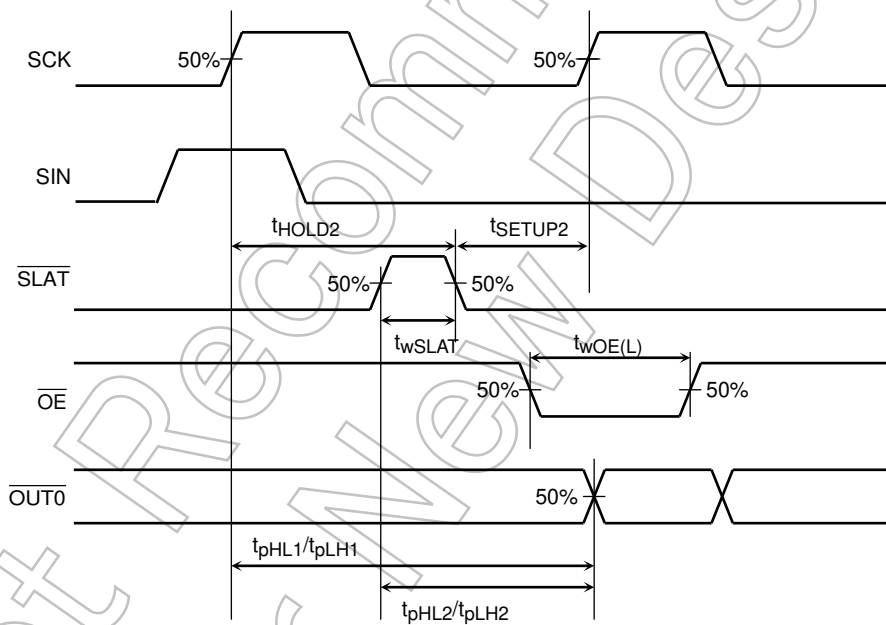

**3. OE, OUT0**

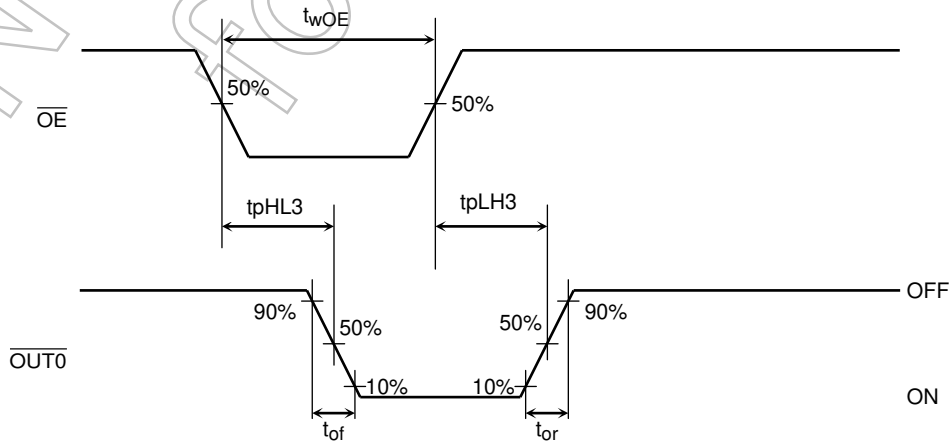

**Reference data**

\*This data is provided for reference only. Thorough evaluation and testing should be implemented when designing your application's mass production design.

**Output Current – R<sub>EXT</sub> Resistor**

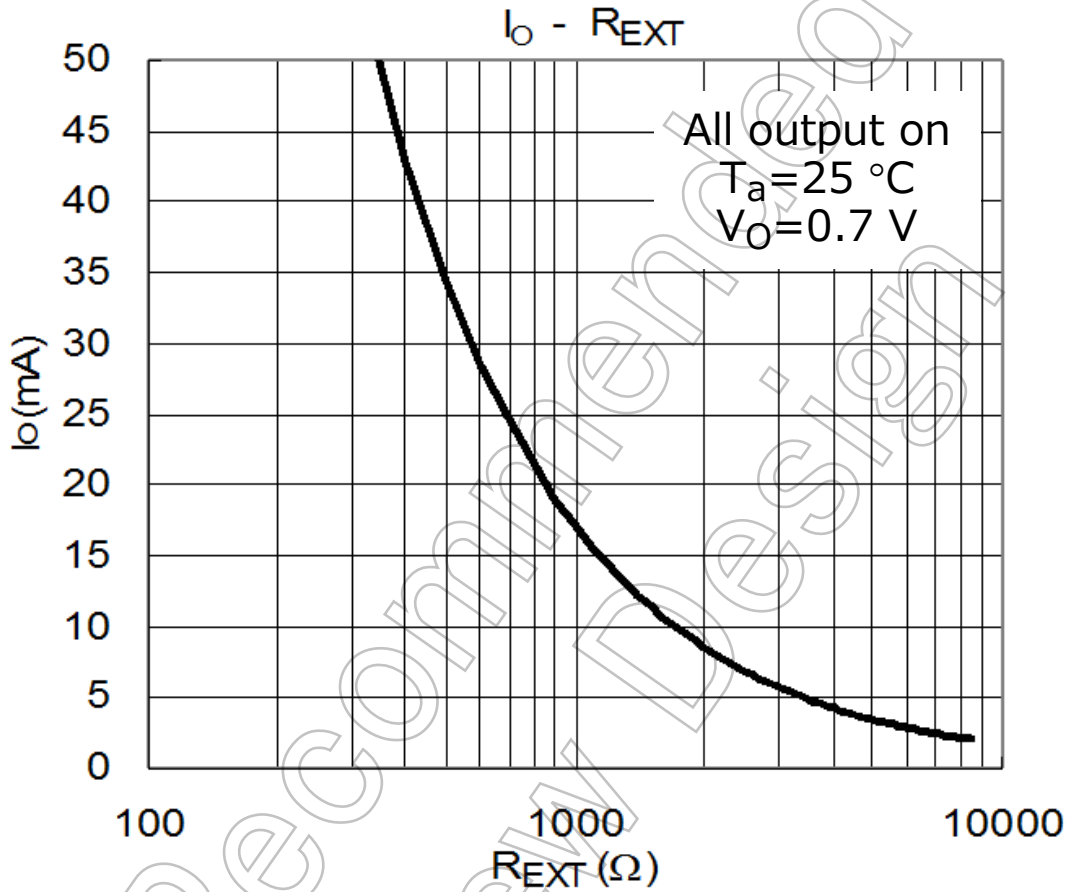

**Theoretical value**

$$I_{OUT(A)} = 1.13 (V) \div R_{EXT} (\Omega) \times 14.9$$

Not Recommended for New Designs

**Reference data**

\*This data is provided for reference only. Thorough evaluation and testing should be implemented when designing your application's mass production design.

**Output Current – Duty (LED turn-on rate)**

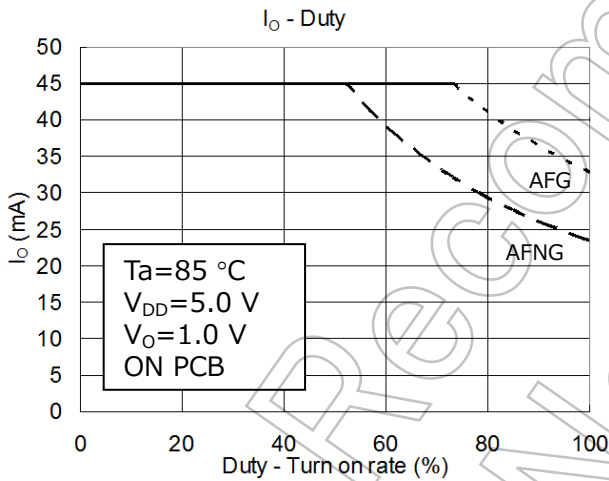
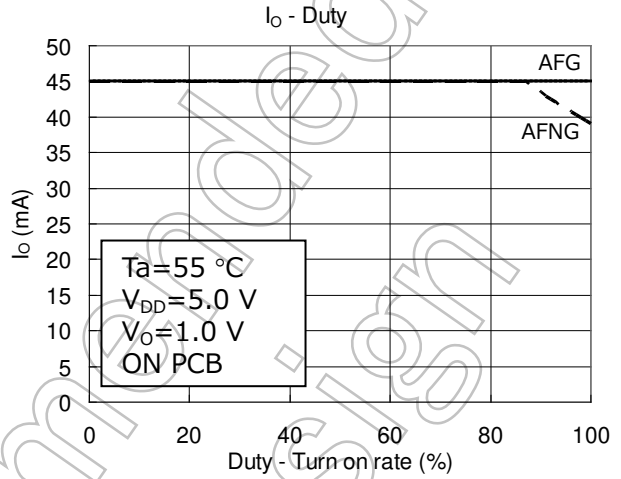
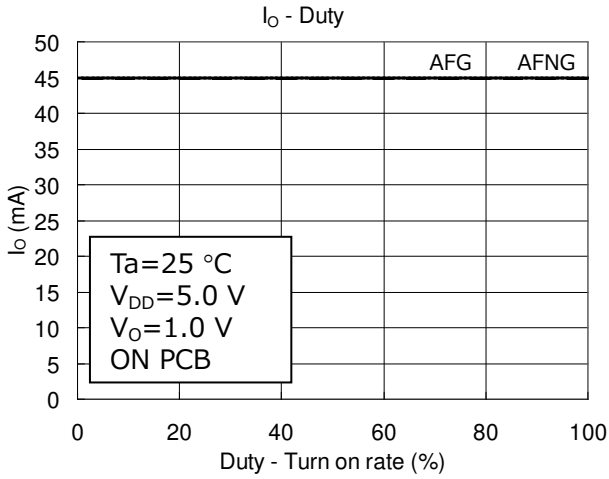

**Power dissipation – Ta**

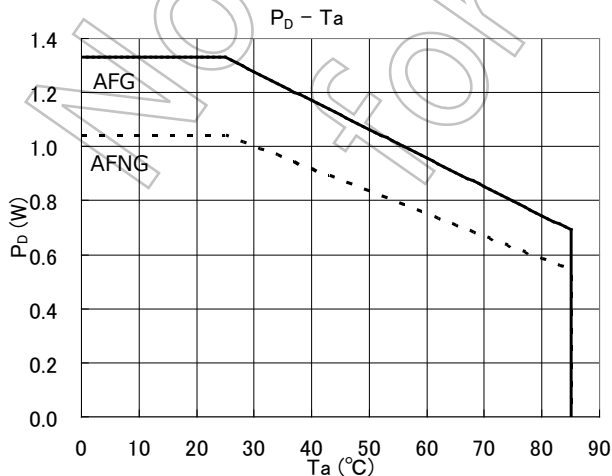

Package Dimensions

SSOP24-P-300-1.00B

Unit : mm

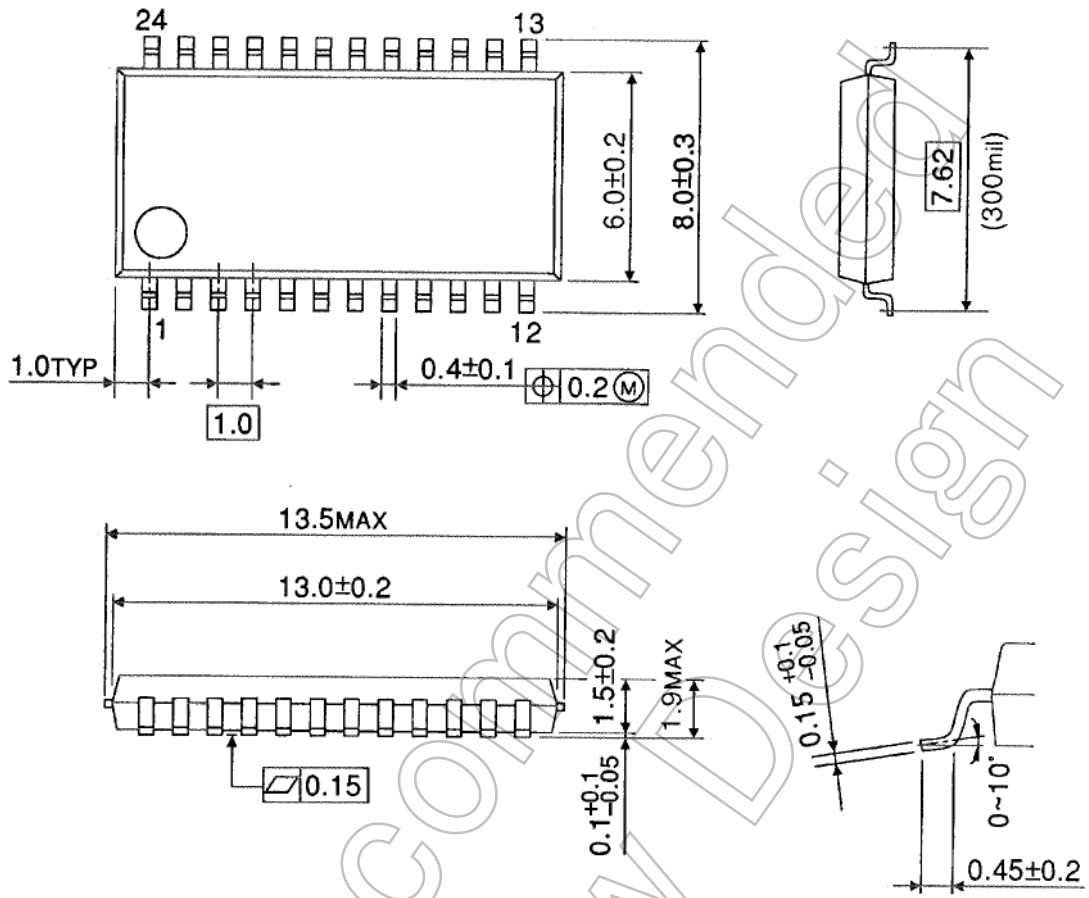

Weight: 0.29 g (typ.)

Not Recommended for New Design



Package Dimensions

SSOP24-P-300-0.65A

Unit : mm

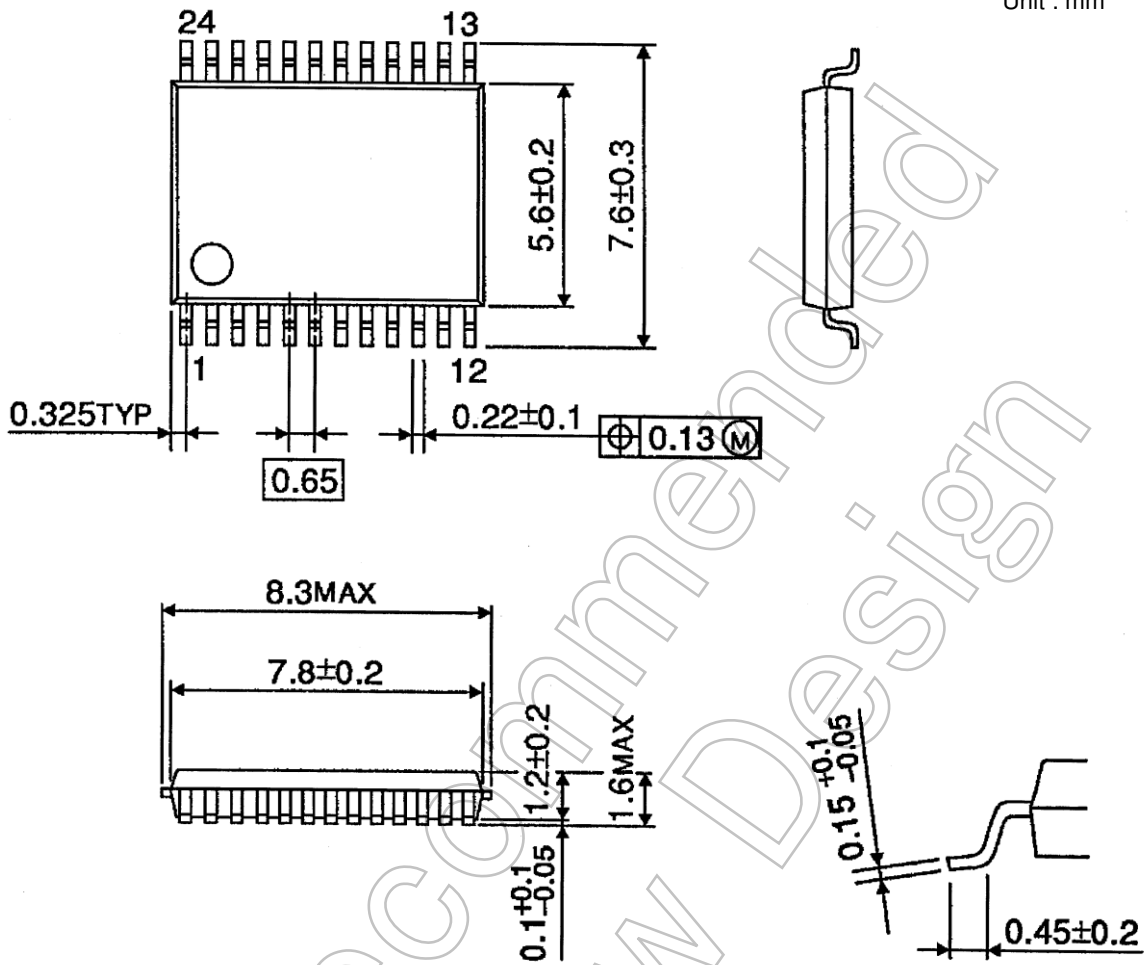

Weight: 0.14 g (typ.)

Not Recommended for New Design

## Notes on Contents

### 1. Block Diagrams

Some of the functional blocks, circuits, or constants in the block diagram may be omitted or simplified for explanatory purposes.

### 2. Equivalent Circuits

The equivalent circuit diagrams may be simplified or some parts of them may be omitted for explanatory purposes.

### 3. Timing Charts

Timing charts may be simplified for explanatory purposes.

### 4. Application Circuits

The application circuits shown in this document are provided for reference purposes only. Thorough evaluation is required, especially at the mass production design stage.

Toshiba does not grant any license to any industrial property rights by providing these examples of application circuits.

### 5. Test Circuits

Components in the test circuits are used only to obtain and confirm the device characteristics. These components and circuits are not guaranteed to prevent malfunction or failure from occurring in the application equipment.

## IC Usage Considerations

### Notes on handling of ICs

[1] The absolute maximum ratings of a semiconductor device are a set of ratings that must not be exceeded, even for a moment. Do not exceed any of these ratings. Exceeding the rating(s) may cause the device breakdown, damage or deterioration, and may result injury by explosion or combustion.

[2] Use an appropriate power supply fuse to ensure that a large current does not continuously flow in case of over current and/or IC failure. The IC will fully break down when used under conditions that exceed its absolute maximum ratings, when the wiring is routed improperly or when an abnormal pulse noise occurs from the wiring or load, causing a large current to continuously flow and the breakdown can lead smoke or ignition. To minimize the effects of the flow of a large current in case of breakdown, appropriate settings, such as fuse capacity, fusing time and insertion circuit location, are required.

[3] If your design includes an inductive load such as a motor coil, incorporate a protection circuit into the design to prevent device malfunction or breakdown caused by the current resulting from the inrush current at power ON or the negative current resulting from the back electromotive force at power OFF. IC breakdown may cause injury, smoke or ignition.

Use a stable power supply with ICs with built-in protection functions. If the power supply is unstable, the protection function may not operate, causing IC breakdown. IC breakdown may cause injury, smoke or ignition.

[4] Do not insert devices in the wrong orientation or incorrectly.

Make sure that the positive and negative terminals of power supplies are connected properly.

Otherwise, the current or power consumption may exceed the absolute maximum rating, and exceeding the rating(s) may cause the device breakdown, damage or deterioration, and may result injury by explosion or combustion.

In addition, do not use any device that is applied the current with inserting in the wrong orientation or incorrectly even just one time.

[5] Carefully select external components (such as inputs and negative feedback capacitors) and load components (such as speakers), for example, power amp and regulator.

If there is a large amount of leakage current such as input or negative feedback condenser, the IC output DC voltage will increase. If this output voltage is connected to a speaker with low input withstand voltage, overcurrent or IC failure can cause smoke or ignition. (The over current can cause smoke or ignition from the IC itself.) In particular, please pay attention when using a Bridge Tied Load (BTL) connection type IC that inputs output DC voltage to a speaker directly.

**Points to remember on handling of ICs****(1) Heat Radiation Design**

In using an IC with large current flow such as power amp, regulator or driver, please design the device so that heat is appropriately radiated, not to exceed the specified junction temperature ( $T_j$ ) at any time and condition. These ICs generate heat even during normal use. An inadequate IC heat radiation design can lead to decrease in IC life, deterioration of IC characteristics or IC breakdown. In addition, please design the device taking into consideration the effect of IC heat radiation with peripheral components.

**(2) Back-EMF**

When a motor rotates in the reverse direction, stops or slows down abruptly, a current flow back to the motor's power supply due to the effect of back-EMF. If the current sink capability of the power supply is small, the device's motor power supply and output pins might be exposed to conditions beyond maximum ratings. To avoid this problem, take the effect of back-EMF into consideration in system design.

Not Recommended  
for New Design

**RESTRICTIONS ON PRODUCT USE**

- Toshiba Corporation, and its subsidiaries and affiliates (collectively "TOSHIBA"), reserve the right to make changes to the information in this document, and related hardware, software and systems (collectively "Product") without notice.
- This document and any information herein may not be reproduced without prior written permission from TOSHIBA. Even with TOSHIBA's written permission, reproduction is permissible only if reproduction is without alteration/omission.
- Though TOSHIBA works continually to improve Product's quality and reliability, Product can malfunction or fail. Customers are responsible for complying with safety standards and for providing adequate designs and safeguards for their hardware, software and systems which minimize risk and avoid situations in which a malfunction or failure of Product could cause loss of human life, bodily injury or damage to property, including data loss or corruption. Before customers use the Product, create designs including the Product, or incorporate the Product into their own applications, customers must also refer to and comply with (a) the latest versions of all relevant TOSHIBA information, including without limitation, this document, the specifications, the data sheets and application notes for Product and the precautions and conditions set forth in the "TOSHIBA Semiconductor Reliability Handbook" and (b) the instructions for the application with which the Product will be used with or for. Customers are solely responsible for all aspects of their own product design or applications, including but not limited to (a) determining the appropriateness of the use of this Product in such design or applications; (b) evaluating and determining the applicability of any information contained in this document, or in charts, diagrams, programs, algorithms, sample application circuits, or any other referenced documents; and (c) validating all operating parameters for such designs and applications. **TOSHIBA ASSUMES NO LIABILITY FOR CUSTOMERS' PRODUCT DESIGN OR APPLICATIONS.**
- **PRODUCT IS NEITHER INTENDED NOR WARRANTED FOR USE IN EQUIPMENTS OR SYSTEMS THAT REQUIRE EXTRAORDINARILY HIGH LEVELS OF QUALITY AND/OR RELIABILITY, AND/OR A MALFUNCTION OR FAILURE OF WHICH MAY CAUSE LOSS OF HUMAN LIFE, BODILY INJURY, SERIOUS PROPERTY DAMAGE AND/OR SERIOUS PUBLIC IMPACT ("UNINTENDED USE").** Except for specific applications as expressly stated in this document, Unintended Use includes, without limitation, equipment used in nuclear facilities, equipment used in the aerospace industry, medical equipment, equipment used for automobiles, trains, ships and other transportation, traffic signaling equipment, equipment used to control combustions or explosions, safety devices, elevators and escalators, devices related to electric power, and equipment used in finance-related fields. **IF YOU USE PRODUCT FOR UNINTENDED USE, TOSHIBA ASSUMES NO LIABILITY FOR PRODUCT.** For details, please contact your TOSHIBA sales representative.
- Do not disassemble, analyze, reverse-engineer, alter, modify, translate or copy Product, whether in whole or in part.
- Product shall not be used for or incorporated into any products or systems whose manufacture, use, or sale is prohibited under any applicable laws or regulations.
- The information contained herein is presented only as guidance for Product use. No responsibility is assumed by TOSHIBA for any infringement of patents or any other intellectual property rights of third parties that may result from the use of Product. No license to any intellectual property right is granted by this document, whether express or implied, by estoppel or otherwise.
- **ABSENT A WRITTEN SIGNED AGREEMENT, EXCEPT AS PROVIDED IN THE RELEVANT TERMS AND CONDITIONS OF SALE FOR PRODUCT, AND TO THE MAXIMUM EXTENT ALLOWABLE BY LAW, TOSHIBA (1) ASSUMES NO LIABILITY WHATSOEVER, INCLUDING WITHOUT LIMITATION, INDIRECT, CONSEQUENTIAL, SPECIAL, OR INCIDENTAL DAMAGES OR LOSS, INCLUDING WITHOUT LIMITATION, LOSS OF PROFITS, LOSS OF OPPORTUNITIES, BUSINESS INTERRUPTION AND LOSS OF DATA, AND (2) DISCLAIMS ANY AND ALL EXPRESS OR IMPLIED WARRANTIES AND CONDITIONS RELATED TO SALE, USE OF PRODUCT, OR INFORMATION, INCLUDING WARRANTIES OR CONDITIONS OF MERCHANTABILITY, FITNESS FOR A PARTICULAR PURPOSE, ACCURACY OF INFORMATION, OR NONINFRINGEMENT.**
- Do not use or otherwise make available Product or related software or technology for any military purposes, including without limitation, for the design, development, use, stockpiling or manufacturing of nuclear, chemical, or biological weapons or missile technology products (mass destruction weapons). Product and related software and technology may be controlled under the applicable export laws and regulations including, without limitation, the Japanese Foreign Exchange and Foreign Trade Law and the U.S. Export Administration Regulations. Export and re-export of Product or related software or technology are strictly prohibited except in compliance with all applicable export laws and regulations.
- Please contact your TOSHIBA sales representative for details as to environmental matters such as the RoHS compatibility of Product. Please use Product in compliance with all applicable laws and regulations that regulate the inclusion or use of controlled substances, including without limitation, the EU RoHS Directive. **TOSHIBA ASSUMES NO LIABILITY FOR DAMAGES OR LOSSES OCCURRING AS A RESULT OF NONCOMPLIANCE WITH APPLICABLE LAWS AND REGULATIONS.**