

MAXIM

MAX1953 Evaluation Kit

General Description

The MAX1953 evaluation kit (EV kit) demonstrates two low-cost, buck-controller application circuits. The MAX1953 application circuit features an adjustable current limit. The 1MHz switching frequency renders a small footprint. The MAX1954 application circuit operates from a 3V to 13.2V input voltage range and is adjustable independent of the supply voltage. The MAX1954 switches at 300kHz and boasts 93% efficiency with the supplied components.

This EV kit comes with the MAX1953 and MAX1954 evaluation circuits fully assembled and tested.

Component List

DESIGNATION	QTY	DESCRIPTION
C1, C12	2	1 μ F, 10V X7R ceramic capacitors (0603) TDK C1608X7R1A105K
C2	1	0.22 μ F, 10V X7R ceramic capacitor (0603) Kemet C0603C224M8RAC
C3	1	22 μ F, 16V X5R ceramic capacitor (1210) TDK C3225X5R1C226K
C4	1	Not installed
C5	1	180 μ F, 2V, 9m Ω SP capacitor Panasonic EEFSX0D181R
C6	1	18pF \pm 5%, 50V C0H ceramic capacitor (0402) Taiyo Yuden UMK105CH180JW
C7	1	470pF \pm 10%, 50V X7R ceramic capacitor (0402) Taiyo Yuden UMK105BJ471KW
C8, C18	2	0.1 μ F \pm 10%, 16V X5R ceramic capacitors (0603) Taiyo Yuden EMK107BJ104KA
C9, C19	2	Not installed (0603)
C10	1	1500pF \pm 10%, 50V X7R ceramic capacitor (0603) TDK C1608X7R1H152K

Component List continued on next page.

Features

- ◆ Low-Cost Current-Mode Controllers
- ◆ Fixed-Frequency Pulse-Width Modulation (PWM)
- ◆ 0.8V (min) Output Voltage
- ◆ Operates from Low 3V Input Voltage
- ◆ MAX1953
 - 1MHz Switching Frequency
 - Small Component Size, Low Cost
 - Adjustable Current Limit
- ◆ MAX1954
 - 3V to 13.2V Input Voltage
 - 93% Efficiency
 - 300kHz Switching Frequency
- ◆ Shutdown Feature
- ◆ All n-Channel MOSFET Design for Low Cost
- ◆ No Current-Sense Resistor Needed
- ◆ Internal Digital Soft-Start
- ◆ Surface-Mount Components
- ◆ Thermal-Overload Protection
- ◆ Small 10-Pin μ MAX[®] Package
- ◆ MAX1953/MAX1954 Circuit Fully Assembled and Tested

Ordering Information

PART	TEMP RANGE	IC PACKAGE
MAX1953EVKIT	0°C to +70°C	10 μ MAX

Recommended Equipment

- Digital multimeter (DMM)
- Ammeter (optional)
- Power supply 1: 3V_{DC} to 14V_{DC} at 3A
- Power supply 2: 3V_{DC} to 6V_{DC} at 100mA

μ MAX is a registered trademark of Maxim Integrated Products, Inc.

MAX1953 Evaluation Kit

Component List (continued)

DESIGNATION	QTY	DESCRIPTION
C11	1	22 μ F \pm 20%, 6.3V X5R ceramic capacitor (1206) Taiyo Yuden JMK316 BJ226ML
C14	1	Not installed (0402)
C15	1	270pF \pm 5%, 50V C0G ceramic capacitor (0402) Taiyo Yuden UMK105 CG271JW
C16, C17	2	10 μ F \pm 10%, 6.3V X5R ceramic capacitors (0805) Taiyo Yuden JMK212 BJ106KG
C20	1	4700pF \pm 10%, 50V X7R ceramic capacitor (0603) TDK C1608X7R1H472K
D1, D2	2	Schottky diodes (SOT23-F) Central Semiconductor CMPSH1-4
JU1, JU2, JU4	3	2-pin headers Sullins PTC36SAAN (36-pin strip, cut to size as needed)
JU3	1	3-pin header Sullins PTC36SAAN (36-pin strip, cut to size as needed)

DESIGNATION	QTY	DESCRIPTION
L1	1	2.7 μ H, 6.6A, 12m Ω inductor Coilcraft DO3316P-272HC
L2	1	1 μ H, 3.6A, 20m Ω inductor TOKO 817FY-1R0M
N1, N2	2	Dual n-channel MOSFETs, 20V, 7.5A, 0.018 Ω (SO-8) Fairchild FDS6890A
R1	1	7.15k Ω \pm 1% resistor (0603)
R2, R7	2	8.06k Ω \pm 1% resistors (0603)
R3	1	82k Ω \pm 5% resistor (0603)
R4, R9	2	Not installed (0603)
R5, R10	2	2 Ω \pm 5% resistors (0603)
R6	1	10.2k Ω \pm 1% resistor (0603)
R8	1	27k Ω \pm 5% resistor (0603)
U1	1	Maxim MAX1954EUB
U2	1	Maxim MAX1953EUB
—	4	Shunts Sullins STC02SYAN Digi-key S9000-ND

Component Suppliers

SUPPLIER	COMPONENT	PHONE	WEBSITE
Central Semiconductor	Diodes	516-435-1110	www.centralsemi.com
Coiltronics	Inductors	561-752-5000	www.coiltronics.com
Fairchild Semiconductor	MOSFETs	408-721-2181	www.fairchildsemi.com
Kemet	Capacitors	864-963-6300	www.kemet.com
Murata	Capacitors	770-436-1300	www.murata.com
Taiyo Yuden	Capacitors	408-573-4150	www.t-yuden.com
TOKO	Inductors	800-745-8656	www.toko.com
TDK	Capacitors	847-803-6100	www.component.tdk.com

Note: Indicate you are using the MAX1953/MAX1954 when contacting these component suppliers.

Quick Start

The MAX1953/MAX1954 application circuits are fully assembled and tested. Follow the steps below to verify board operation.

MAX1954

- 1) Preset DC power supply 1 to 12V, and power supply 2 to 5V. Turn off the power supplies.
- 2) Verify that there is no shunt at JU1 and JU2.
- 3) Connect the positive lead of power supply 2 to the VIN pad and connect the negative lead of the power supply to GND.
- 4) Connect the positive lead of power supply 1 to the HSD pad, and connect the negative lead on the power supply to the GND pad.
- 5) Turn on power supply 1.
- 6) Turn on power supply 2.

MAX1953 Evaluation Kit

Evaluates: MAX1953/MAX1954

- 7) Verify that the voltage at VOUT is ~1.5V.
- 8) Connect a 5A load between VOUT and GND.
- 9) Verify that the voltage at VOUT is ~1.5V.

MAX1953

- 1) Preset DC power supply 1 to 3.3V. Turn off the power supply.
- 2) Ensure that there is a shunt between positions 1 and 2 at JU3.
- 3) Verify that there is no shunt at JU4.
- 4) Connect the positive lead of power supply 1 to the VIN1 pad and connect the negative lead to the GND1 pad.
- 5) Turn on the power supply.
- 6) Verify that the voltage at VOUT1 is ~1.8V.
- 7) Connect a 3A load between VOUT1 and GND1.
- 8) Verify that the voltage at VOUT1 is ~1.8V.

Detailed Description

Evaluating Other Output Voltages

The MAX1953/MAX1954 application circuits come assembled with output voltages of 1.8V and 1.5V, respectively. The MAX1953/MAX1954 are capable of adjustable output voltage settings from 0.8V to $0.86 \times V_{IN}$. To adjust the output voltage, place an $8.06k\Omega \pm 1\%$ resistor at R2 (R5) and a 1% resistor at R1 (R4) with a value corresponding to the equation:

$$R1 (R4) = 8.06 \times 10^3 \times ((V_{OUT} / 0.8) - 1)$$

VOUT can not exceed VIN.

The compensation network may need to be optimized for each output voltage. Refer to the *Stability and Compensation* section of the MAX1953/MAX1954/MAX1957 data sheet for the method to calculate the compensation components.

Using a Single Power Supply (MAX1954)

To use a single power supply with the MAX1954, the power-supply voltage must be between 3V and 5.5V. Connect the positive lead of the power supply to the HSD pad on the EV kit, and connect the negative lead of the power supply to the GND pad on the EV kit. Install a shunt on JU1.

Jumper Settings

JU2 and JU4 Functions (Shutdown Mode)

The MAX1953/MAX1954 feature a shutdown mode to minimize the quiescent current. To shut down the MAX1953, place a shunt between pins 1 and 2 on JU4. To shut down the MAX1954, place a shunt between pins 1 and 2 on JU2.

JU1 Function (HSD Control, MAX1954)

The HSD and IN pins on the MAX1954 can be connected when using input voltages lower than 5.5V. Place a shunt on JU1 to connect the HSD and IN pins.

Setting the Current Limit (MAX1953)

Use JU3 to set the short-circuit current-limit threshold for the MAX1953. Short JU3 between pins 1 and 2 for a 105mV threshold, between 2 and 3 for a 320mV threshold, or remove the shunt from JU3 for a 210mV threshold.

Input Capacitance Guidelines

An oscillation may occur in the input voltage when using the MAX1953 EV kit that shows up on the output. This is typically due to long input leads. An LC "tank" circuit is formed with the inductance of the input leads and the input capacitance. Use very short leads or add a high equivalent series resistance (ESR) capacitor (aluminum electrolytic or tantalum) at the input to stop this oscillation. This "detunes" the LC tank circuit and effectively stops the oscillation.

Table 1. JU3 Positions

SHUNT LOCATION	ILIM	Vcs (mV)
Between 1 and 2	Connected to GND	105
None	Unconnected	210
Between 2 and 3	Connected to IN	320

MAX1953 Evaluation Kit

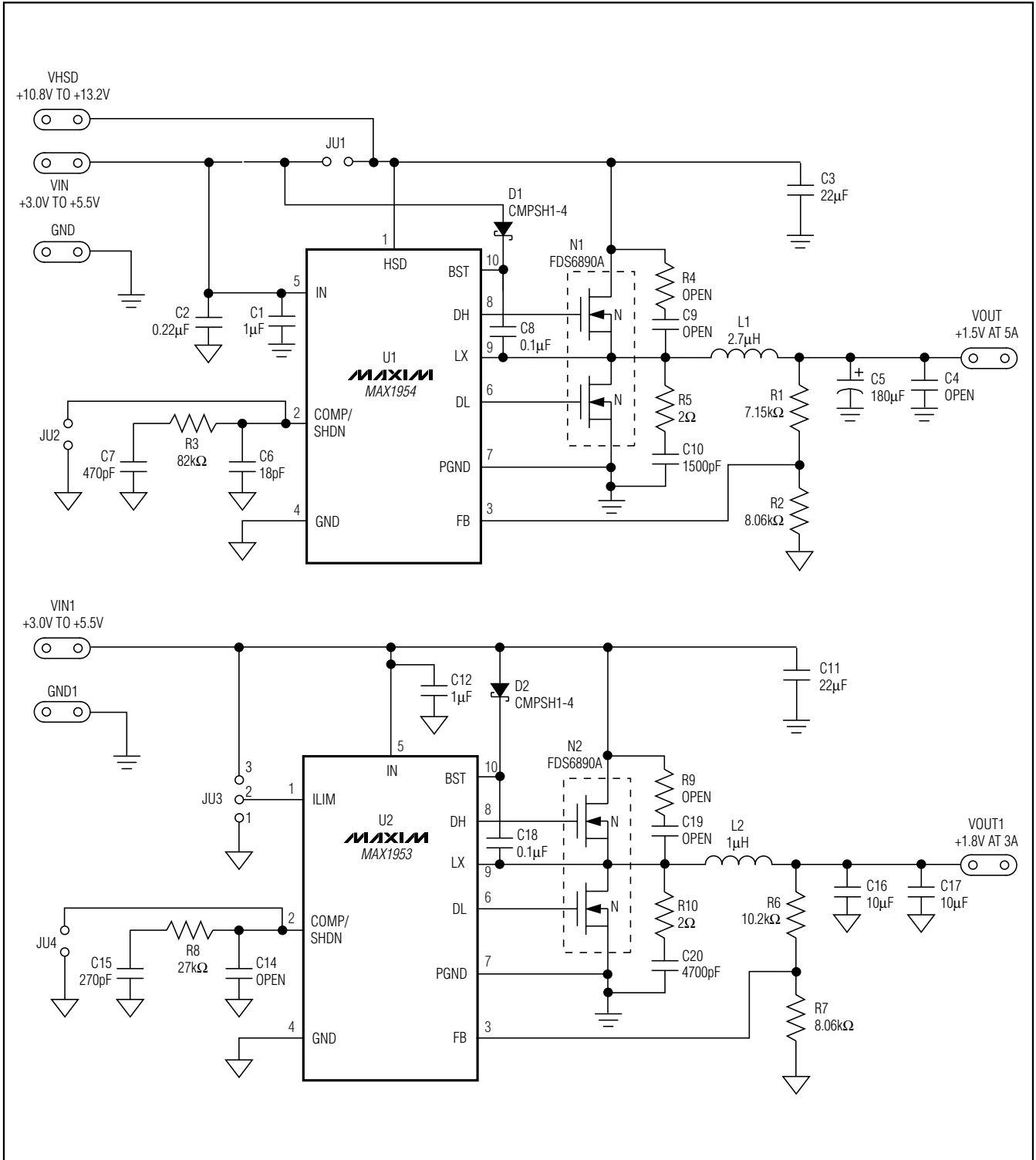

Figure 1. MAX1953 EV Kit Schematic

MAX1953 Evaluation Kit

Evaluates: MAX1953/MAX1954

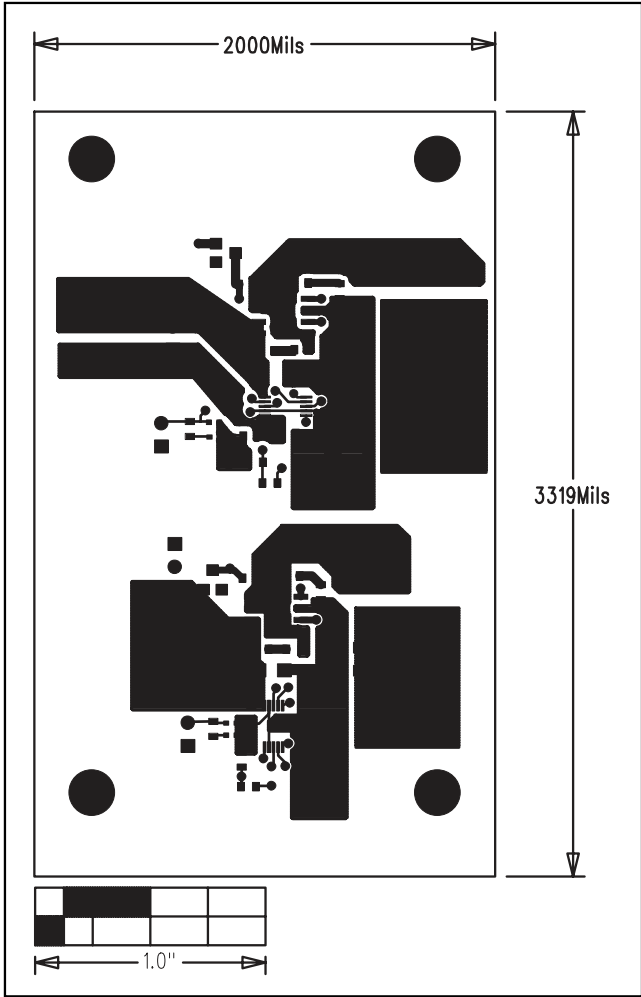
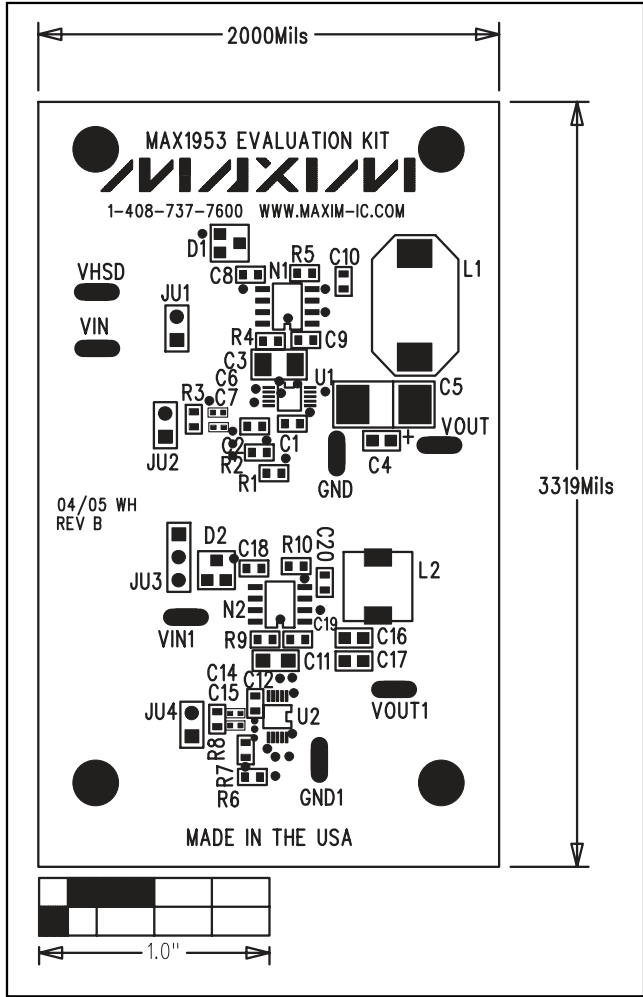

Figure 2. MAX1953 EV Kit Component Placement Guide—Component Side Silkscreen

Figure 3. MAX1953 EV Kit PC Board Layout—Component Side

MAX1953 Evaluation Kit

Evaluates: MAX1953/MAX1954

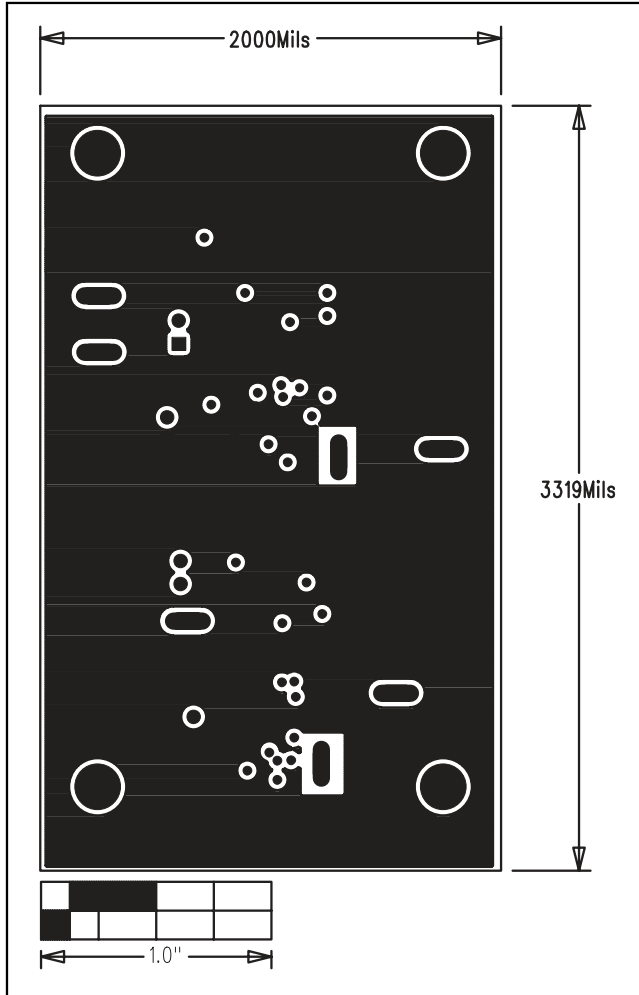

Figure 4. MAX1953 EV Kit PC Board Layout—Inner Layer 1

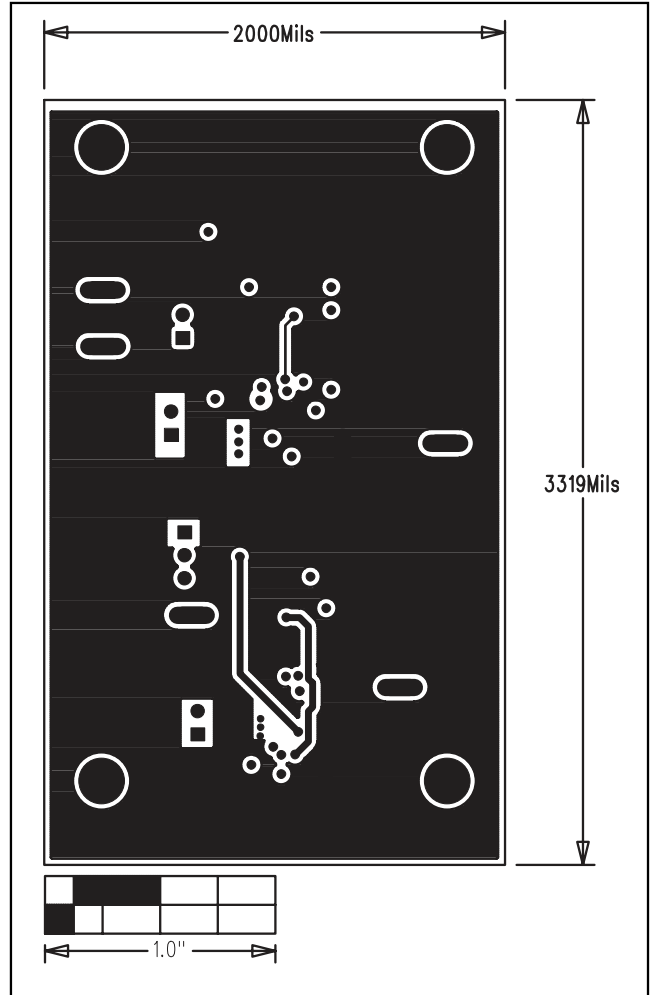

Figure 5. MAX1953 EV Kit PC Board Layout—Inner Layer 2

MAX1953 Evaluation Kit

Evaluates: MAX1953/MAX1954

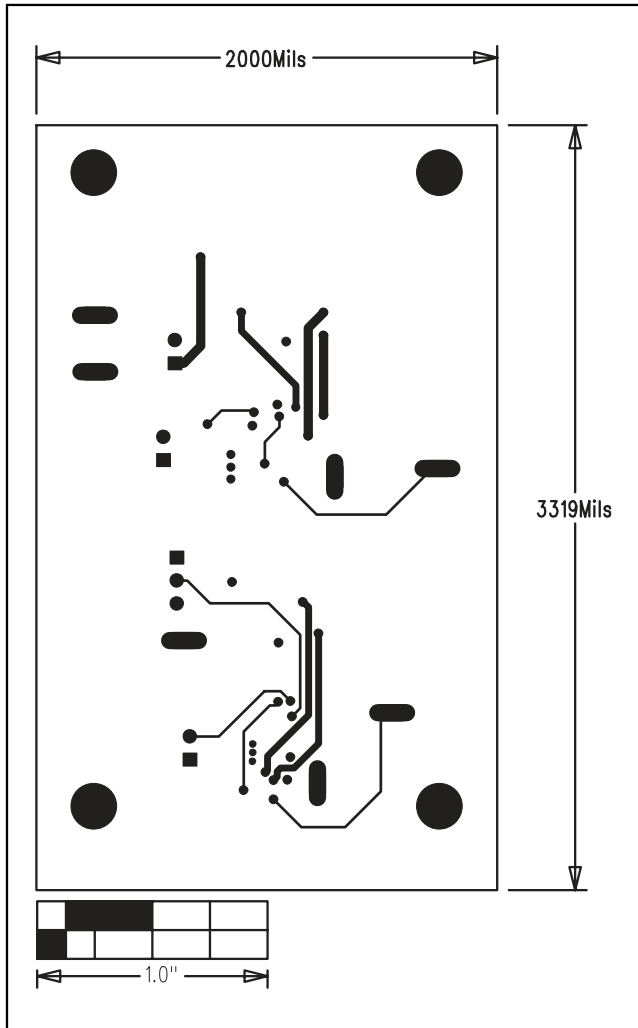

Figure 6. MAX1953 EV Kit PC Board Layout—Solder Side

Maxim cannot assume responsibility for use of any circuitry other than circuitry entirely embodied in a Maxim product. No circuit patent licenses are implied. Maxim reserves the right to change the circuitry and specifications without notice at any time.

Maxim Integrated Products, 120 San Gabriel Drive, Sunnyvale, CA 94086 408-737-7600 _____ 7