

BGR405

NPN Silicon RF Transistor With Bias Circuitry

Small Signal Discretes



Never stop thinking

Edition 2008-06-06

**Published by Infineon Technologies AG,
85579 Neubiberg, Germany**

**© Infineon Technologies AG 2008.
All Rights Reserved.**

Attention please!

The information herein is given to describe certain components and shall not be considered as a guarantee of characteristics.

Terms of delivery and rights to technical change reserved.

We hereby disclaim any and all warranties, including but not limited to warranties of non-infringement, regarding circuits, descriptions and charts stated herein.

Information

For further information on technology, delivery terms and conditions and prices please contact your nearest Infineon Technologies Office (www.infineon.com).

Warnings

Due to technical requirements components may contain dangerous substances. For information on the types in question please contact your nearest Infineon Technologies Office.

Infineon Technologies Components may only be used in life-support devices or systems with the express written approval of Infineon Technologies, if a failure of such components can reasonably be expected to cause the failure of that life-support device or system, or to affect the safety or effectiveness of that device or system. Life support devices or systems are intended to be implanted in the human body, or to support and/or maintain and sustain and/or protect human life. If they fail, it is reasonable to assume that the health of the user or other persons may be endangered.

BGR405, NPN Silicon RF Transistor With Bias Circuitry

Revision History: 2008-06-06, Rev. 1.0

Prevision History: no previous version

Page	Subjects (major changes since last revision)

Trademarks

SIEGET[®] is a registered trademark of Infineon Technologies AG.

1 NPN Silicon RF Transistor With Bias Circuitry*

Features

- Noise figure $NF = 1.0$ dB at 0.4 GHz
- Gain $S_{21} = 7.5$ dB at 0.4 GHz
- On chip bias circuitry, 0.85 mA bias current at $V_{CC} = 1.2$ V
- SIEGET ® 25 GHz f_T -Line
- Pb-free (RoHS compliant) package

* Short term description

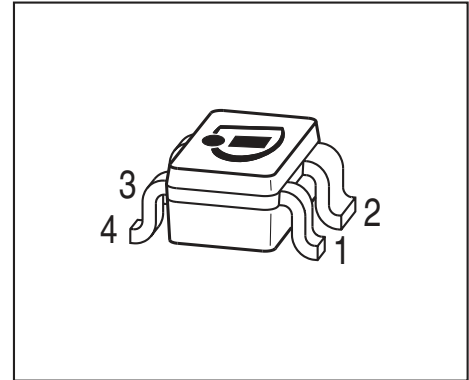

Applications

- LNAs

2 Description

The BGR405 is a monolithic silicon amplifier with a NPN silicon RF transistor and integrated resistors for biasing.

Type	Package	Marking
BGR405	SOT343	AVs

Note: ESD (Electrostatic discharge) sensitive device, observe handling precaution!

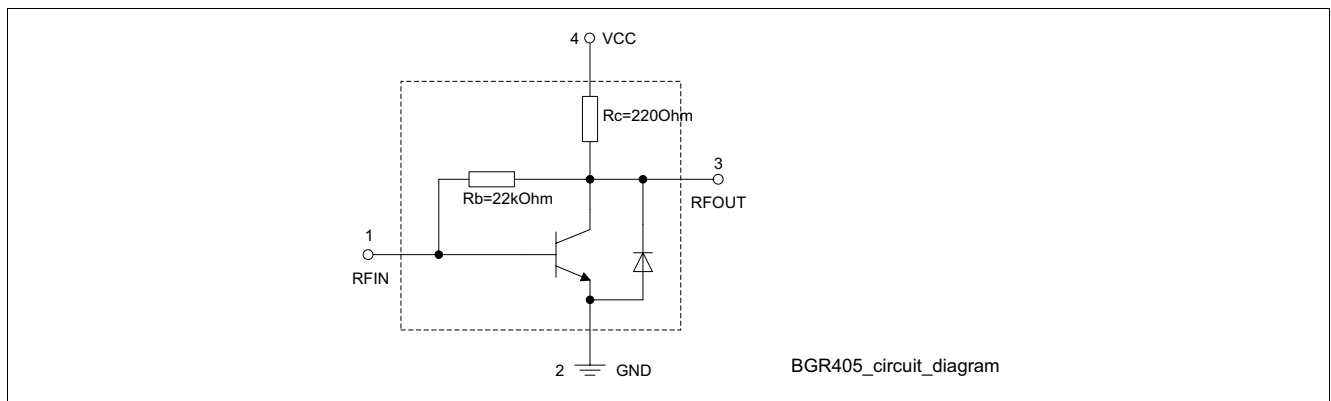

Figure 1 Circuit diagram

Note: Due to design there is an additional diode between emitter and collector, which does not effect normal operation for common emitter configuration.

Table 1 Pinning table

Pin	Function
1	RFIN
2	GND
3	RFOUT
4	VCC

2.1 Maximum Ratings

Note: All Voltages refer to GND-node

Table 2 Maximum ratings

Parameter	Symbol	Value	Unit
Current at pin VCC	I_{CC}	12	mA
Voltage at pin VCC	V_{CC}	5	V
Current at pin RFIN	I_B	0.8	mA
Voltage at pin RFIN	V_B	2	V
Current at pin RFOUT ¹⁾	I_{OUT}	12	mA
Voltage at pin RFOUT	V_{OUT}	4.1	V
Total power dissipation ²⁾ $T_S = 120\text{ °C}$	P_{tot}	50	mW
Operation junction temperature range	T_{jo}	-65... 150	°C
Storage junction temperature range	T_{jstg}	-65... 150	°C

1) Applicable if VCC and RFOUT are shorted, otherwise a coupling capacitor at RFOUT is demanded

2) T_S is measured on the emitter (GND) lead at the soldering point to the pcb

Note: Stresses above the max. values listed here may cause permanent damage to the device. Exposure to absolute maximum rating conditions even only for a short moment may affect device reliability. Maximum ratings are absolute ratings; exceeding only one of these values may cause irreversible damage to the integrated circuit. Absolute maximum ratings typically differ heavily from recommended operation conditions.

2.2 Thermal Resistance

Table 3 Thermal Resistance

Parameter	Symbol	Value	Unit
Junction - soldering point ¹⁾	R_{thJS}	≤ 595	K/W

1) For calculation of R_{thJA} please refer to Application Note Thermal Resistance.

3 Electrical Characteristics

Table 4 DC characteristics at $T_A = 25\text{ °C}$, unless otherwise specified

Parameter	Symbol	Values			Unit	Note / Test Condition
		Min.	Typ.	Max.		
Device current	I_{CC}	0.6	0.85	1.1	mA	$V_{CC} = 1.2\text{ V}$

**Table 5 AC characteristics (measured in test circuit [Figure 2](#); verified by random sampling)
 $T_A = 25\text{ °C}$, $V_{CC} = 1.2\text{ V}$, $Z_0 = 50\text{ }\Omega$, unless otherwise specified**

Parameter	Symbol	Values			Unit	Note / Test Condition
		Min.	Typ.	Max.		
Insertion power gain	S_{21}		7.5 7.0		dB	$F = 0.4\text{ GHz}$ $f = 1.8\text{ GHz}$
Reverse isolation	S_{12}		-37 -25		dB	$F = 0.4\text{ GHz}$ $f = 1.8\text{ GHz}$
Noise figure, $Z_S = Z_{Sopt}$	NF		1.0 1.6		dB	$F = 0.4\text{ GHz}$ $f = 1.8\text{ GHz}$
Third order intercept point at the output ¹⁾	OIP_3		-9 14.5		dBm	$F = 0.4\text{ GHz}$, $V_{CC} = 1.2\text{ V}$ $f = 1.8\text{ GHz}$, $V_{CC} = 4\text{ V}$
1 dB compression point at the output	OP_{-1dB}		-19 -0.5		dBm	$F = 0.4\text{ GHz}$, $V_{CC} = 1.2\text{ V}$ $f = 1.8\text{ GHz}$, $V_{CC} = 4\text{ V}$
Return loss input	S_{11}		-0.4 -1.8		dB	$F = 0.4\text{ GHz}$ $f = 1.8\text{ GHz}$
Return loss output	S_{22}		-4.0 -6.0		dB	$F = 0.4\text{ GHz}$ $f = 1.8\text{ GHz}$

1) OIP_3 value depends on termination of all intermodulation frequency components. Termination used for this measurement is $50\text{ }\Omega$ from 0.1 MHz to 6 GHz.

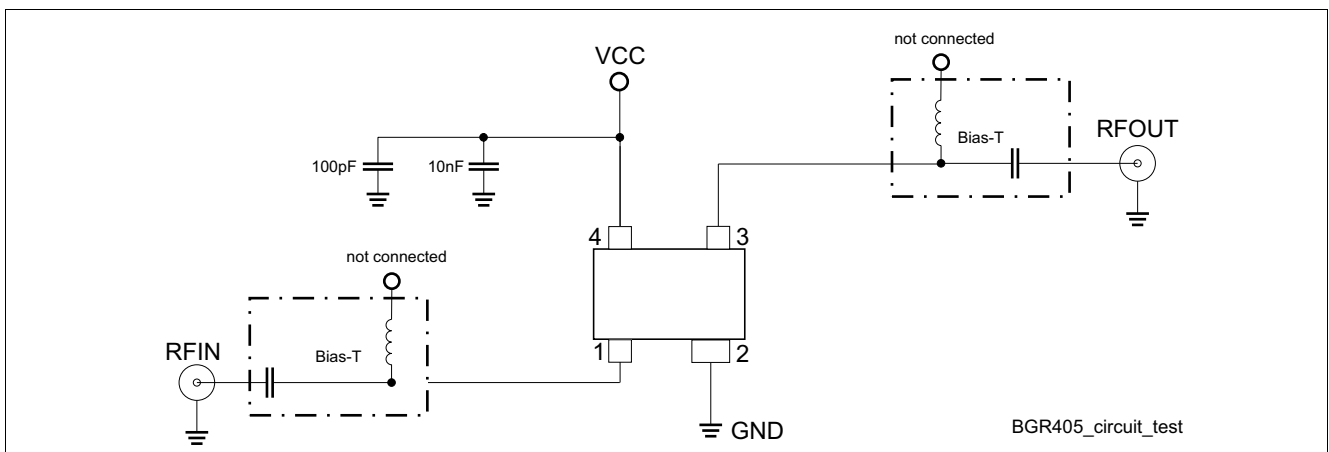
Figure 2 BGR405 test circuit

4 Package Information

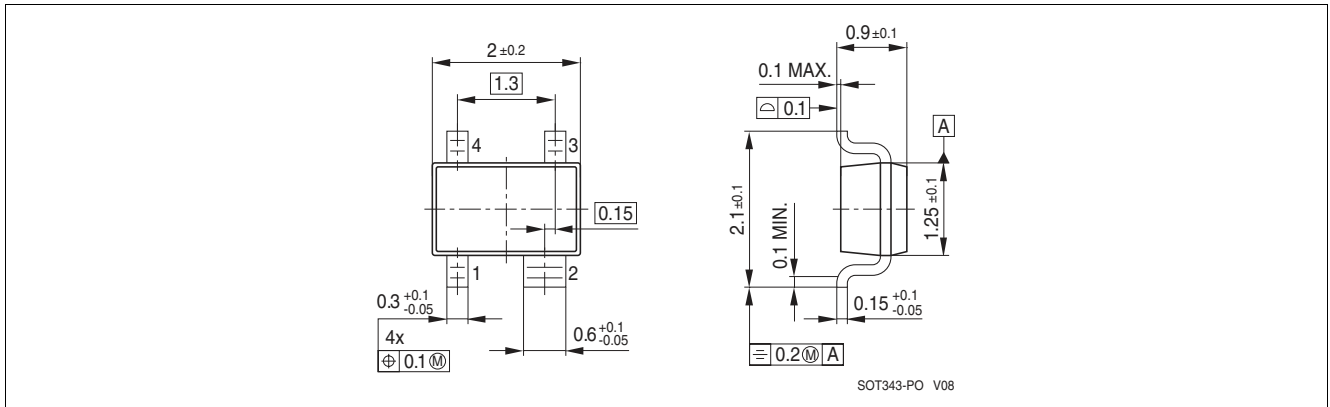

Figure 3 Package Outline SOT343

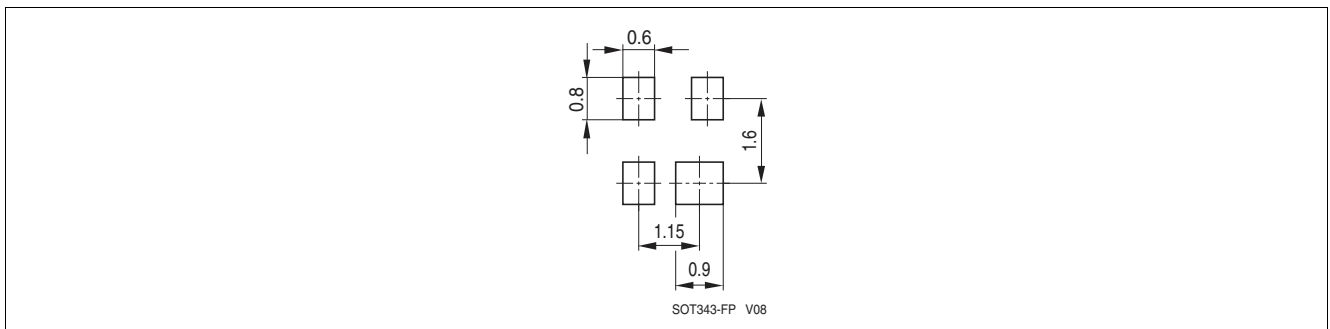

Figure 4 Footprint of SOT343

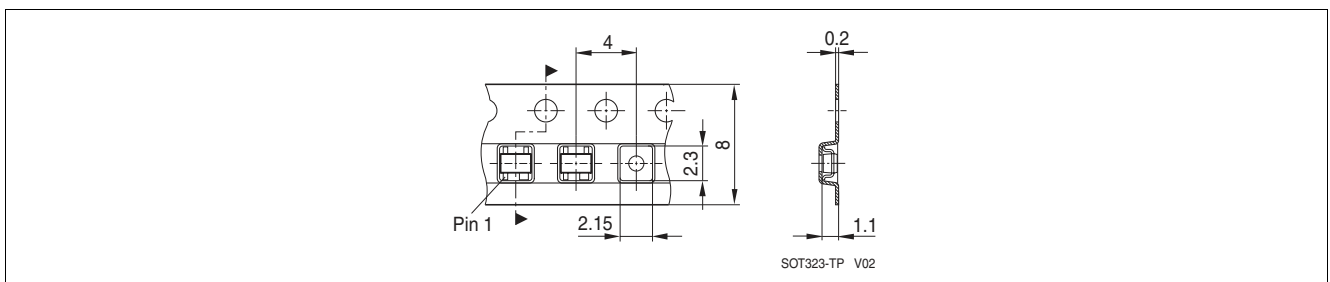

Figure 5 Tape of SOT343