



MEZS7-SolarCharger

Wide Input Range 4.5A I²C Controlled SW Charger with NVDC Power Path and USB OTG Solution Module

DESCRIPTION

The MEZS7-SolarCharger is a complete solution module that uses the MP2731 NVDC buck charger with an MCU for maximum power point tracking (MPPT) designs with a photovoltaic (PV) panel.

The MP2731 charger used in the solution fully integrates power switches with built-in robust charging protections including JEITA, a configurable safety timer, voltage- and current-sensing circuitry, ADC, and an I²C interface, which all significantly reduce system cost. The integrated reverse-blocking FET blocks the path from the battery load to the PV panel when the panel is under low irradiance.

The input voltage/current and output voltage/current are sampled through an 8-bit ADC, which can be easily communicated to the external MCU through the I²C interface.

ELECTRICAL SPECIFICATIONS

Parameter	Symbol	Value	Units
Input voltage	V _{IN}	4.5 to 16	V
Charge full voltage	V _{BATT_REG}	4.2, I ² C-configurable	V
Charge current	I _{CC}	1.84, I ² C-configurable	A
Input voltage regulation	V _{IN_MIN}	4.5, I ² C-configurable	V
Input current limit	I _{IN_LIM}	0.5, I ² C-configurable	A

FEATURES

- 4.5V to 16V Operating Input Voltage Range
- Up to 22V Sustainable Voltage
- High-Efficiency, 4.5A, 1.35MHz Buck Charger
 - 93% Efficiency in a 9V Input 5W System
 - 98% MPPT Accuracy
- Fully Integrated Power Switches with Built-In Robust Charging Protection
- Adjustable Minimum Input Voltage Regulation with 100mV Step for Maximum Power Point Tracking
- Dormancy Function, Only V_{IN}-Eligible Open Working Mode
- JEITA for Battery Temperature Protection in Charge Mode
- Battery Charging Safety Timer
- Thermal Regulation and Thermal Shutdown
- Small (25mmx25mm) Core Circuit Area

APPLICATIONS

- MPPT Applications
- Outdoor IoT Systems
- Outdoor Lighting
- Outdoor Solar Surveillance Cameras

All MPS parts are lead-free, halogen-free, and adhere to the RoHS directive. For MPS green status, please visit the MPS website under Quality Assurance. "MPS", the MPS logo, and "Simple, Easy Solutions" are trademarks of Monolithic Power Systems, Inc. or its subsidiaries.

MEZS7-SOLARCHARGER SOLUTION MODULE



(LxWxH) 6.3cmx6.3cmx0.45cm

Board Number	MPS IC Number
MEZS7-SolarCharger	MP2731

QUICK START GUIDE

This solution module is designed for the MP2731 when the device is used as an MPPT charger. Its layout accommodates most commonly used capacitors. For more details regarding the operation of the MP2731, refer to the MP2731 datasheet.

1. Connect the PV panel to the input port (see Figure 1).

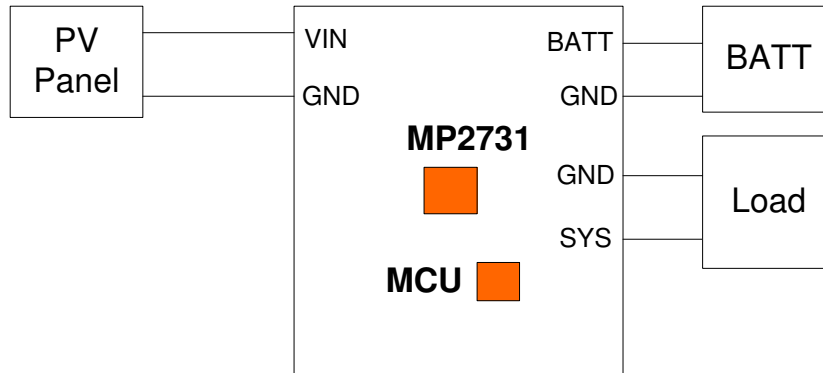

Figure 1: Set-Up for MPPT System

2. Connect the load to the system port.
3. Connect the single-cell battery (or the battery simulator set to 3.7V with a 5A limit) between the battery terminals.
4. Turn the input power supply on after the making connections. The board should automatically start up.

MEZS7-SOLARCHARGER BILL OF MATERIALS

Qty	Ref	Value	Description	Package	Manufacturer	Manufacturer P/N
1	C1	1 μ F	Ceramic capacitor, 25V, X7R	0603	muRata	GRM188R71E105KA12D
1	C2	10 μ F	Ceramic capacitor, 50V, X5R	1206	muRata	GRM31CR61H106KA12L
1	C4	100nF	Ceramic capacitor, 25V, X5R	1206	muRata	GCM188R71C104KA37D
1	C5	47nF	Ceramic capacitor, 25V, X5R	0603	muRata	GRM188R71H473KA61D
1	C7	10 μ F	Ceramic capacitor, 16V, X5R	0603	muRata	GRM188R61C106KAALD
2	C9, C11	22 μ F	Ceramic capacitor, 10V, X7R	1206	muRata	GRM31CR71A226KE15L
1	C3	NC	Ceramic capacitor	1206		
1	C12	NC	Ceramic capacitor	0805		
4	C6, C8, C10, C13	NC	Ceramic capacitor	0603		
1	L1	1 μ H	Inductor, 1 μ H, 21m Ω , 7A	SMD	Cyntec	HTEP32251B-1R0MIR-89
1	LED1		Red LED	0805	Bright LED	BL-HUF35A-TRB
2	R1,R2	2k Ω	Film resistor, 1%	0603	Yageo	RC0603FR-072KL
1	RILIM	1k Ω	Film resistor, 1%	0603	Yageo	RC0603FR-071KL
4	RT1, RT2, R8, R9	10k Ω	Film resistor, 1%	0603	Yageo	RC0603FR-0710KL
5	R3, R4, R6, R10, R11	0 Ω	Film resistor, 1%	0603	Yageo	RC0603FR-070RL
1	R5	100k Ω	Film resistor, 5%	0603	Yageo	RC0603JR-07100KL
1	R7	NC	Film resistor,	0603		
2	JP1, JP2		2.54mm connector			
2	JP1, JP2		2.54mm short			
1	P1		Header, 5-pin, dual row			
10	GND, DISC, NTC, INT, VREF, NTC_BAT, BATT, GND, DSCL, DSDA		2.54mm connector			

MEZS7-SOLARCHARGER BILL OF MATERIALS (continued)

Qty	Ref	Value	Description	Package	Manufacturer	Manufacturer P/N
6	VIN, PGND, VBATT, PGND, PGND, VSYS		2mm pin			
11	GND, VPMID, DP, DM, VIN, VBATT, VSYS, GND, SW, BST, STAT		Test point			
1	U1	MP2731GQC -0001	I ² C-controlled switching charger with NVDC power path and USB OTG	QFN-26 (3.5mmx 3.5mm)	MPS	MP2731GQC-0001
1	U2	NC	Micro-B USB receptacle	7.5mmx 2.45mmx 5mm		
1	U3		MCU	QFN-20 (3mmx3mm)	ABOV	MC96F1206USBN

SOLUTION MODULE TEST RESULTS

Performance curves and waveforms are tested on the solution module. $V_{IN} = 4V$ to $16.5V$, single-cell battery, unless otherwise noted.

Efficiency vs. Battery Voltage

PV panel at 9V output

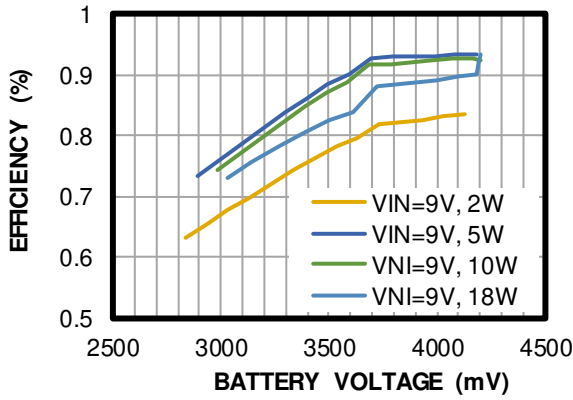

Efficiency vs. Battery Voltage

PV panel at 12V output

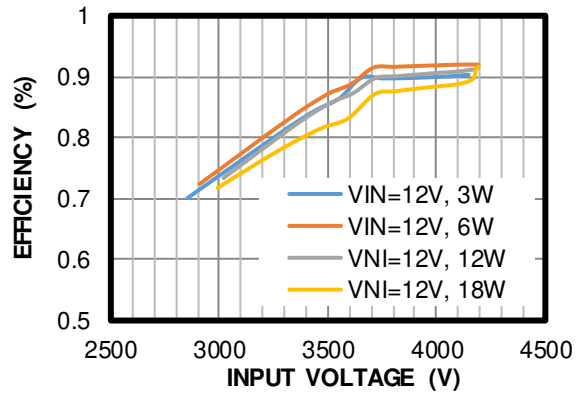

Efficiency vs. Battery Voltage

PV panel at 5V output

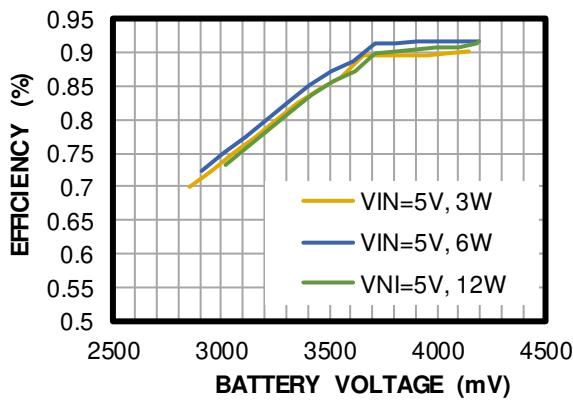

SOLUTION MODULE TEST RESULTS *(continued)*

Performance curves and waveforms are tested on the solution module. $V_{IN} = 4V$ to $16.5V$, single-cell battery, real PV panel, unless otherwise noted.

MPPT Process for PV Panel from Start-Up to Steady State

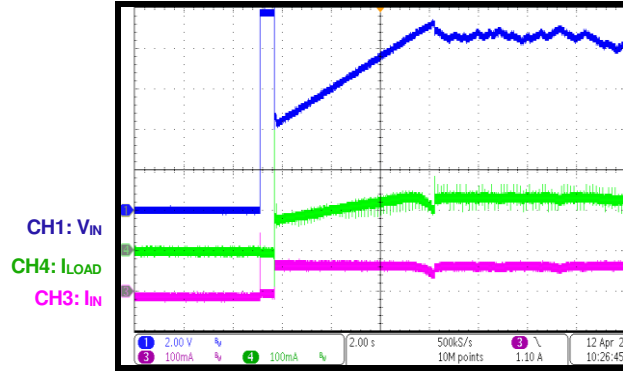

MPPT Behavior during Charging Cycle

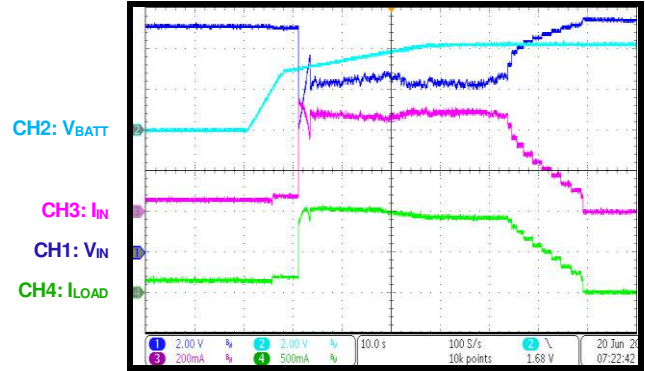

Tracking Performance for Partially Shaded Sunlight
PV panel at about 5V

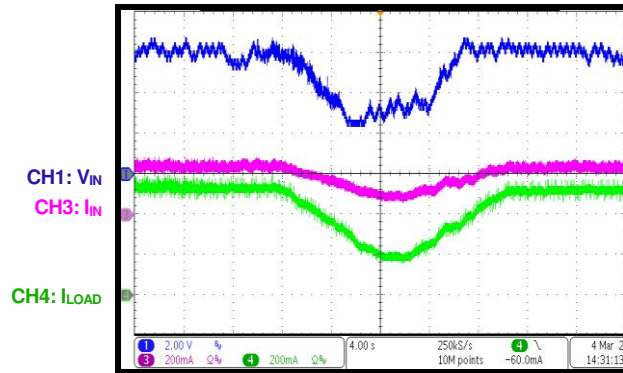

Tracking Performance for Partially Shaded Sunlight
PV panel at about 8V

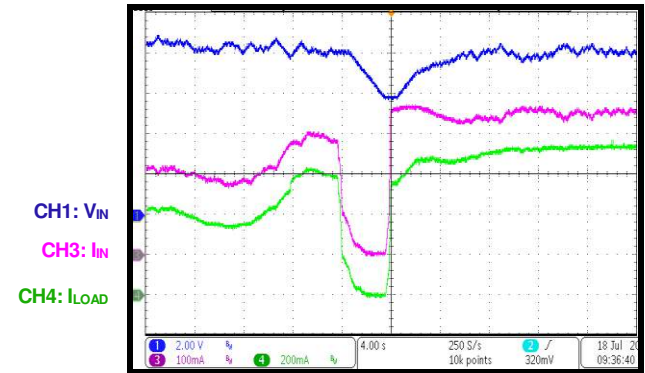

Tracking Performance in Natural Lighting Environment
PV panel at about 5V

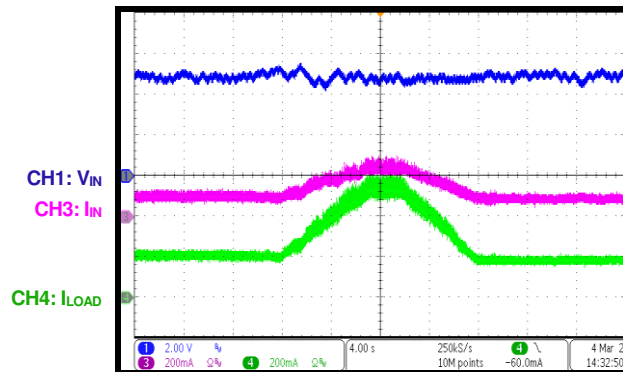

Tracking Performance in Natural Lighting Environment
PV panel at about 8V

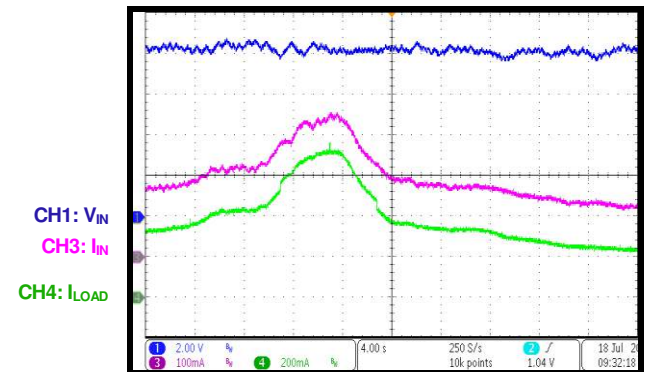

PCB LAYOUT

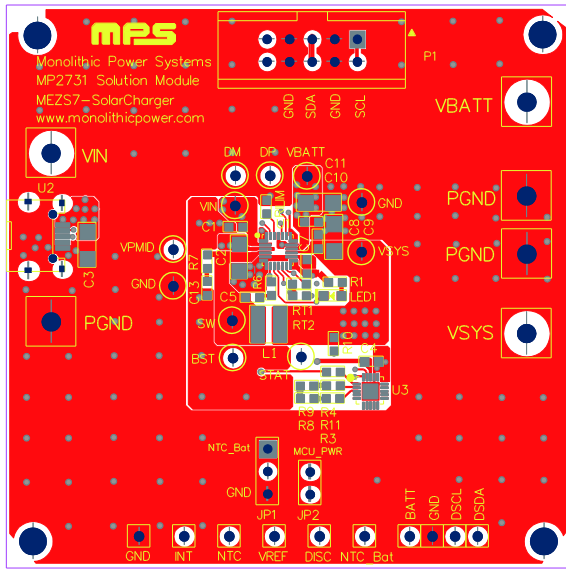

Figure 3: Top and Silkscreen Layer

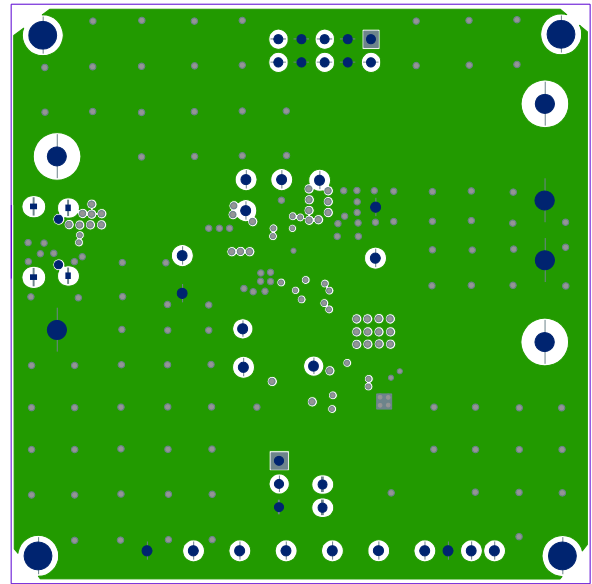

Figure 4: Mid-Layer 1

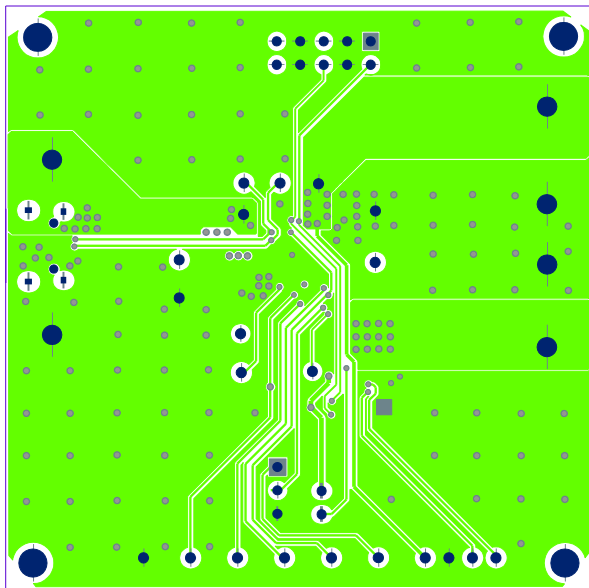

Figure 5: Mid-Layer 2

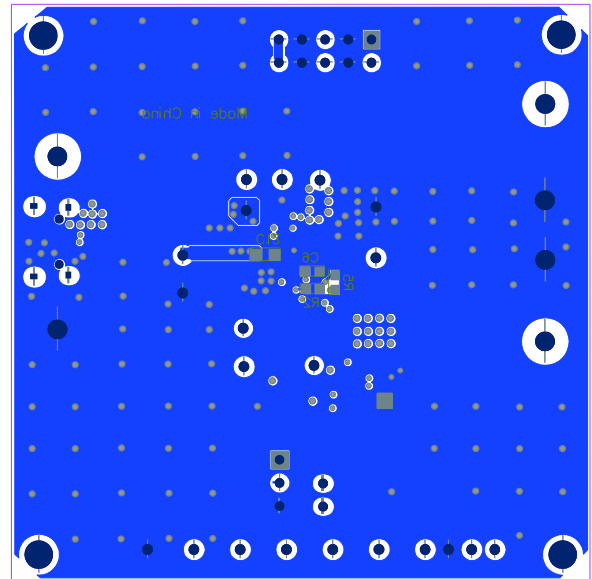

Figure 6: Bottom Layer



Revision History

Revision #	Revision Date	Description	Pages Updated
1.0	6/12/2020	Initial Release	-

Notice: The information in this document is subject to change without notice. Users should warrant and guarantee that third-party Intellectual Property rights are not infringed upon when integrating MPS products into any application. MPS will not assume any legal responsibility for any said applications.