

# IRF8721PbF

HEXFET® Power MOSFET

## Applications

- Control MOSFET of Sync-Buck Converters used for Notebook Processor Power
- Control MOSFET for Isolated DC-DC Converters in Networking Systems

## Benefits

- Very Low Gate Charge
- Low  $R_{DS(on)}$  at 4.5V  $V_{GS}$
- Low Gate Impedance
- Fully Characterized Avalanche Voltage and Current
- 20V  $V_{GS}$  Max. Gate Rating
- Lead-Free

## Description

The IRF8721PbF incorporates the latest HEXFET Power MOSFET Silicon Technology into the industry standard SO-8 package. The IRF8721PbF has been optimized for parameters that are critical in synchronous buck operation including  $R_{ds(on)}$  and gate charge to reduce both conduction and switching losses. The reduced total losses make this product ideal for high efficiency DC-DC converters that power the latest generation of processors for Notebook and Netcom applications.

## Absolute Maximum Ratings

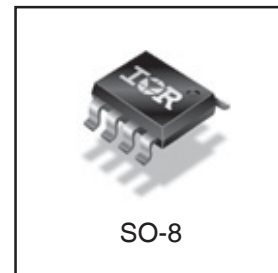
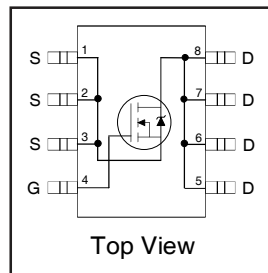
|                                | Parameter                                       | Max.         | Units |
|--------------------------------|---|--------------|-------|
| $V_{DS}$                       | Drain-to-Source Voltage                         | 30           | V     |
| $V_{GS}$                       | Gate-to-Source Voltage                          | ± 20         |       |
| $I_D @ T_A = 25^\circ\text{C}$ | Continuous Drain Current, $V_{GS} @ 10\text{V}$ | 14           | A     |
| $I_D @ T_A = 70^\circ\text{C}$ | Continuous Drain Current, $V_{GS} @ 10\text{V}$ | 11           |       |
| $I_{DM}$                       | Pulsed Drain Current ①                          | 110          |       |
| $P_D @ T_A = 25^\circ\text{C}$ | Power Dissipation                               | 2.5          | W     |
| $P_D @ T_A = 70^\circ\text{C}$ | Power Dissipation                               | 1.6          |       |
|                                | Linear Derating Factor                          | 0.02         | W/°C  |
| $T_J$                          | Operating Junction and                          | -55 to + 150 | °C    |
| $T_{STG}$                      | Storage Temperature Range                       |              |       |

## Thermal Resistance

|                 | Parameter                | Typ. | Max. | Units |
|-----------------|--------------------------|------|------|-------|
| $R_{\theta JL}$ | Junction-to-Drain Lead ⑤ | —    | 20   | °C/W  |
| $R_{\theta JA}$ | Junction-to-Ambient ④⑤   | —    | 50   |       |

Notes ① through ⑤ are on page 9

| $V_{DSS}$ | $R_{DS(on)}$ max              | Qg    |
|-----------|-------------------------------|-------|
| 30V       | 8.5mΩ @ $V_{GS} = 10\text{V}$ | 8.3nC |



## Static @ $T_J = 25^\circ\text{C}$ (unless otherwise specified)

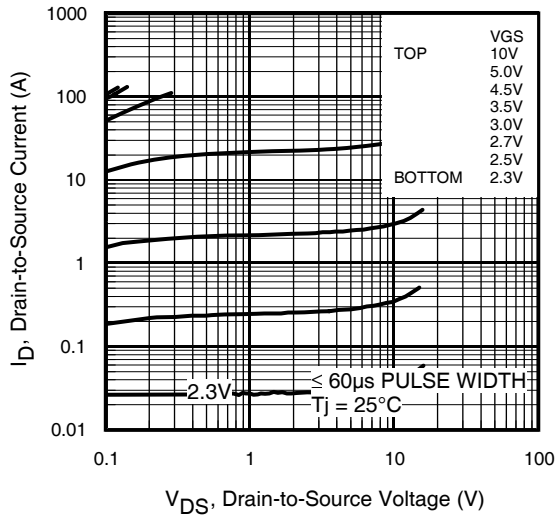
|                              | Parameter                            | Min. | Typ.  | Max. | Units | Conditions  |
|------------------------------|--------------------------------------|------|-------|------|-------|---|
| $BV_{DSS}$                   | Drain-to-Source Breakdown Voltage    | 30   | —     | —    | V     | $V_{GS} = 0V, I_D = 250\mu A$   |
| $\Delta BV_{DSS}/\Delta T_J$ | Breakdown Voltage Temp. Coefficient  | —    | 0.021 | —    | V/°C  | Reference to $25^\circ\text{C}, I_D = 1mA$  |
| $R_{DS(on)}$                 | Static Drain-to-Source On-Resistance | —    | 6.9   | 8.5  | mΩ    | $V_{GS} = 10V, I_D = 14A$ ③   |
|                              |                                      | —    | 10.6  | 12.5 |       | $V_{GS} = 4.5V, I_D = 11A$ ③  |
| $V_{GS(th)}$                 | Gate Threshold Voltage               | 1.35 | —     | 2.35 | V     | $V_{DS} = V_{GS}, I_D = 25\mu A$  |
| $\Delta V_{GS(th)}$          | Gate Threshold Voltage Coefficient   | —    | -6.2  | —    | mV/°C |   |
| $I_{DSS}$                    | Drain-to-Source Leakage Current      | —    | —     | 1.0  | μA    | $V_{DS} = 24V, V_{GS} = 0V$   |
|                              |                                      | —    | —     | 150  |       | $V_{DS} = 24V, V_{GS} = 0V, T_J = 125^\circ\text{C}$                              |
| $I_{GSS}$                    | Gate-to-Source Forward Leakage       | —    | —     | 100  | nA    | $V_{GS} = 20V$  |
|                              | Gate-to-Source Reverse Leakage       | —    | —     | -100 |       | $V_{GS} = -20V$   |
| gfs                          | Forward Transconductance             | 27   | —     | —    | S     | $V_{DS} = 15V, I_D = 11A$   |
| $Q_g$                        | Total Gate Charge                    | —    | 8.3   | 12   | nC    | $V_{DS} = 15V$<br>$V_{GS} = 4.5V$<br>$I_D = 11A$<br>See Fig. 16a and 16b          |
| $Q_{gs1}$                    | Pre-Vth Gate-to-Source Charge        | —    | 2.0   | —    |       |   |
| $Q_{gs2}$                    | Post-Vth Gate-to-Source Charge       | —    | 1.0   | —    |       |   |
| $Q_{gd}$                     | Gate-to-Drain Charge                 | —    | 3.2   | —    |       |   |
| $Q_{godr}$                   | Gate Charge Overdrive                | —    | 2.0   | —    |       |   |
| $Q_{sw}$                     | Switch Charge ( $Q_{gs2} + Q_{gd}$ ) | —    | 4.2   | —    |       |   |
| $Q_{oss}$                    | Output Charge                        | —    | 5.0   | —    | nC    | $V_{DS} = 16V, V_{GS} = 0V$   |
| $R_G$                        | Gate Resistance                      | —    | 1.8   | 3.0  | Ω     |   |
| $t_{d(on)}$                  | Turn-On Delay Time                   | —    | 8.2   | —    | ns    | $V_{DD} = 15V, V_{GS} = 4.5V$<br>$I_D = 11A$<br>$R_G = 1.8\Omega$<br>See Fig. 15a |
| $t_r$                        | Rise Time                            | —    | 11    | —    |       |   |
| $t_{d(off)}$                 | Turn-Off Delay Time                  | —    | 8.1   | —    |       |   |
| $t_f$                        | Fall Time                            | —    | 7.0   | —    |       |   |
| $C_{iss}$                    | Input Capacitance                    | —    | 1040  | —    | pF    | $V_{GS} = 0V$<br>$V_{DS} = 15V$<br>$f = 1.0MHz$                                   |
| $C_{oss}$                    | Output Capacitance                   | —    | 229   | —    |       |   |
| $C_{riss}$                   | Reverse Transfer Capacitance         | —    | 114   | —    |       |   |

## Avalanche Characteristics

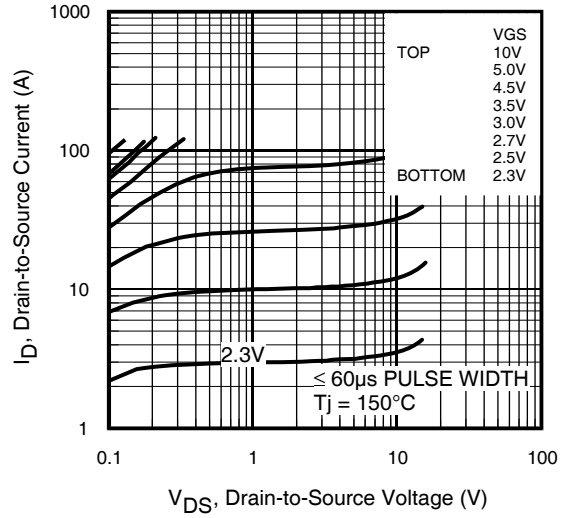
|          | Parameter                       | Typ. | Max. | Units |
|----------|---------------------------------|------|------|-------|
| $E_{AS}$ | Single Pulse Avalanche Energy ② | —    | 68   | mJ    |
| $I_{AR}$ | Avalanche Current ①             | —    | 11   | A     |

## Diode Characteristics

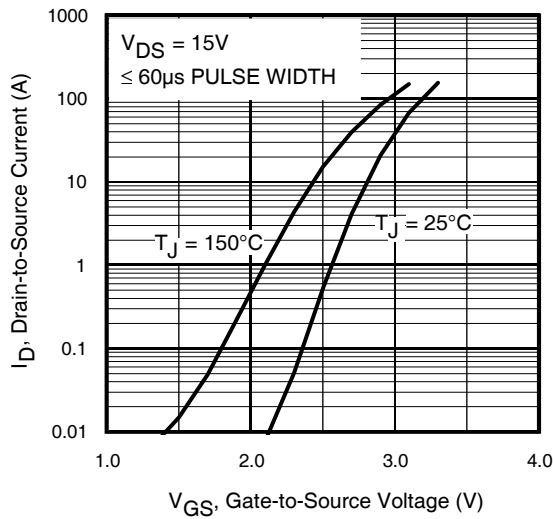
|          | Parameter                                 | Min.   | Typ. | Max. | Units | Conditions  |
|----------|---|--|------|------|-------|---|
| $I_S$    | Continuous Source Current<br>(Body Diode) | —  | —    | 3.1  | A     | MOSFET symbol<br>showing the<br>integral reverse<br>p-n junction diode. |
| $I_{SM}$ | Pulsed Source Current<br>(Body Diode) ①   | —  | —    | 112  |       |   |
| $V_{SD}$ | Diode Forward Voltage                     | —  | —    | 1.0  | V     | $T_J = 25^\circ\text{C}, I_S = 11A, V_{GS} = 0V$ ③                      |
| $t_{rr}$ | Reverse Recovery Time                     | —  | 14   | 21   | ns    | $T_J = 25^\circ\text{C}, I_F = 11A, V_{DD} = 15V$                       |
| $Q_{rr}$ | Reverse Recovery Charge                   | —  | 15   | 23   | nC    | $di/dt = 300A/\mu s$ ③  |
| $t_{on}$ | Forward Turn-On Time                      | Intrinsic turn-on time is negligible (turn-on is dominated by LS+LD) |      |      |       |   |



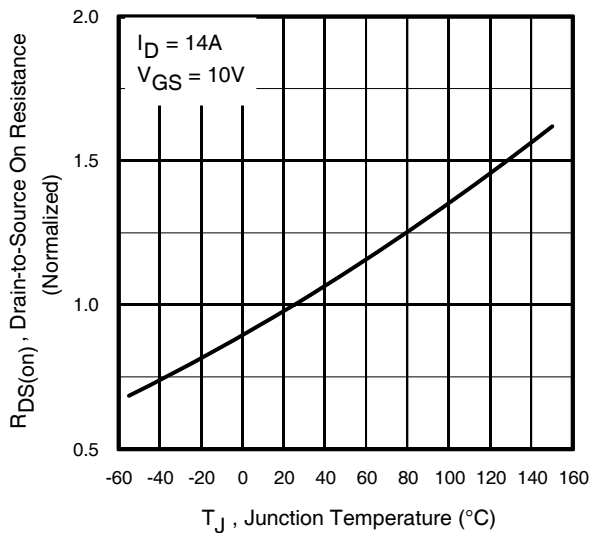
**Fig 1.** Typical Output Characteristics



**Fig 2.** Typical Output Characteristics

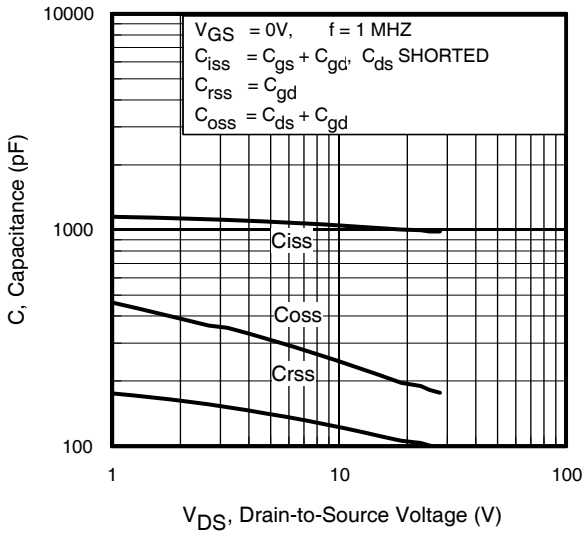


**Fig 3.** Typical Transfer Characteristics

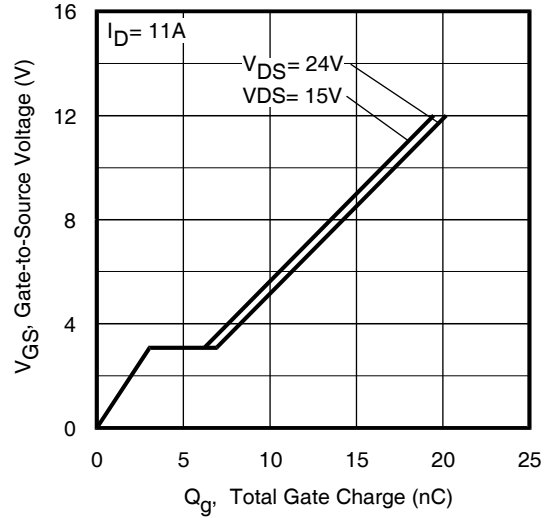


**Fig 4.** Normalized On-Resistance Vs. Temperature

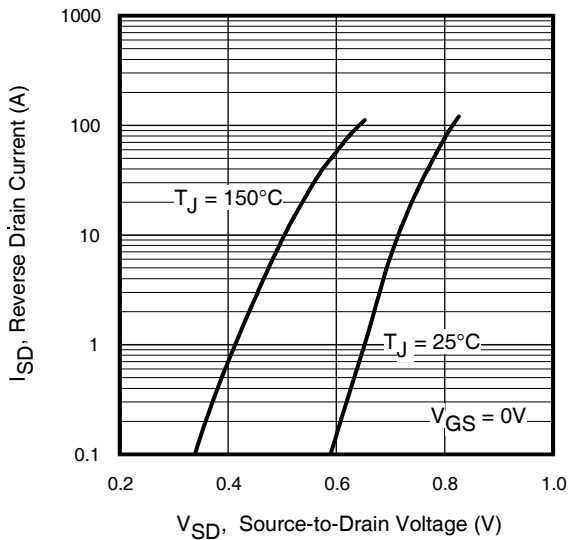
# IRF8721PbF



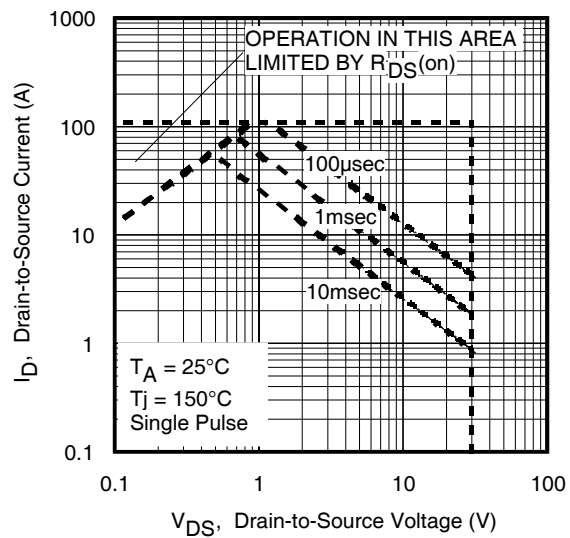
**Fig 5.** Typical Capacitance Vs. Drain-to-Source Voltage



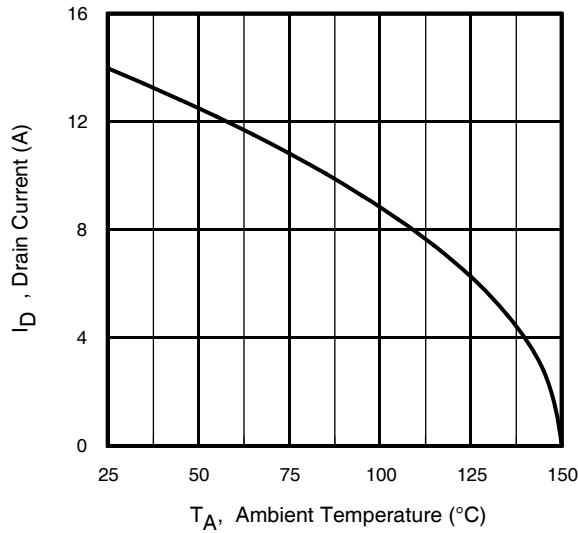
**Fig 6.** Typical Gate Charge Vs. Gate-to-Source Voltage



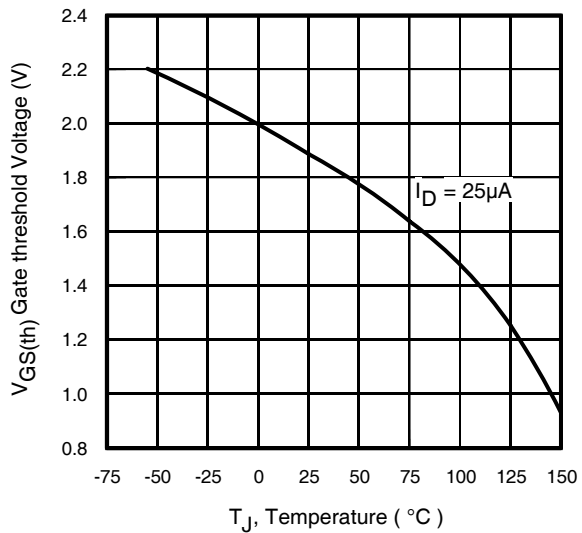
**Fig 7.** Typical Source-Drain Diode Forward Voltage



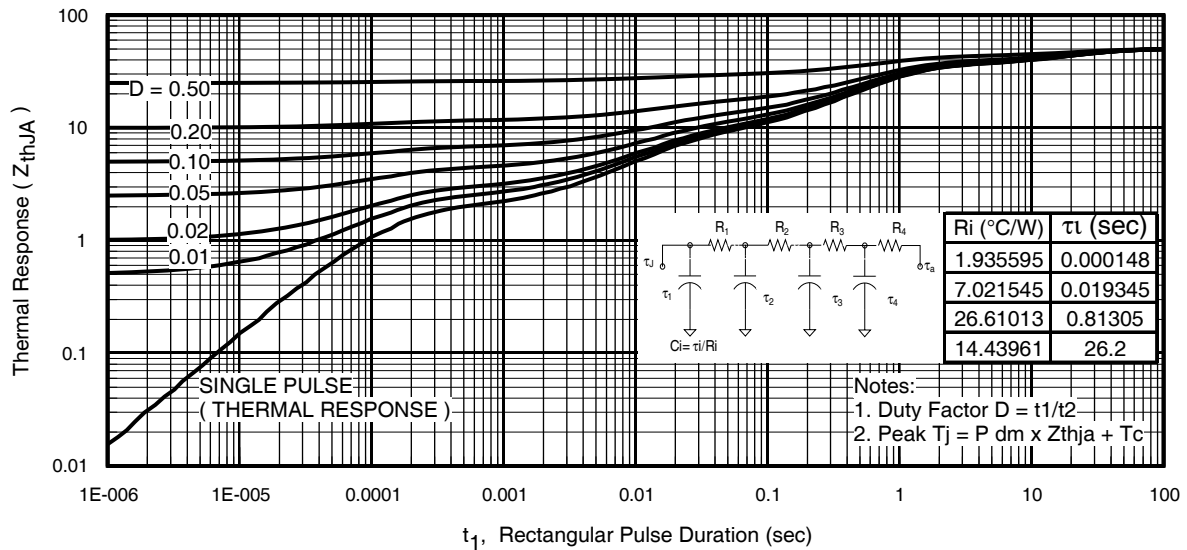
**Fig 8.** Maximum Safe Operating Area



**Fig 9.** Maximum Drain Current Vs. Case Temperature



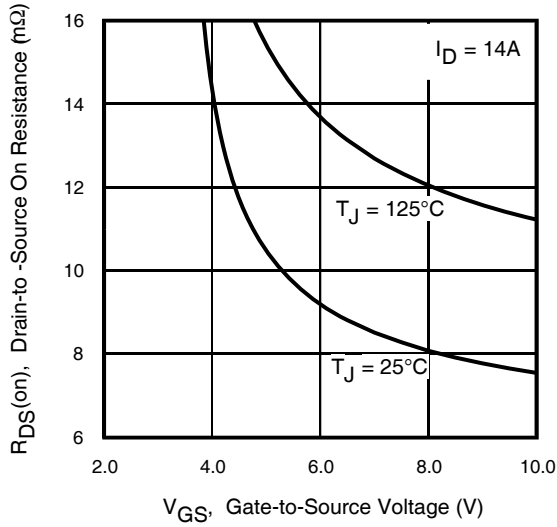
**Fig 10.** Threshold Voltage Vs. Temperature



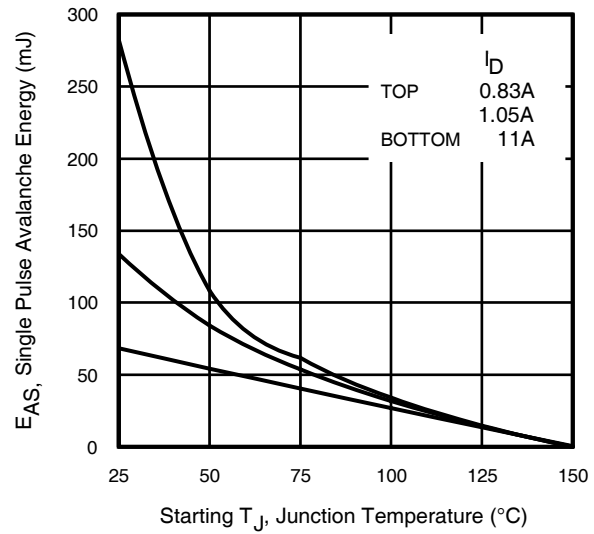
**Fig 11.** Maximum Effective Transient Thermal Impedance, Junction-to-Ambient

# IRF8721PbF

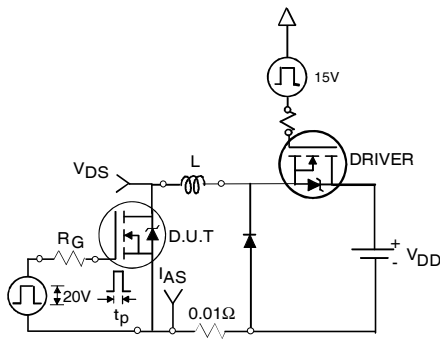
International  
**IR** Rectifier



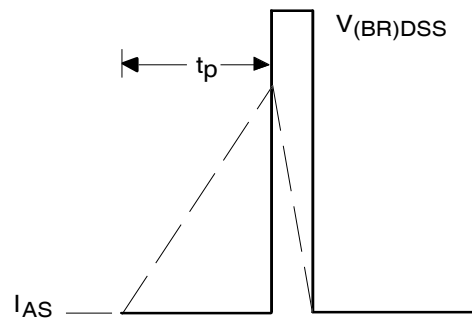
**Fig 12.** On-Resistance vs. Gate Voltage



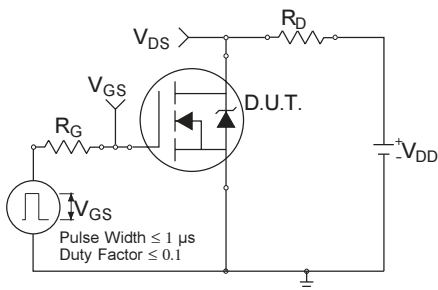
**Fig 13.** Maximum Avalanche Energy vs. Drain Current



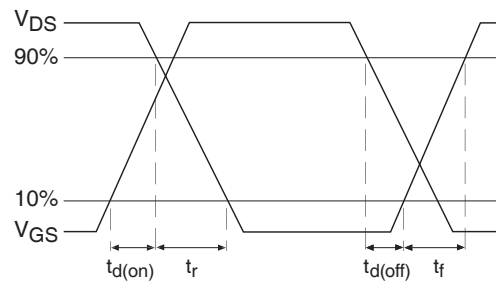
**Fig 14a.** Unclamped Inductive Test Circuit



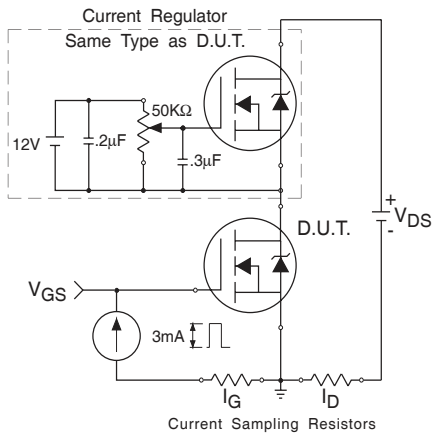
**Fig 14b.** Unclamped Inductive Waveforms



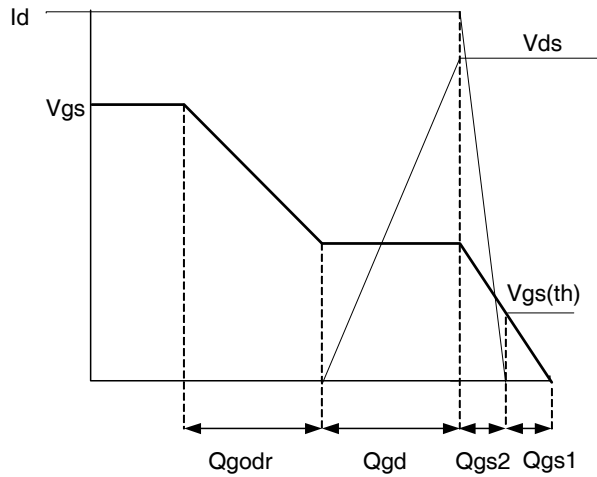
**Fig 15a.** Switching Time Test Circuit



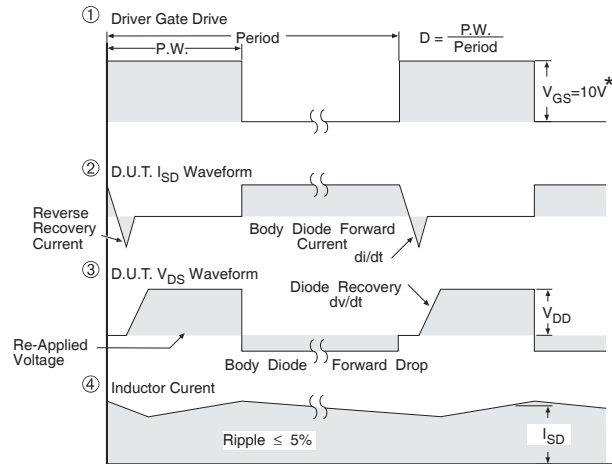
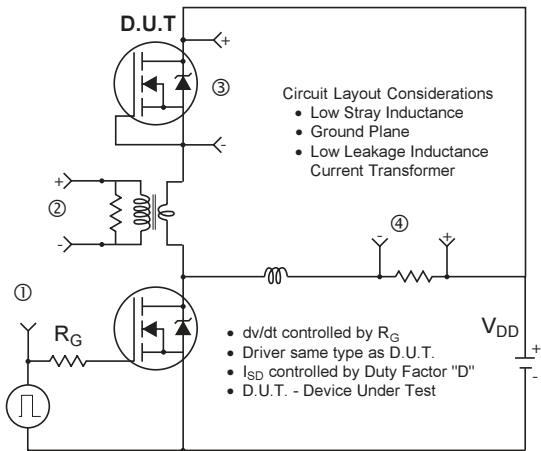
**Fig 15b.** Switching Time Waveforms



**Fig 16a.** Gate Charge Test Circuit



**Fig 16b.** Gate Charge Waveform



\*  $V_{GS} = 5V$  for Logic Level Devices

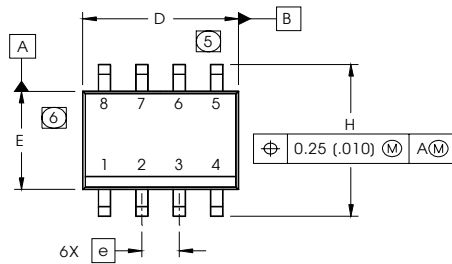
**Fig 17.** Peak Diode Recovery  $dv/dt$  Test Circuit for N-Channel  
HEXFET® Power MOSFETs

# IRF8721PbF

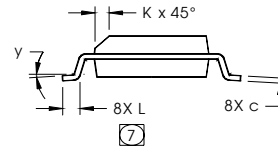
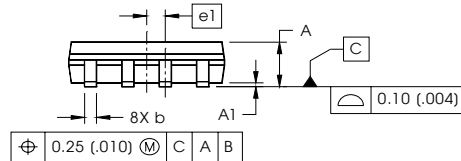
International  
**IR** Rectifier

## SO-8 Package Outline

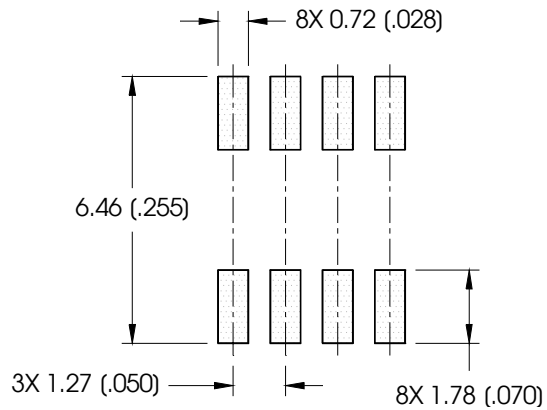
Dimensions are shown in millimeters (inches)



| DIM | INCHES     |       | MILLIMETERS |      |
|-----|------------|-------|-------------|------|
|     | MIN        | MAX   | MIN         | MAX  |
| A   | .0532      | .0688 | 1.35        | 1.75 |
| A1  | .0040      | .0098 | 0.10        | 0.25 |
| b   | .013       | .020  | 0.33        | 0.51 |
| c   | .0075      | .0098 | 0.19        | 0.25 |
| D   | .189       | .1968 | 4.80        | 5.00 |
| E   | .1497      | .1574 | 3.80        | 4.00 |
| e   | .050 BASIC |       | 1.27 BASIC  |      |
| e1  | .025 BASIC |       | 0.635 BASIC |      |
| H   | .2284      | .2440 | 5.80        | 6.20 |
| K   | .0099      | .0196 | 0.25        | 0.50 |
| L   | .016       | .050  | 0.40        | 1.27 |
| y   | 0°         | 8°    | 0°          | 8°   |



### FOOTPRINT

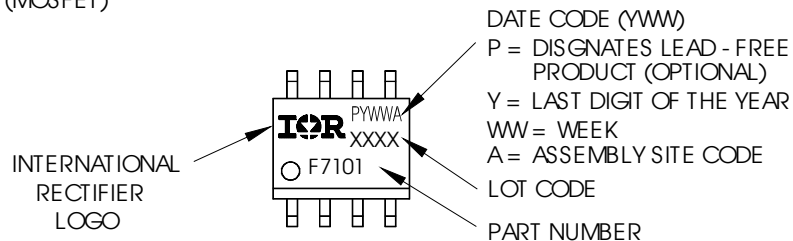


#### NOTES:

1. DIMENSIONING & TOLERANCING PER ASME Y14.5M-1994.
2. CONTROLLING DIMENSION: MILLIMETER
3. DIMENSIONS ARE SHOWN IN MILLIMETERS (INCHES).
4. OUTLINE CONFORMS TO JEDEC OUTLINE MS-012AA.
- ⑤ DIMENSION DOES NOT INCLUDE MOLD PROTRUSIONS. MOLD PROTRUSIONS NOT TO EXCEED 0.15 (.006).
- ⑥ DIMENSION DOES NOT INCLUDE MOLD PROTRUSIONS. MOLD PROTRUSIONS NOT TO EXCEED 0.25 (.010).
- ⑦ DIMENSION IS THE LENGTH OF LEAD FOR SOLDERING TO A SUBSTRATE.

## SO-8 Part Marking Information

EXAMPLE: THIS IS AN IRF7101 (MOSFET)

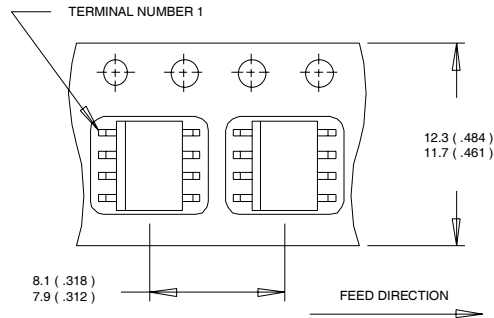


Note: For the most current drawing please refer to IR website at <http://www.irf.com/package/>

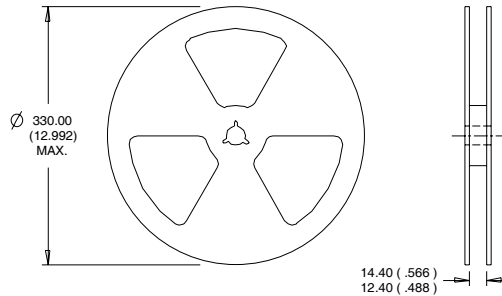


## SO-8 Tape and Reel

Dimensions are shown in millimeters (inches)



- NOTES:
1. CONTROLLING DIMENSION : MILLIMETER.
  2. ALL DIMENSIONS ARE SHOWN IN MILLIMETERS(INCHES).
  3. OUTLINE CONFORMS TO EIA-481 & EIA-541.



- NOTES:
1. CONTROLLING DIMENSION : MILLIMETER.
  2. OUTLINE CONFORMS TO EIA-481 & EIA-541.

**Note:** For the most current drawing please refer to IR website at <http://www.irf.com/package/>

**Notes:**

- ① Repetitive rating; pulse width limited by max. junction temperature.
- ② Starting  $T_J = 25^\circ\text{C}$ ,  $L = 1.09\text{mH}$ ,  $R_G = 25\Omega$ ,  $I_{AS} = 11\text{A}$ .
- ③ Pulse width  $\leq 400\mu\text{s}$ ; duty cycle  $\leq 2\%$ .
- ④ When mounted on 1 inch square copper board.
- ⑤  $R_{\theta}$  is measured at  $T_J$  of approximately  $90^\circ\text{C}$ .

Data and specifications subject to change without notice.  
 This product has been designed and qualified for the Consumer market.  
 Qualification Standards can be found on IR's Web site.

## **IMPORTANT NOTICE**

The information given in this document shall in no event be regarded as a guarantee of conditions or characteristics ("Beschaffheitsgarantie").

With respect to any examples, hints or any typical values stated herein and/or any information regarding the application of the product, Infineon Technologies hereby disclaims any and all warranties and liabilities of any kind, including without limitation warranties of non-infringement of intellectual property rights of any third party.

In addition, any information given in this document is subject to customer's compliance with its obligations stated in this document and any applicable legal requirements, norms and standards concerning customer's products and any use of the product of Infineon Technologies in customer's applications.

The data contained in this document is exclusively intended for technically trained staff. It is the responsibility of customer's technical departments to evaluate the suitability of the product for the intended application and the completeness of the product information given in this document with respect to such application.

For further information on the product, technology, delivery terms and conditions and prices please contact your nearest Infineon Technologies office ([www.infineon.com](http://www.infineon.com)).

## **WARNINGS**

Due to technical requirements products may contain dangerous substances. For information on the types in question please contact your nearest Infineon Technologies office.

Except as otherwise explicitly approved by Infineon Technologies in a written document signed by authorized representatives of Infineon Technologies, Infineon Technologies' products may not be used in any applications where a failure of the product or any consequences of the use thereof can reasonably be expected to result in personal injury.