

### Features

- DAC 80 ALTERNATE SOURCE
- MONOLITHIC CONSTRUCTION (SINGLE CHIP)
- FAST SETTLING
- GUARANTEED MONOTONIC 0°C to 75°C
- WAFER LASER TRIMMED
- APPLICATIONS RESISTORS ON-CHIP
- ON-BOARD REFERENCE
- DIELECTRIC ISOLATION (DI) PROCESSING
- $\pm 12\text{V}$  POWER SUPPLY OPERATION

### Applications

- HIGH SPEED A/D CONVERTERS
- PRECISION INSTRUMENTATION
- CRT DISPLAY GENERATION

### Description

The HI-5680 is a monolithic, direct replacement for the popular DAC80-CBI, DAC80Z-CBI, and DAC85C-CBI, incorporating the best features of each. Single chip construction, along with several design innovations, make the HI-5680 the optimum choice for low cost, high reliability applications.

Harris' unique Dielectric Isolation (DI) processing reduces internal parasitics, resulting in fast switching times and minimum glitch. On-board span resistors are provided for good tracking over temperature, and are laser trimmed to high accuracy. These may be used with the on-board op-amp (voltage output models; HI-5680V), or with a user supplied external amplifier (HI-5680I).

Internally, the HI-5680 eliminates code dependent ground currents by routing current from the positive supply to the internal ground node, as determined by an auxiliary R-2R ladder. This results in a cancellation of code dependent ground currents allowing virtually zero variation in current through the package common, pin 21.

The HI-5680 is available in both current and voltage output models which are guaranteed over the 0°C to +75°C temperature range. All models include a buried zener reference featuring low temperature coefficient. In addition, the voltage output models include an on-board output amplifier. Both versions operate with a +5V logic supply and a  $\pm V_S$  in the range of  $\pm(11.4\text{V to }16.5\text{V})$ .

### Pinouts

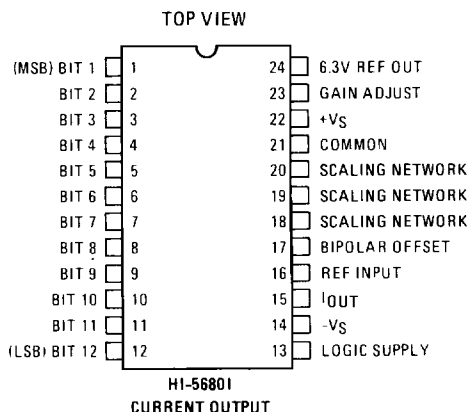
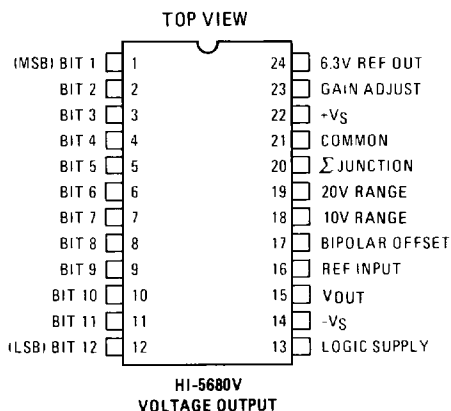

**Functional Diagram Voltage Output**

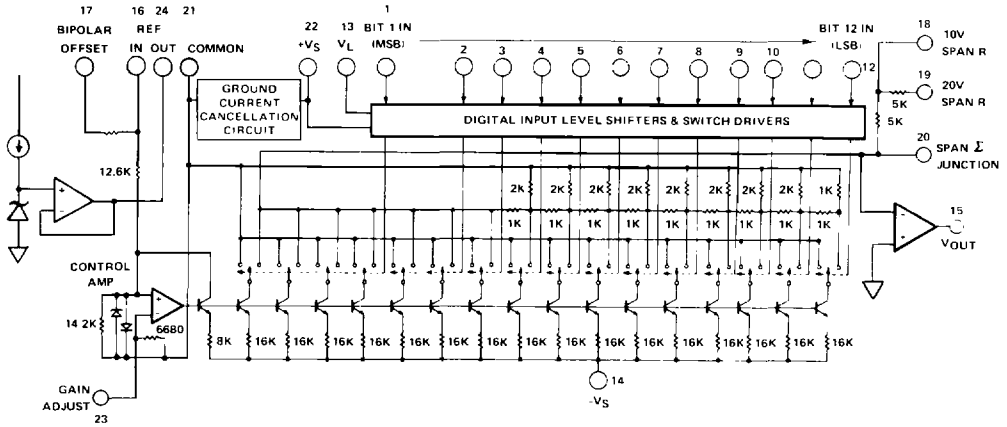

HI-5680 V

**Functional Diagram Current Output**

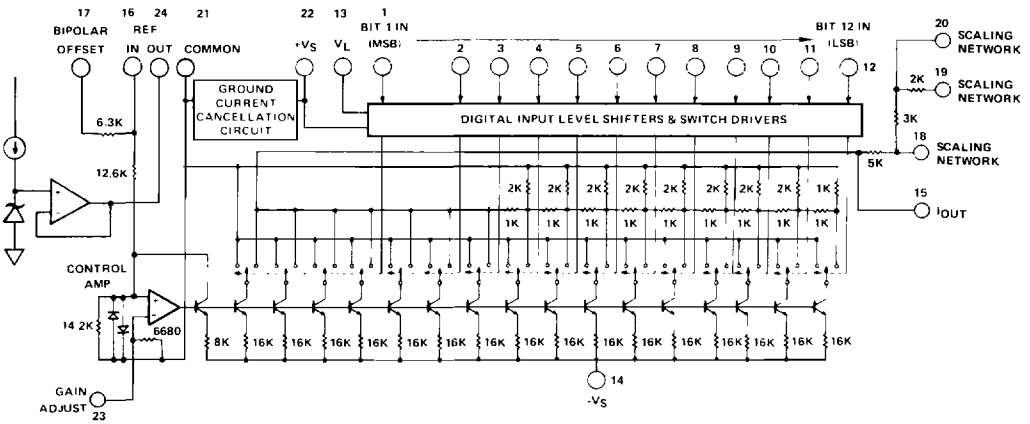

HI-5680 I

# Specifications HI-5680

HI-5680

## Absolute Maximum Ratings (Note 1)

Power Supply Inputs	$+V_S$	+20V	Junction Temperature	175°C
	$-V_S$	-20V		
	$+V_{LOGIC}$	+20V		
Reference	Input (pin 16)	$+V_S$	Operating Temperature Range	HI-5680I/V-5 0°C to +75°C
	Output drain	2.5mA		
				Storage Temperature Range -65°C to +150°C
Digital Inputs	Bits 1 to 12	-1V to +12V		

## Electrical Specifications

( $T_A = +25^\circ\text{C}$ ,  $V_S = \pm 15\text{V}$ ,  $V_{LOGIC} = +5\text{V}$ , Pin 16 connected to Pin 24 unless otherwise specified.)

PARAMETER	CONDITIONS	HI-5680			UNITS
		MIN	TYP	MAX	
DIGITAL INPUT (3)					
Resolution				12	Bits
Logic Levels	TTL Compatible				
Logic "1"	at +1 $\mu\text{A}$	+2		+5.5	Volts
Logic "0"	at -100 $\mu\text{A}$	0		+0.8	Volts
ACCURACY (3)					
Linearity Error	0°C to +75°C		$\pm\frac{1}{4}$	$\pm\frac{1}{2}$	LSB
Differential Lin. Error	0°C to +75°C		$\pm\frac{1}{2}$	$\pm\frac{3}{4}$	LSB
Gain Error (2)			$\pm 0.1$	$\pm 0.3$	%FSR (4)
Offset Error (2)			$\pm 0.05$	$\pm 0.15$	%FSR
Monotonicity	0°C to +75°C		Guaranteed		
DRIFT (3)					
Total Bipolar Drift (Includes gain, offset and linearity drifts.)	0°C to +75°C			$\pm 20$	ppm/°C
Total Error	0°C to +75°C				
Unipolar (Note 6)			$\pm 0.08$	$\pm 0.15$	%FSR
Bipolar (Note 6)			$\pm 0.06$	$\pm 1$	%FSR
Gain	Including internal reference		$\pm 15$	$\pm 30$	ppm/°C
	Exclusive of internal reference		$\pm 5$	$\pm 7$	ppm/°C
Unipolar Offset			$\pm 1$	$\pm 3$	ppm/°C
Bipolar Offset			$\pm 5$	$\pm 10$	ppm/°C
CONVERSION SPEED (3)					
Voltage Models					
Settling time (3)	to $\pm 0.01\%$ of FSR for FSR Change				
With 10k $\Omega$ Feedback			3		$\mu\text{s}$
With 5k $\Omega$ Feedback			1.5		$\mu\text{s}$
For 1 LSB change			1.5		$\mu\text{s}$
Slew Rate		10	15		V/ $\mu\text{s}$
Current Models					
Settling time (3)	to $\pm 0.01\%$ of FSR for FSR Change				
10 to 100 $\Omega$ load			300		ns
1k $\Omega$ load			1000		ns
ANALOG OUTPUT					
Voltage Models					
Output current		$\pm 5$			mA
Output Resistance			.05		$\Omega$
Short Circuit Duration	to common		continuous		

6

D-TO-A  
CONVERTERS

## Specifications HI-5680

PARAMETER	CONDITIONS	HI-5680X			UNITS
		MIN	TYP	MAX	
<b>ANALOG OUTPUT</b>					
Current Models					
Output Current					
Unipolar		-1.6	-2	-2.4	mA
Bipolar		± 0.8	± 1	± 1.2	mA
Output Resistance					
Unipolar			2.0		kΩ
Bipolar			2.0		kΩ
Compliance Limit (3)		-2.5		+10	V
<b>INTERNAL REFERENCE</b>					
Output Voltage		+6.174	+6.3	+6.426	V
Output Impedance			1.5		Ω
External Current				+2.5	mA
Tempco of Drift			20		ppm/°C
<b>POWER SUPPLY SENSITIVITY (3)</b>					
+15V supply				.002	$\frac{\%FSR}{\Delta V_s}$
-15V supply				.002	
+5V supply				.002	
<b>POWER SUPPLY REQUIREMENTS (5)</b>					
Range					
+15V		+11.4	+15	+16.5	V
-15V		-11.4	-15	-16.5	V
+5V		+ 4.5	+ 5	+16.5	V
Current					
+15V			8	11	mA
-15V			-12	-20	mA
+5V			4.5	8	mA

### NOTES:

1. Absolute maximum ratings are limiting values, applied individually, beyond which the serviceability of the circuit may be impaired. Functional operation under any of these conditions is not necessarily implied.
2. Adjustable to zero using external potentiometers.
3. See definitions.
4. FSR is "Full Scale Range" and is 20V for ± 10V range, 10V for ± 5V range, etc., or 2mA (± 20%) for current output.
5. The HI-5680 will operate with supply voltages as low as ± 11.4V. It is recommended that output voltage range -10V to +10V not be used if the supply voltages are less than ± 12V.
6. With gain and offset errors adjusted to zero at 25°C.

### Die Characteristics

Transistor Count		259
Die Size:		210 x 125 mils
Thermal Constants:	$\theta_{ja}$	49°C/W
	$\theta_{jc}$	12°C/W
Tie Substrate to:		Ground
Process:		Bipolar - DI

## Definitions of Specifications

### DIGITAL INPUTS

The HI-5680 accepts digital input codes in complementary binary, complementary offset binary, and complementary two's complement binary.

DIGITAL INPUT	ANALOG OUTPUT		
	Complementary Binary	Complementary Offset Binary	Complementary Two's Complement *
MSB LSB			
000...000	+ Full Scale	+ Full Scale	-LSB
100...000	Mid Scale -1 LSB	-1 LSB	+ Full Scale
111...111	Zero	- Full Scale	Zero
011...111	+½ Full Scale	Zero	- Full Scale

\* Invert MSB with external inverter to obtain CTC Coding

### SETTLING TIME

That interval between application of a digital step input, and final entry of the analog output within a specified window about the settled value. Harris Semiconductor usually specifies a unipolar 10V or bipolar full scale step, to be measured from 50% of the input digital transition, and a window of  $\pm\frac{1}{2}$  LSB about the final value. The device output is then rated according to the worst (longest settling) case: low to high, or high to low.

### DRIFT

**GAIN DRIFT** – The change in full scale analog output over the specified temperature range expressed in parts per million of full scale per °C (ppm of FSR/°C). Gain error is measured with respect to +25°C at high ( $T_H$ ) and low ( $T_L$ ) temperatures. Gain drift is calculated for both high ( $T_H - 25^\circ\text{C}$ ) and low ranges (+25°C -  $T_L$ ) by dividing the gain error by the respective change in temperature. The specification is the larger of the two representing worst case drift.

**OFFSET DRIFT** – The change in analog output with all bits OFF over the specified temperature range expressed in parts per million of full scale range per °C (ppm of FSR/°C). Offset error is measured with respect to +25°C at high ( $T_H$ ) and low ( $T_L$ ) temperatures. Offset Drift is calculated for both high ( $T_H - 25^\circ\text{C}$ ) and low (+25°C -  $T_L$ ) ranges by dividing the offset error by the respective change in temperature. The specification given is the larger of the two, representing worst-case drift.

### ACCURACY

**INTEGRAL NONLINEARITY** – The maximum deviation of the actual transfer characteristic from an ideal straight line. The ideal line is positioned according to “end-point linearity” for D/A converter products from Harris Semiconductor, i.e. the line is drawn between the end-points of the actual transfer characteristic (codes 00...0 and 11...1).

**DIFFERENTIAL NONLINEARITY** – The difference between one LSB and the output voltage change corresponding to any two consecutive codes. A Differential Nonlinearity of  $\pm 1$  LSB or less guarantees monotonicity.

**MONOTONICITY** – The property of a D/A converter's transfer function which guarantees that the output derivative will not change sign in response to a sequence of increasing (or decreasing) input codes. That is, the only output response to a code change is to remain constant, increase for increasing code, or decrease for decreasing code.

### POWER SUPPLY SENSITIVITY

Power Supply Sensitivity is a measure of the change in gain and offset of the D/A converter resulting from a change in -15V, or +15V supplies. It is specified under DC conditions and expressed as parts per million of full scale range per percent of change in power supply (ppm of FSR/%).

### COMPLIANCE

Compliance Voltage is the maximum output voltage range that can be tolerated and still maintain its specified accuracy. Compliance Limit implies functional operation only and makes no claims to accuracy.

### GLITCH

A glitch on the output of a D/A converter is a transient spike resulting from unequal internal ON-OFF switching times. Worst case glitches usually occur at half-scale or the major carry code transition from 011...1 to 100...0 or vice versa. For example, if turn ON is greater than turn OFF for 011...1 to 100...0, an intermediate state of 000...0 exists, such that, the output momentarily glitches toward zero output. Matched switching times and fast switching will reduce glitches considerably. (Measured as one half the product of duration and amplitude.)

# Operating Instructions

## DECOUPLING AND GROUNDING

For best accuracy and high frequency performance, the grounding and decoupling scheme shown in Figure 1 should be used. Decoupling capacitors should be connected close to the HI-5680 (preferably to the device pins) and should be tantalum or electrolytic bypassed with ceramic types for best high frequency noise rejection.

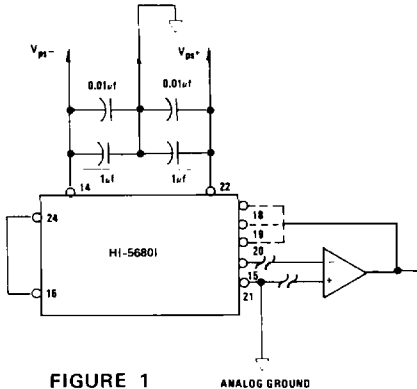

FIGURE 1 ANALOG GROUND

## REFERENCE SUPPLY

An internal 6.3Volt reference is provided on board all HI-5680 models. This voltage (pin 24) is accurate to  $\pm 2\%$  and must be connected to the reference input (pin 16) for specified operation. This reference may be used externally, provided current drain is limited to 2.5mA. An external buffer amplifier is recommended if this reference is to be used to drive other system components. Otherwise, variations in the load driven by the reference will result in gain variations of the HI-5680. All gain adjustments should be made under constant load conditions.

## VOLTAGE OUTPUT HI-5680V

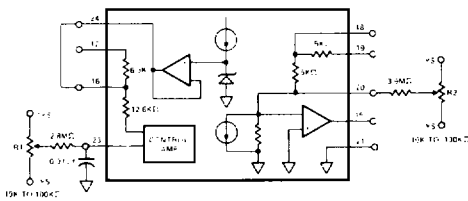

FIGURE 2

## RANGE CONNECTIONS

	RANGE	CONNECT		
		PIN 15	PIN 17	PIN 19
Unipolar	0 to +5V	18	N.C.	20
	0 to +10V	18	N.C.	N.C.
Bipolar	$\pm 2.5V$	18	20	20
	$\pm 5V$	18	20	N.C.
	$\pm 10V$	19	20	15

## CURRENT OUTPUT HI-5680I

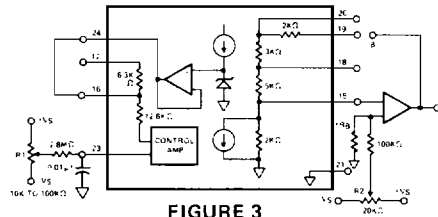

FIGURE 3

$R_2$  should equal the DAC's output resistance, which is  $2K\Omega // R_{FEEDBACK}$ .

## EXTERNAL AMPLIFIER CONNECTIONS

To use the HI-5680I with an external amplifier, connect as follows:

RANGE	PIN 17 to	PIN 18 to	PIN 19 to	PIN 20 to
0 to +10V	N.C.	B	18*	19*
0 to +5V	N.C.	B	15	N.C.
$\pm 10V$	15	N.C.	B	N.C.
$\pm 5V$	15	B	18*	19*
$\pm 2.5V$	15	B	15	N.C.

\*these connections help reduce stray capacitance in the feedback loop.

## GAIN AND OFFSET CALIBRATION

(Applies to Figure 2 and 3.)

### UNIPOLAR CALIBRATION

#### Step 1: Offset

Turn all bits OFF (11...1)  
Adjust  $R_2$  for zero volts out

#### Step 2: Gain

Turn all bits ON (00...0)  
Adjust  $R_1$  for FS-1LSB  
That is:  
4.9988 for 0 to +5V range  
9.9976 for 0 to +10V range

### BIPOLAR CALIBRATION

#### Step 1: Offset

Turn all bits OFF (11...1)  
Adjust  $R_2$  for Negative FS  
That is:  
-10V for  $\pm 10V$  range  
-5V for  $\pm 5V$  range  
-2.5V for  $\pm 2.5V$  range

#### Step 2: Gain

Turn all bits ON (00...0)  
Adjust  $R_1$  for positive FS-1LSB  
That is:  
+9.9951V for  $\pm 10V$  range  
+4.9976V for  $\pm 5V$  range  
+2.4988V for  $\pm 2.5V$  range

This Bipolar procedure adjusts the output range end points. The maximum error at zero (half scale) will not exceed the Linearity error. See the "Accuracy" specifications.