

# PIC32 Audio Codec Daughter Board – AK4642EN Information Sheet

Thank you for purchasing a PIC32 Audio Codec Daughter Board – AK4642EN. This information sheet provides important information that will help you successfully use the daughter board as quickly as possible.

This daughter board is designed specifically to be used with the PIC32 Bluetooth® Audio Development Kit (DV320032); however, it can also be used with other Microchip development hardware.

For more information about this daughter board, please visit: <http://www.microchip.com>.

## Features

The PIC32 Audio Codec Daughter Board – AK4642EN is a high-performance stereo codec board for selected PIC32 hardware development platforms. This board features the AKM AK4642EN stereo codec, which includes built-in microphone and headphone amplifiers. This board is suitable for adding audio input and output capabilities to the PIC32 Bluetooth Starter Kit, and as previously mentioned, it is compatible with the PIC32 Bluetooth Audio Development Kit.

The PIC32 Audio Codec Daughter Board – AK4642EN features include:

- AK4642EN Codec
- MCP1801 Power Regulator
- On-board MEMs Microphone
- 3.5 mm Inputs and Outputs:
  - Line in
  - External Mic in
  - Line out
  - Headphone out

## Additional Information

For more information on drivers and examples, please visit:

- [www.microchip.com/pic32btsuites](http://www.microchip.com/pic32btsuites)
- [www.microchip.com/harmony](http://www.microchip.com/harmony)

### Americas

Atlanta - 678-957-9614  
Austin - 512-257-3370  
Boston - 774-760-0087  
Chicago - 630-285-0071  
Cleveland - 216-447-0464  
Dallas - 972-818-7423  
Detroit - 248-848-4000  
Houston - 281-894-5983  
Indianapolis - 317-773-8323  
Los Angeles - 949-462-9523  
New York - 631-435-6000  
Phoenix - 480-792-7200  
Santa Clara - 408-961-6444  
Toronto - 905-673-0699

### Europe

Austria - Wels - 43-7242-2244-39  
Denmark - Copenhagen - 45-4450-2828  
France - Paris - 33-1-69-53-63-20  
Germany - Munich - 49-89-627-144-0  
Italy - Milan - 39-0331-742611  
Netherlands - Drunen - 31-416-690399  
Spain - Madrid - 34-91-708-08-90  
UK - Wokingham - 44-118-921-5869

### Asia/Pacific

Australia - Sydney - 61-2-9868-6733  
China - Beijing - 86-10-8569-2100

### Asia/Pacific (Continued)

China - Chengdu - 86-28-8665-5511  
China - Chongqing - 86-23-8980-9588  
China - Hangzhou - 86-571-8792-8115  
China - Hong Kong SAR - 852-2943-5100  
China - Nanjing - 86-25-8473-2460  
China - Qingdao - 86-532-8502-7355  
China - Shanghai - 86-21-5407-5533  
China - Shenyang - 86-24-2334-2829  
China - Shenzhen - 86-755-8864-2200  
China - Wuhan - 86-27-5980-5300  
China - Xiamen - 86-592-2388138  
China - Xian - 86-29-8833-7252  
China - Zhuhai - 86-756-3210040  
India - Bangalore - 91-80-3090-4444  
India - New Delhi - 91-11-4160-8631  
India - Pune - 91-20-3019-1500  
Japan - Osaka - 81-6-6152-7160  
Japan - Tokyo - 81-3-6880-3770  
Korea - Daegu - 82-53-744-4301  
Korea - Seoul - 82-2-554-7200  
Malaysia - Kuala Lumpur - 60-3-6201-9857  
Malaysia - Penang - 60-4-227-8870  
Philippines - Manila - 63-2-634-9065  
Singapore - 65-6334-8870  
Taiwan - Hsin Chu - 886-3-5778-366  
Taiwan - Kaohsiung - 886-7-213-7840  
Taiwan - Taipei - 886-2-2508-8600  
Thailand - Bangkok - 66-2-694-1351

03/25/14



Microchip Technology Inc. • 2355 West Chandler Blvd. • Chandler, AZ 85224-6199

[www.microchip.com](http://www.microchip.com)

The Microchip name and logo, the Microchip logo, and MPLAB are registered trademarks of Microchip Technology Incorporated in the U.S.A. and other countries. All other trademarks mentioned herein are property of their respective companies. © 2014, Microchip Technology Incorporated, Printed in the U.S.A. All Rights Reserved. 03/14

DS50002318A



# PIC32 AK4642EN Daughter Board Information Sheet

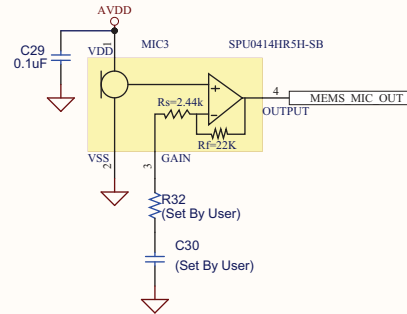
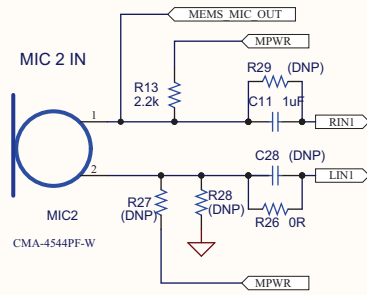
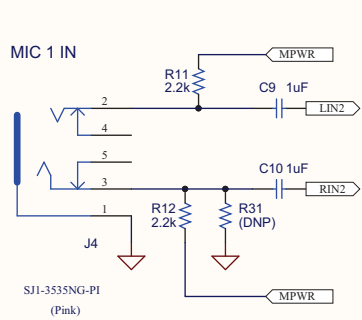
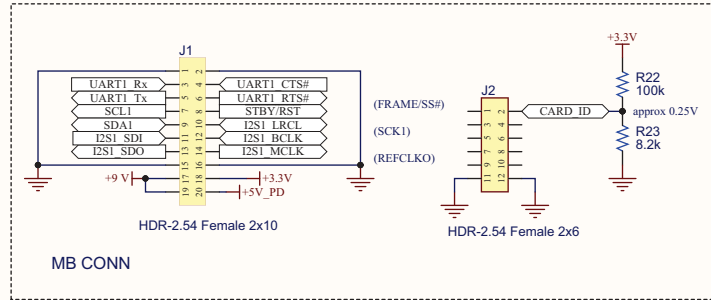
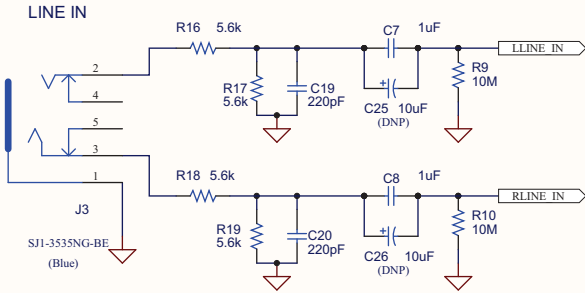

J8 Jumper Positions	
MIC 1 IN Selected	LINE IN Selected
pins 1,3: Shorted	pins 3,5: Shorted
pins 2,4: Shorted	pins 4,6: Shorted
pins 5,6: N/C	pins 1,2: N/C

