

PVD Series Parts Verification Sensor



Datasheet

Diffuse or retroreflective sensor for error proofing of bin-picking operations



- One-component system, easy to mount and even easier to use. Automatically operates in either diffuse or retroreflective mode, depending on the application
- Automatic setup and adjustment; wide beam pattern provides easy alignment
- Range up to 2 m (6.5 ft) when used with retroreflective target; 400 mm (15.7 in) when used in diffuse mode
- Large job lights on either side of the metal housing can be remotely controlled to initiate user action with a solid or a blinking green light; job lights turn red to indicate bin-picking errors
- Compact package size; only 30 mm wide x 15 mm deep (1.2 in x 0.6 in)
- Available in 2 lengths to fit existing parts bin sizes and configurations
- Easy DIP-switch adjustments: PNP/NPN output, normally open/normally closed operation, solid/flashing job light, and gate polarity for job light activation
- Two LEDs indicate power ON and output ON
- Choose 2 m (6.5 ft) unterminated cable or 2 m (6.5 ft) cable with 5-pin Euro-style quick-disconnect connector
- Heavy-duty protective brackets available
- 12 V DC to 30 V DC operation



WARNING:

- **Do not use this device for personnel protection**
- Using this device for personnel protection could result in serious injury or death.
- This device does not include the self-checking redundant circuitry necessary to allow its use in personnel safety applications. A device failure or malfunction can cause either an energized (on) or de-energized (off) output condition.

Models

Models ¹	Range	Array	Cable	Sensing Beam	Supply Voltage	Output
PVD100	Retroreflective Mode: up to 2 m (6.5 ft) Diffuse Mode: up to 400 mm (15.7 in)	100 mm (4 in) long, 4 beams	2 m (6.5 ft) 5-wire cable, unterminated	Visible red, 630 nm	12 V DC to 30 V DC	User-selectable NPN/PNP
PVD100Q			2 m (6.5 ft) cable, terminated in a quick disconnect connector			
PVD225	All models may be used in either sensing mode.	225 mm (9 in) long, 8 beams	2 m (6.5 ft) 5-wire cable, unterminated			
PVD225Q			2 m (6.5 ft) cable, terminated in a quick disconnect connector			

Overview

The PVD Series Parts Verification Sensor is a one-component, easy-to-use light screen suited to many part assembly, bin picking (pick-to-light), and error-proofing applications. The PVD increases task efficiency due to simplified job training, increased quality control (no skipped components), and reduced rework and inspections. It speeds the resumption of work after breaks and other distractions, and is ideal for multilingual workplaces where communication is an issue.

The PVD self-contained, solid-state emitter/receiver array is capable of functioning in either diffuse or retroreflective sensing mode. No configuration is required for this selection. If a retroreflective target is installed opposite the sensor, it will function in retroreflective mode. If not, it will function in diffuse mode. The sensor's ongoing self-adjustment feature requires no user adjustment; the sensor adapts to the sensing conditions after 15 seconds when blocked. Sensor range decreases when no retroreflector is installed.

The DIP-switch-selectable PNP/NPN output interfaces to a system controller, which is pre-programmed for a specific sequence of tasks. Mounted with its visible red beams stretching across each parts bin, the sensor job light signals the assembler which bins contain items to be picked in a given operation and in what order they should be picked.

As the assembler takes a part in sequence and breaks the beam, the sensor senses that the part was removed and it sends an output signal to the controller. The controller then verifies if the correct part was taken and may respond by turning that job light OFF, activating the job light of the next bin in the sequence. If the assembler reaches into a bin out of sequence, the PVD turns on its output to signal the system controller and turns on its red job light to signal the assembler that an incorrect pick has occurred.

Standard configuration options are selected by means of a bank of four DIP switches behind a press-on black rubber cover. DIP switch options include: PNP or NPN output, Normally Open or Normally Closed operation, steady or flashing job light, and job light control input.

Using specialized Banner software, additional configuration options can be adjusted. These options are programmed via the gray Datacom wire. Consult the factory or your Banner sales representative for more information. These additional options include: operating frequency, channel blanking, automatic update rates, ON and OFF delays, and customized job light configurations.

¹

- To order the 9 m (30 ft) PVC cable model, add the suffix "W/30" to the cabled model number. For example, PVD100 W/30.
- To order the 150 mm (6 in) PVC cable model with a quick disconnect, add the suffix "W/6IN" to the cabled model number. For example, PVD100Q W/6IN.
- Models with a quick disconnect require a mating cordset.



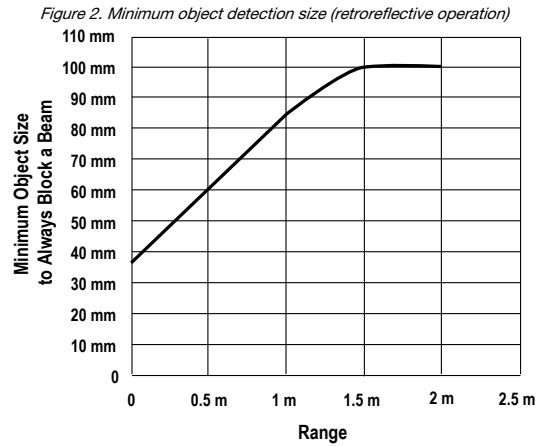
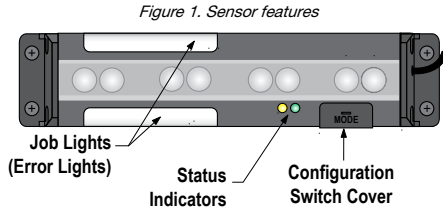

Configuration

To configure the PVD, set the DIP switches as shown, using the supplied plastic screwdriver to avoid damaging the switches or causing a short circuit.

Cover Removal	Cover Replacement
<p>Insert a fingernail or small screwdriver into the slot; apply gentle pressure, angling away from the sensor lens. The cover will remain tethered to the sensor housing.</p>	<p>To replace the switch cover, align one edge of the cover with the edge of the sensor housing opening. Then press the front corners into place.</p>

The switches determine four status operating modes:

PVD Configuration DIP Switch Settings									
The factory default setting is ON for all switches	Switch Condition								
<p><i>Figure 3. Configuration DIP switch setting positions</i></p> <p>ON Example Shown: ↑ Switch #1 OFF ↓ Switch #2 ON ↓ Switch #3 OFF OFF Switch #4 ON</p>	<table border="1"> <tr> <td>1</td> <td>ON = PNP output OFF = NPN output</td> </tr> <tr> <td>2</td> <td>ON = Normally Open OFF = Normally Closed</td> </tr> <tr> <td>3</td> <td>ON = Job light steady OFF = Job light flashes</td> </tr> <tr> <td>4</td> <td> Job light control input: Connect the white wire as follows: PNP Output ON = Job light ON for +10 to 30V dc (29kΩ input impedance) OFF = Job light ON for 0 to 1.5V dc/open circuit NPN Output ON = Job light ON for +10 to 30V dc/open circuit OFF = Job light ON for 0 to 1.5V dc (10kΩ input impedance) </td> </tr> </table>	1	ON = PNP output OFF = NPN output	2	ON = Normally Open OFF = Normally Closed	3	ON = Job light steady OFF = Job light flashes	4	Job light control input: Connect the white wire as follows: PNP Output ON = Job light ON for +10 to 30V dc (29kΩ input impedance) OFF = Job light ON for 0 to 1.5V dc/open circuit NPN Output ON = Job light ON for +10 to 30V dc/open circuit OFF = Job light ON for 0 to 1.5V dc (10kΩ input impedance)
1	ON = PNP output OFF = NPN output								
2	ON = Normally Open OFF = Normally Closed								
3	ON = Job light steady OFF = Job light flashes								
4	Job light control input: Connect the white wire as follows: PNP Output ON = Job light ON for +10 to 30V dc (29kΩ input impedance) OFF = Job light ON for 0 to 1.5V dc/open circuit NPN Output ON = Job light ON for +10 to 30V dc/open circuit OFF = Job light ON for 0 to 1.5V dc (10kΩ input impedance)								

Wiring

All models feature integral 2 m (6.5 ft) long, 3.3 mm (0.13 inch) diameter PVC-jacketed cables. Models whose model numbers end in "Q" are terminated with quick-disconnect (QD) Euro-style 5-pin connectors; other models have unterminated ends. Optional mating QD cables are available. Either 4-pin or 5-pin QD cables may be used; the center pin of a 5-pin cable (gray wire, pin 5) is unused in normal operation.

Wiring is functionally identical for cabled and quick-disconnect models.

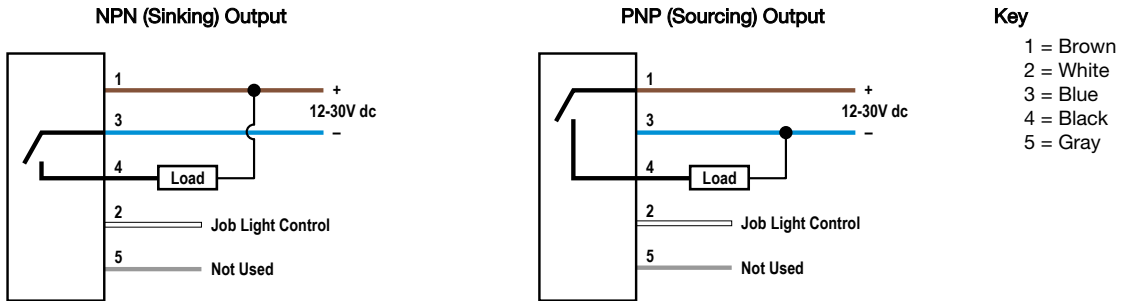

See [Configuration](#) on p. 2 for job light control input requirements.

Status Indicators/Troubleshooting

Indicator	Condition	Description	Status Indicators
#1	Steady Yellow	Output is active (Changing Switch #2 to N.C. turns the yellow indicator ON when the system is clear)	<p>Status Indicator #1</p> <p>Status Indicator #2</p>
	OFF	Output is inactive (Changing Switch #2 to N.O. turns the yellow indicator ON when the system is blocked)	
#2	Steady Green	Power is ON and system is OK	
	Flashing Green	Blanking is enabled	
	OFF	Power is OFF	

Installation

Multiple sensors located farther than the sensor's maximum range from one another are unlikely to cause crosstalk problems. However, when multiple sensors are mounted in a confined area, take care to avoid crosstalk between them. Alternate the relative position of adjacent sensors and/or reflectors. Sensors positioned above or below one another should not create crosstalk difficulties. Mount the sensor and reflector parallel.

Figure 4. Examples of Appropriate Positions

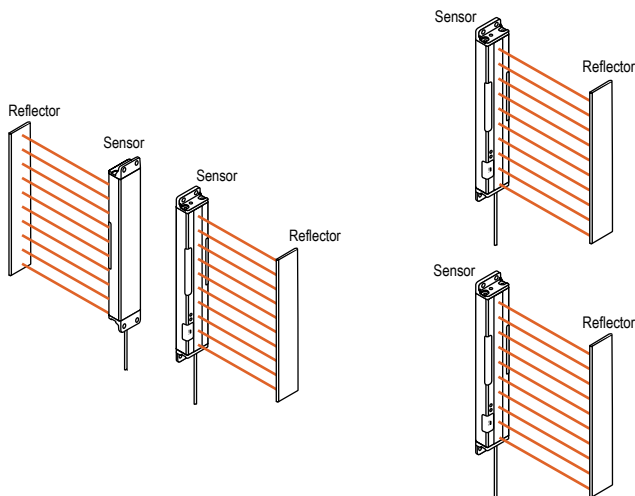
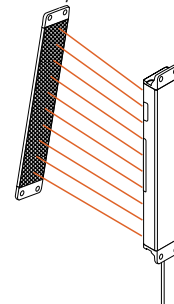

Figure 5. Example of Incorrect Position



Mounting

The wide beam pattern of PVD sensors simplifies their alignment. M4 stainless steel fasteners and two stainless steel brackets are included with each sensor.

Mount the sensor and its reflector, if used, parallel to one another in the same plane, and their tops and bottoms aligned.

1. From a common point of reference, make measurements to locate the sensor and its reflector, if used, in the same plane with their midpoints directly opposite each other.
2. Mount the included brackets to the top and bottom of each sensor, as shown.
3. Mount the sensor in its brackets and the reflector, if used, being careful to position the sensor's red lenses directly facing the reflector.
4. Measure from one or more reference planes (for example, the building or bin floor) to the same point(s) on the emitter and receiver to verify their mechanical alignment. (If the sensors/reflectors are mounted exactly vertical or horizontal, a carpenter's level may be helpful. A straightedge or a string extended between the sensor and the bin wall may also be helpful.)
5. Also check by eye for line-of-sight alignment.
6. Make any necessary final mechanical adjustments, and hand-tighten the bracket hardware.
7. After the electrical wiring is complete, check for beam alignment. If necessary, re-align the emitter and receiver at that time.

Figure 6. PVD Mounting Hardware

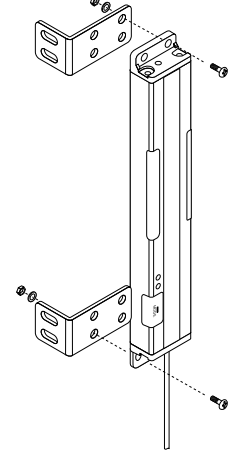

Specifications

Supply Voltage and Current

Input Voltage: 12 V DC to 30 V DC (10% maximum ripple at 10% duty cycle)
Input Current: less than 88 mA at 12 V DC, less than 75 mA at 24 V DC and less than 72 mA at 30 V DC (exclusive of load)

Supply Protection Circuitry

Protected against reverse polarity and transient overvoltages

Sensing Beam

Visible red, 630 nm

Sensing Range

Retroreflective applications: 2 m (6.5 ft) using 25 mm (1 in) wide retroreflective tape
Diffuse applications: 400 mm (15.7 in) with 18% reflectivity gray card target

Sensing Height

4-channel models: 111 mm (4.4 in)
8-channel models: 240 mm (9.4 in)

Beam Spacing

28.6 mm (1.125 in)

Output Configuration

User-selectable via DIP switch:
 1 open-collector PNP (current sourcing) or 1 open-collector NPN (current sinking)

Output Rating

150 mA maximum
 OFF-state leakage current: less than 10 microamps
 ON-state saturation voltage: NPN — less than 1 V DC at 150 mA; PNP — less than 2 V dc at 150 mA

Required Overcurrent Protection



WARNING: Electrical connections must be made by qualified personnel in accordance with local and national electrical codes and regulations.

Overcurrent protection is required to be provided by end product application per the supplied table. Overcurrent protection may be provided with external fusing or via Current Limiting, Class 2 Power Supply. Supply wiring leads < 24 AWG shall not be spliced. For additional product support, go to www.bannerengineering.com.

Supply Wiring (AWG)	Required Overcurrent Protection (Amps)
20	5.0
22	3.0
24	2.0
26	1.0
28	0.8
30	0.5

Output Protection

Protected against false pulse on power-up and short circuit of outputs

Output Response Time

400 ms (includes standard 100 ms ON-delay and 100 ms OFF-delay)

Delay at Power-Up

Less than 1.0 second

Sensing Resolution

See [Dimensions](#) on p. 5 for Minimum Object Detection Zone
Retroreflective: 51 mm at 406 mm range, 100 mm at 2 m (2.0 in dia. at 16 in range, 3.9 in at 6.5 ft); see [Figure 2](#) on p. 2
Diffuse: 55 mm dia. at 400 mm range (2.16 in at 15.7 in range)

Indicators

Green LED: Power ON/OFF
Yellow LED: Output ON/OFF
Job Light (Diffused Green LED): Turned ON and OFF by applying an external signal to the Job input (white wire). The job lights will be active high or active low, depending on DIP switch 4 selection.
Error Light (Diffused Red LED): Turned ON and OFF by detection of an output event when job light is not ON.

Indicator Light Lumens

Light Function	Color	Typical Wavelength	Typical Intensity (lm)
Job Light	Green	525 nm	12
Error Light	Red	625 nm	2.5

Adjustments

4 DIP switches, located behind access panel (default setting is ON position)

Construction

Black painted aluminum housing; acrylic lenses; thermoplastic polyester end caps; thermoplastic elastomer programming switch cover; stainless steel mounting brackets and hardware

Connections

5-conductor PVC-jacketed 2 m (6.5 ft) cable which is either unterminated or terminated with a 5-pin Euro-style quick-disconnect connector, depending on model. Cable diameter is 3.3 mm (0.13 in).

Environmental Rating

NEMA 2; IEC IP62

Operating Conditions

Temperature: 0 °C to +50 °C (+32 °F to +122 °F)
Humidity: 90% at +50 °C maximum relative humidity (non-condensing)

Certifications



Dimensions

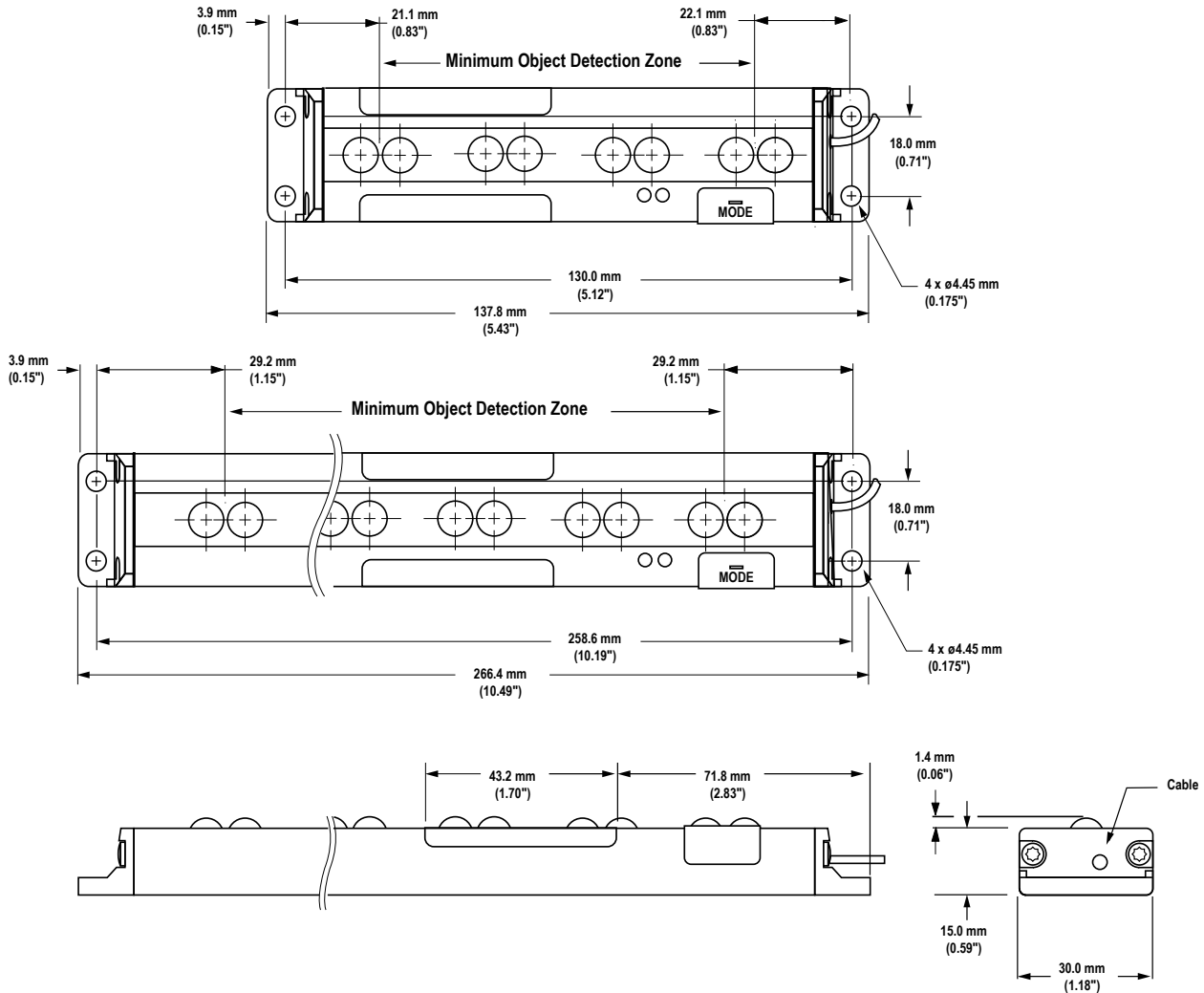

SMBPVA1 Standard Bracket (2 Included with PVD)

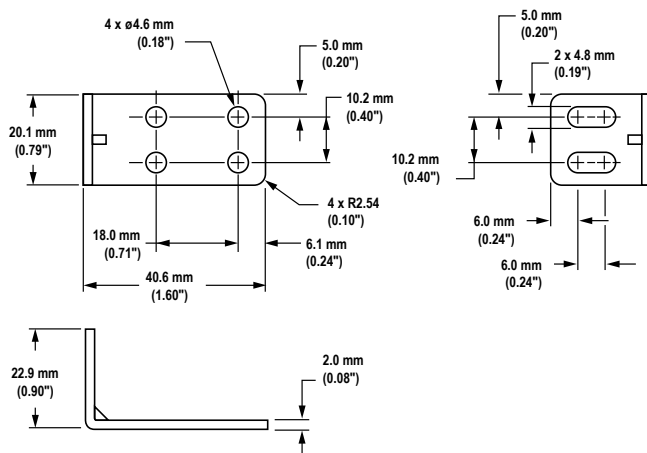

Hardware Included with Each Sensor (kit part number 50532)

Qty	Description
4	Stainless steel Phillips panhead machine screws (M4 x 0.7 x 12)
2	Stainless steel Phillips panhead machine screws (M4 x 0.7 x 6)
2	Stainless steel Phillips panhead machine screws (M4 x 0.7 x 18)
4	Stainless steel hex nuts (M4 x 0.7)
4	Stainless steel lock washers (M4 x 0.7)
1	Plastic screwdriver (3.6 cm/1.4 in long)

Accessories

Cordsets

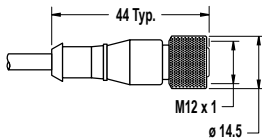
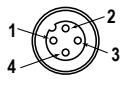
4-Pin Threaded M12/Euro-Style Cordsets—Single Ended				
Model	Length	Style	Dimensions	Pinout (Female)
MQDC-406	1.83 m (6 ft)	Straight		 <p>1 = Brown 2 = White 3 = Blue 4 = Black</p>
MQDC-415	4.57 m (15 ft)			
MQDC-430	9.14 m (30 ft)			
MQDC-450	15.2 m (50 ft)			

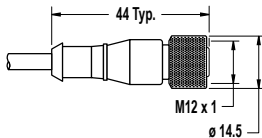
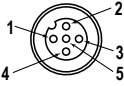
5-Pin Threaded M12/Euro-Style Cordsets—Single Ended				
Model	Length	Style	Dimensions	Pinout (Female)
MQDC1-501.5	0.5 m (1.5 ft)	Straight		 <p>1 = Brown 2 = White 3 = Blue 4 = Black 5 = Gray</p>
MQDC1-506	2 m (6.5 ft)			
MQDC1-515	5 m (16.4 ft)			
MQDC1-530	9 m (29.5 ft)			

Brackets

All measurements are listed in millimeters, unless noted otherwise.

Bracket Selection Table

Bracket Model	Requires Use of Bracket Model(s)	May Be Used with Bracket Model(s)	Bracket Model	Requires Use of Bracket Model(s)	May Be Used with Bracket Model(s)
SMBPVD1 (included with PVD System)	N.A.	SMBPVD100A(B) SMBPVD225A(B) SMBPVA2	SMBPVA9	N.A.	SMBPVD100A(B) SMBPVD225A(B)
SMBPVD100A(B) SMBPVD225A(B)	N.A.	SMBPVD1 SMBPVA5(10) SMBPVA9 SMBPVA2	SMBPVA2	N.A.	SMBPVD100A(B) SMBPVD225A(B)
SMBPVA5C SMBPVA10C	N.A.	SMBPVD100A(B) SMBPVD225A(B) SMBPVA7 SMBPVA8	SMBPVA7	SMBPVA5C or SMBPVA10C	SMBPVD100A(B) SMBPVD225A(B)
			SMBPVA8	SMBPVA5C or SMBPVA10C	SMBPVD100A(B) SMBPVD225A(B)



Note: Standard mounting brackets are included with each PVD System. The following brackets are in addition to the standard brackets.

SMBPVA2

- Set of 4 molded brackets
- Snaps onto standard 28 mm (1.1 in) diameter pipe
- 2 required per sensor



SMBPVA7

- One-piece bracket for mounting to 28 mm (1.1 in) diameter pipe
- Black-painted steel
- Requires SMBPVA..C for mounting at an angle $\pm 90^\circ$

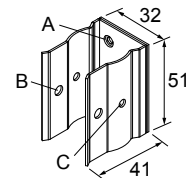

A = M4 x 0.5, B = ϕ 5.2, C = ϕ 4.2

SMBPVA8

- Heavy-duty 2-part bracket mounts to 28 mm (1.1 in) diameter pipe
- Cold-rolled steel with zinc finish
- Requires SMBPVA..C for mounting

A=ø 30.5, B=ø 7.1

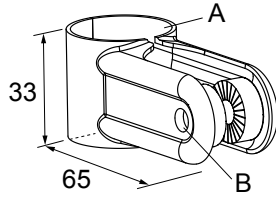

SMBPVA9

- Pair of two-piece swivel brackets
- Mount directly to sensor or to PVD or PVA protective brackets
- Designed for mounting sensor to look down



SMBPVD..A & SMBPVD..AB

- Heavy-duty protection brackets
- Some models include DIP-switch access port
- Cold-rolled steel with zinc finish
- May be used with SMBPVA..C for mounting to SMBPVA7 or SMBPVA8 brackets

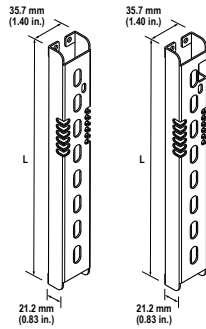

Models with DIP Switch Access Port	Models with No DIP Switch Access	L
SMBPVD100A	SMBPVD100AB	140 mm (5.5 in)
SMBPVD225A	SMBPVD225AB	269 mm (10.6 in)

SMBPV..C

- Back-mounted bracket for mounting to SMBPVA7 or SMBPVA8 brackets
- Cold-rolled steel with zinc finish

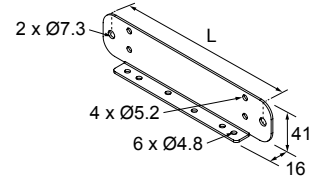

Model	L
SMBPVA5C	170.0 mm
SMBPVA10C	298.5 mm

Retroreflective Tape

Model	Reflectivity Factor	Maximum Temperature	Size
BRT-THG-1-100	0.7	+60 °C (+140 °F)	25 mm (1 in) wide, 2.5 m (100 in) long
BRT-THG-2-100	0.7	+60 °C (+140 °F)	50 mm (2 in) wide, 2.5 m (100 in) long
BRT-THG-3-100	0.7	+60 °C (+140 °F)	75 mm (3 in) wide, 2.5 m (100 in) long

Banner Engineering Corp. Limited Warranty

Banner Engineering Corp. warrants its products to be free from defects in material and workmanship for one year following the date of shipment. Banner Engineering Corp. will repair or replace, free of charge, any product of its manufacture which, at the time it is returned to the factory, is found to have been defective during the warranty period. This warranty does not cover damage or liability for misuse, abuse, or the improper application or installation of the Banner product.

THIS LIMITED WARRANTY IS EXCLUSIVE AND IN LIEU OF ALL OTHER WARRANTIES WHETHER EXPRESS OR IMPLIED (INCLUDING, WITHOUT LIMITATION, ANY WARRANTY OF MERCHANTABILITY OR FITNESS FOR A PARTICULAR PURPOSE), AND WHETHER ARISING UNDER COURSE OF PERFORMANCE, COURSE OF DEALING OR TRADE USAGE.

This Warranty is exclusive and limited to repair or, at the discretion of Banner Engineering Corp., replacement. IN NO EVENT SHALL BANNER ENGINEERING CORP. BE LIABLE TO BUYER OR ANY OTHER PERSON OR ENTITY FOR ANY EXTRA COSTS, EXPENSES, LOSSES, LOSS OF PROFITS, OR ANY INCIDENTAL, CONSEQUENTIAL OR SPECIAL DAMAGES RESULTING FROM ANY PRODUCT DEFECT OR FROM THE USE OR INABILITY TO USE THE PRODUCT, WHETHER ARISING IN CONTRACT OR WARRANTY, STATUTE, TORT, STRICT LIABILITY, NEGLIGENCE, OR OTHERWISE.

Banner Engineering Corp. reserves the right to change, modify or improve the design of the product without assuming any obligations or liabilities relating to any product previously manufactured by Banner Engineering Corp. Any misuse, abuse, or improper application or installation of this product or use of the product for personal protection applications when the product is identified as not intended for such purposes will void the product warranty. Any modifications to this product without prior express approval by Banner Engineering Corp will void the product warranties. All specifications published in this document are subject to change; Banner reserves the right to modify product specifications or update documentation at any time. Specifications and product information in English supersede that which is provided in any other language. For the most recent version of any documentation, refer to: www.bannerengineering.com.

For patent information, see www.bannerengineering.com/patents.