

MC14541B

Programmable Timer

The MC14541B programmable timer consists of a 16–stage binary counter, an integrated oscillator for use with an external capacitor and two resistors, an automatic power–on reset circuit, and output control logic.

Timing is initialized by turning on power, whereupon the power–on reset is enabled and initializes the counter, within the specified V_{DD} range. With the power already on, an external reset pulse can be applied. Upon release of the initial reset command, the oscillator will oscillate with a frequency determined by the external RC network. The 16–stage counter divides the oscillator frequency (f_{OSC}) with the n^{th} stage frequency being $f_{OSC}/2^n$.

- Available Outputs 2⁸, 2¹⁰, 2¹³ or 2¹⁶
- Increments on Positive Edge Clock Transitions
- Built–in Low Power RC Oscillator ($\pm 2\%$ accuracy over temperature range and $\pm 20\%$ supply and $\pm 3\%$ over processing at < 10 kHz)
- Oscillator May Be Bypassed if External Clock Is Available (Apply external clock to Pin 3)
- External Master Reset Totally Independent of Automatic Reset Operation
- Operates as 2ⁿ Frequency Divider or Single Transition Timer
- Q/\bar{Q} Select Provides Output Logic Level Flexibility
- Reset (auto or master) Disables Oscillator During Resetting to Provide No Active Power Dissipation
- Clock Conditioning Circuit Permits Operation with Very Slow Clock Rise and Fall Times
- Automatic Reset Initializes All Counters On Power Up
- Supply Voltage Range = 3.0 Vdc to 18 Vdc with Auto Reset Disabled (Pin 5 = V_{DD})
= 8.5 Vdc to 18 Vdc with Auto Reset Enabled (Pin 5 = V_{SS})

MAXIMUM RATINGS (Voltages Referenced to V_{SS}) (Note 2.)

Symbol	Parameter	Value	Unit
V_{DD}	DC Supply Voltage Range	–0.5 to +18.0	V
V_{in}, V_{out}	Input or Output Voltage Range (DC or Transient)	–0.5 to $V_{DD} + 0.5$	V
I_{in}	Input Current (DC or Transient)	± 10 (per Pin)	mA
I_{out}	Output Current (DC or Transient)	± 45 (per Pin)	mA
P_D	Power Dissipation, per Package (Note 3.)	500	mW
T_A	Ambient Temperature Range	–55 to +125	°C
T_{stg}	Storage Temperature Range	–65 to +150	°C
T_L	Lead Temperature (8–Second Soldering)	260	°C

2. Maximum Ratings are those values beyond which damage to the device may occur.
3. Temperature Derating:
Plastic “P and D/DW” Packages: – 7.0 mW/°C From 65°C To 125°C



ON Semiconductor

<http://onsemi.com>

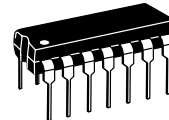

PDIP–14
P SUFFIX
CASE 646

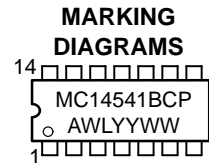

SOIC–14
D SUFFIX
CASE 751A



TSSOP–14
DT SUFFIX
CASE 948G

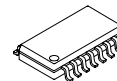
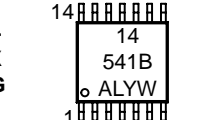

SOEIAJ–14
F SUFFIX
CASE 965

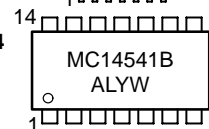

A = Assembly Location
WL, L = Wafer Lot
YY, Y = Year
WW, W = Work Week

ORDERING INFORMATION

Device	Package	Shipping
MC14541BCP	PDIP–14	2000/Box
MC14541BD	SOIC–14	55/Rail
MC14541BDR2	SOIC–14	2500/Tape & Reel
MC14541BDT	TSSOP–14	96/Rail
MC14541BDTR2	TSSOP–14	2500/Tape & Reel
MC14541BF	SOEIAJ–14	See Note 1.
MC14541BFEL	SOEIAJ–14	See Note 1.

1. For ordering information on the EIAJ version of the SOIC packages, please contact your local ON Semiconductor representative.

This device contains protection circuitry to guard against damage due to high static voltages or electric fields. However, precautions must be taken to avoid applications of any voltage higher than maximum rated voltages to this high–impedance circuit. For proper operation, V_{in} and V_{out} should be constrained to the range $V_{SS} \leq (V_{in} \text{ or } V_{out}) \leq V_{DD}$.

Unused inputs must always be tied to an appropriate logic voltage level (e.g., either V_{SS} or V_{DD}). Unused outputs must be left open.

MC14541B

PIN ASSIGNMENT

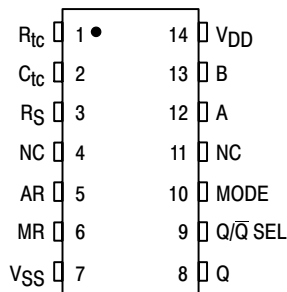

NC = NO CONNECTION

ELECTRICAL CHARACTERISTICS (Voltages Referenced to V_{SS})

Characteristic	Symbol	V _{DD} Vdc	- 55° C		25° C			125° C		Unit
			Min	Max	Min	Typ (4.)	Max	Min	Max	
Output Voltage V _{in} = V _{DD} or 0	"0" Level V _{OL}	5.0	—	0.05	—	0	0.05	—	0.05	Vdc
		10	—	0.05	—	0	0.05	—	0.05	
15		—	0.05	—	0	0.05	—	0.05		
V _{in} = 0 or V _{DD}	"1" Level V _{OH}	5.0	4.95	—	4.95	5.0	—	4.95	—	Vdc
		10	9.95	—	9.95	10	—	9.95	—	
		15	14.95	—	14.95	15	—	14.95	—	
Input Voltage (V _O = 4.5 or 0.5 Vdc) (V _O = 9.0 or 1.0 Vdc) (V _O = 13.5 or 1.5 Vdc)	"0" Level V _{IL}	5.0	—	1.5	—	2.25	1.5	—	1.5	Vdc
		10	—	3.0	—	4.50	3.0	—	3.0	
		15	—	4.0	—	6.75	4.0	—	4.0	
(V _O = 0.5 or 4.5 Vdc) (V _O = 1.0 or 9.0 Vdc) (V _O = 1.5 or 13.5 Vdc)	"1" Level V _{IH}	5.0	3.5	—	3.5	2.75	—	3.5	—	Vdc
		10	7.0	—	7.0	5.50	—	7.0	—	
		15	11	—	11	8.25	—	11	—	
Output Drive Current (V _{OH} = 2.5 Vdc) (V _{OH} = 9.5 Vdc) (V _{OH} = 13.5 Vdc)	Source I _{OH}	5.0	-7.96	—	-6.42	-12.83	—	-4.49	—	mAdc
		10	-4.19	—	-3.38	-6.75	—	-2.37	—	
		15	-16.3	—	-13.2	-26.33	—	-9.24	—	
(V _{OL} = 0.4 Vdc) (V _{OL} = 0.5 Vdc) (V _{OL} = 1.5 Vdc)	Sink I _{OL}	5.0	1.93	—	1.56	3.12	—	1.09	—	mAdc
		10	4.96	—	4.0	8.0	—	2.8	—	
		15	19.3	—	15.6	31.2	—	10.9	—	
Input Current	I _{in}	15	—	± 0.1	—	± 0.00001	± 0.1	—	± 1.0	μAdc
Input Capacitance (V _{in} = 0)	C _{in}	—	—	—	—	5.0	7.5	—	—	pF
Quiescent Current (Pin 5 is High) Auto Reset Disabled	I _{DD}	5.0	—	5.0	—	0.005	5.0	—	150	μAdc
		10	—	10	—	0.010	10	—	300	
		15	—	20	—	0.015	20	—	600	
Auto Reset Quiescent Current (Pin 5 is low)	I _{DDR}	10	—	250	—	30	250	—	1500	μAdc
		15	—	500	—	82	500	—	2000	
Supply Current (5.) (6.) (Dynamic plus Quiescent)	I _D	5.0	I _D = (0.4 μA/kHz) f + I _{DD}						μAdc	
	10	I _D = (0.8 μA/kHz) f + I _{DD}								
	15	I _D = (1.2 μA/kHz) f + I _{DD}								

4. Data labelled "Typ" is not to be used for design purposes but is intended as an indication of the IC's potential performance.

5. The formulas given are for the typical characteristics only at 25°C.

6. When using the on chip oscillator the total supply current (in μAdc) becomes: $I_T = I_D + 2 C_{tc} V_{DD} f \times 10^{-3}$ where I_D is in μA, C_{tc} is in pF, V_{DD} in Volts DC, and f in kHz. (see Fig. 3) Dissipation during power-on with automatic reset enabled is typically 50 μA @ V_{DD} = 10 Vdc.

MC14541B

SWITCHING CHARACTERISTICS (7.) ($C_L = 50 \text{ pF}$, $T_A = 25^\circ\text{C}$)

Characteristic	Symbol	V _{DD}	Min	Typ (8.)	Max	Unit
Output Rise and Fall Time $t_{TLH}, t_{THL} = (1.5 \text{ ns/pF}) C_L + 25 \text{ ns}$ $t_{TLH}, t_{THL} = (0.75 \text{ ns/pF}) C_L + 12.5 \text{ ns}$ $t_{TLH}, t_{THL} = (0.55 \text{ ns/pF}) C_L + 9.5 \text{ ns}$	t_{TLH}, t_{THL}	5.0 10 15	— — —	100 50 40	200 100 80	ns
Propagation Delay, Clock to Q (2 ⁸ Output) $t_{PLH}, t_{PHL} = (1.7 \text{ ns/pF}) C_L + 3415 \text{ ns}$ $t_{PLH}, t_{PHL} = (0.66 \text{ ns/pF}) C_L + 1217 \text{ ns}$ $t_{PLH}, t_{PHL} = (0.5 \text{ ns/pF}) C_L + 875 \text{ ns}$	t_{PLH}, t_{PHL}	5.0 10 15	— — —	3.5 1.25 0.9	10.5 3.8 2.9	μs
Propagation Delay, Clock to Q (2 ¹⁶ Output) $t_{PHL}, t_{PLH} = (1.7 \text{ ns/pF}) C_L + 5915 \text{ ns}$ $t_{PHL}, t_{PLH} = (0.66 \text{ ns/pF}) C_L + 3467 \text{ ns}$ $t_{PHL}, t_{PLH} = (0.5 \text{ ns/pF}) C_L + 2475 \text{ ns}$	t_{PHL}, t_{PLH}	5.0 10 15	— — —	6.0 3.5 2.5	18 10 7.5	μs
Clock Pulse Width	$t_{WH(cl)}$	5.0 10 15	900 300 225	300 100 85	— — —	ns
Clock Pulse Frequency (50% Duty Cycle)	f_{cl}	5.0 10 15	— — —	1.5 4.0 6.0	0.75 2.0 3.0	MHz
MR Pulse Width	$t_{WH(R)}$	5.0 10 15	900 300 225	300 100 85	— — —	ns
Master Reset Removal Time	t_{rem}	5.0 10 15	420 200 200	210 100 100	— — —	ns

7. The formulas given are for the typical characteristics only at 25°C.

8. Data labelled "Typ" is not to be used for design purposes but is intended as an indication of the IC's potential performance.

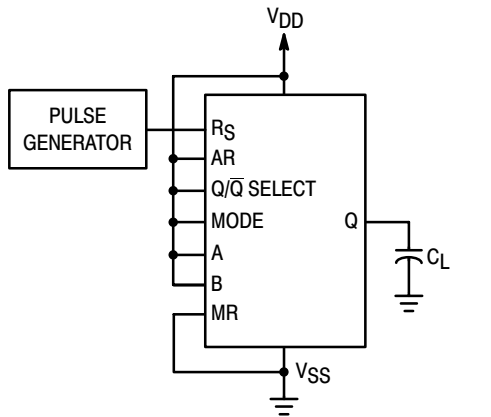

(R_{tc} AND C_{tc} OUTPUTS ARE LEFT OPEN)

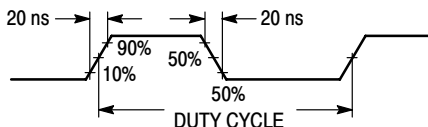

Figure 1. Power Dissipation Test Circuit and Waveform

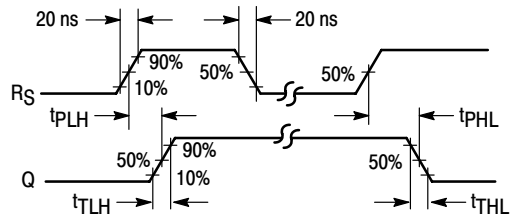
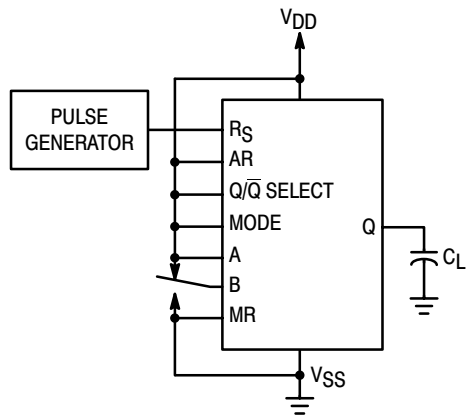
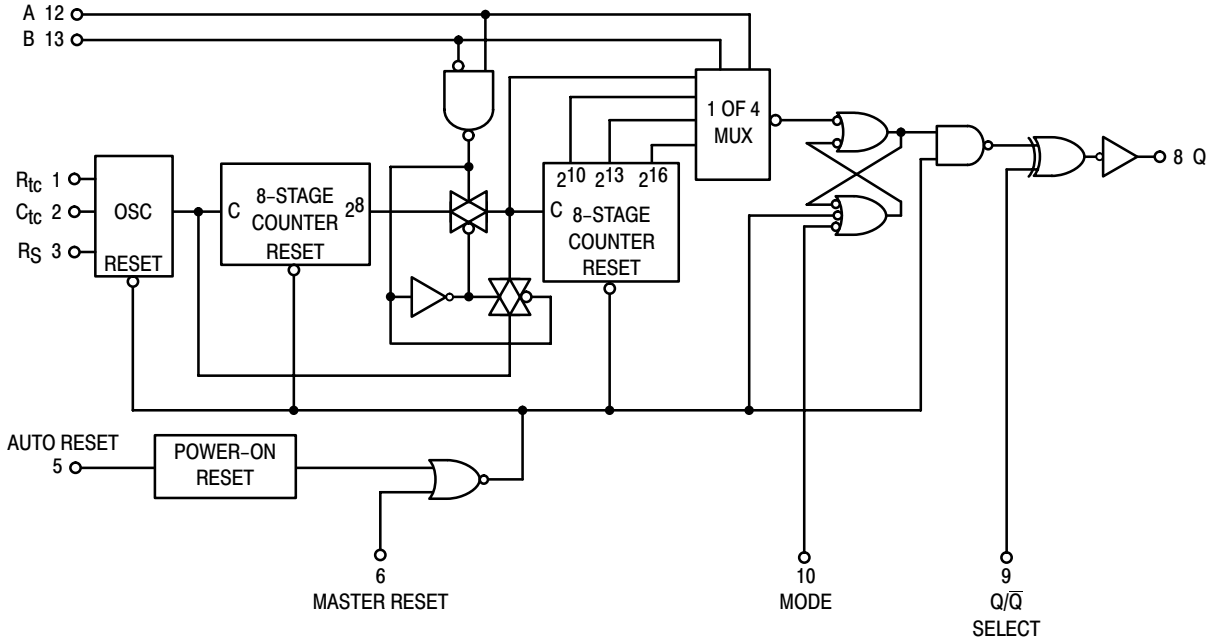

Figure 2. Switching Time Test Circuit and Waveforms

MC14541B

EXPANDED BLOCK DIAGRAM



V_{DD} = PIN 14
V_{SS} = PIN 7

FREQUENCY SELECTION TABLE

A	B	Number of Counter Stages n	Count 2 ⁿ
0	0	13	8192
0	1	10	1024
1	0	8	256
1	1	16	65536

TRUTH TABLE

Pin	State	
	0	1
Auto Reset, 5	Auto Reset Operating	Auto Reset Disabled
Master Reset, 6	Timer Operational	Master Reset On
Q/ \bar{Q} , 9	Output Initially Low After Reset	Output Initially High After Reset
Mode, 10	Single Cycle Mode	Recycle Mode

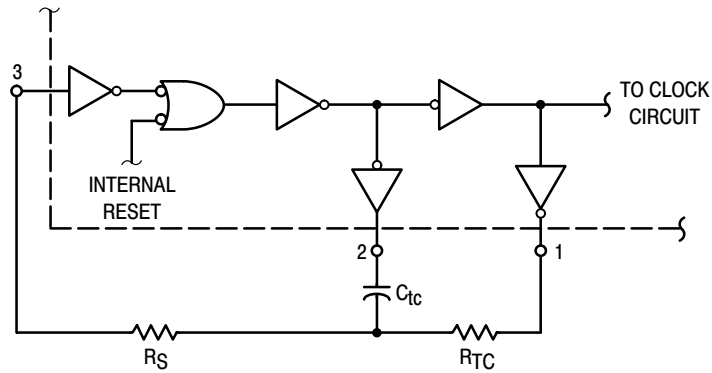

Figure 3. Oscillator Circuit Using RC Configuration

TYPICAL RC OSCILLATOR CHARACTERISTICS

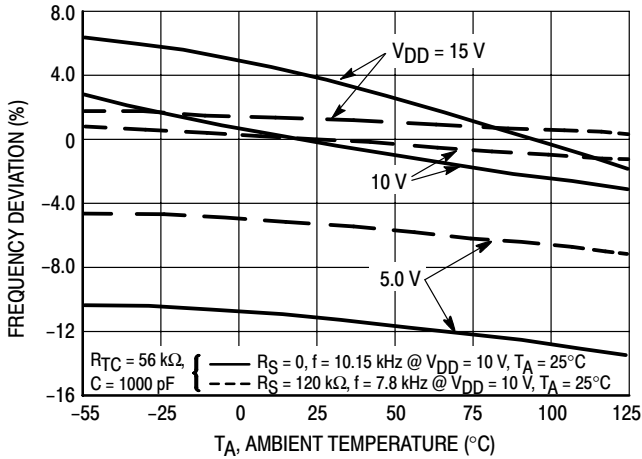

Figure 4. RC Oscillator Stability

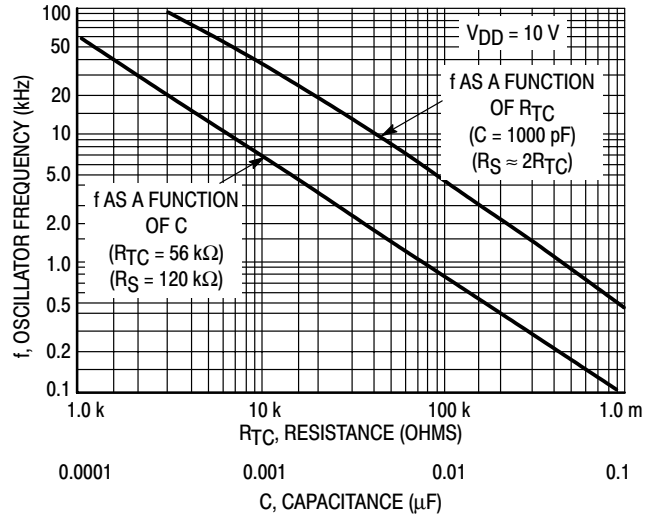

Figure 5. RC Oscillator Frequency as a Function of R_{TC} and C_{TC}

OPERATING CHARACTERISTICS

With Auto Reset pin set to a “0” the counter circuit is initialized by turning on power. Or with power already on, the counter circuit is reset when the Master Reset pin is set to a “1”. Both types of reset will result in synchronously resetting all counter stages independent of counter state. Auto Reset pin when set to a “1” provides a low power operation.

The RC oscillator as shown in Figure 3 will oscillate with a frequency determined by the external RC network i.e.,

$$f = \frac{1}{2.3 R_{TC} C_{TC}} \quad \text{if } (1 \text{ kHz} \leq f \leq 100 \text{ kHz})$$

and $R_S \approx 2 R_{TC}$ where $R_S \geq 10 \text{ k}\Omega$

The time select inputs (A and B) provide a two-bit address to output any one of four counter stages ($2^8, 2^{10}, 2^{13}$ and 2^{16}). The 2^n counts as shown in the Frequency Selection Table represents the Q output of the N^{th} stage of the counter. When A is “1”, 2^{16} is selected for both states of B. However,

when B is “0”, normal counting is interrupted and the 9th counter stage receives its clock directly from the oscillator (i.e., effectively outputting 2^8).

The Q/\bar{Q} select output control pin provides for a choice of output level. When the counter is in a reset condition and Q/\bar{Q} select pin is set to a “0” the Q output is a “0”, correspondingly when Q/\bar{Q} select pin is set to a “1” the Q output is a “1”.

When the mode control pin is set to a “1”, the selected count is continually transmitted to the output. But, with mode pin “0” and after a reset condition the R_S flip-flop (see Expanded Block Diagram) resets, counting commences, and after $2^n - 1$ counts the R_S flip-flop sets which causes the output to change state. Hence, after another $2^n - 1$ counts the output will not change. Thus, a Master Reset pulse must be applied or a change in the mode pin level is required to reset the single cycle operation.

DIGITAL TIMER APPLICATION

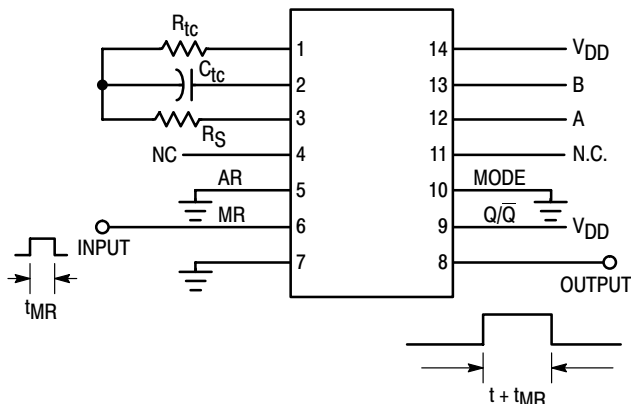

When Master Reset (MR) receives a positive pulse, the internal counters and latch are reset. The Q output goes high and remains high until the selected (via A and B) number of clock pulses are counted, the Q output then goes low and remains low until another input pulse is received.

This “one shot” is fully retriggerable and as accurate as the input frequency. An external clock can be used (pin 3 is the clock input, pins 1 and 2 are outputs) if additional accuracy is needed.

Notice that a setup time equal to the desired pulse width output is required immediately following initial power up, during which time Q output will be high.