

# VAL-US-48/40-P - Type 2 surge protection plug



2910333

<https://www.phoenixcontact.com/us/products/2910333>

Please be informed that the data shown in this PDF document is generated from our online catalog. Please find the complete data in the user documentation. Our general terms of use for downloads are valid.



UL Recognized type 2 SPD and IEC type 2 surge protection plug with a varistor and thermal disconnect for use with VAL-US base elements, mechanical and visual fault warning

## Product description

Surge protective device replacement plug

## Commercial data

Item number	2910333
Packing unit	1 pc
Sales key	CL18
Product key	CL1321
Catalog page	Page 90 (C-4-2019)
GTIN	4055626444468
Weight per piece (including packing)	35.1 g
Weight per piece (excluding packing)	29 g
Customs tariff number	85363030
Country of origin	DE

# VAL-US-48/40-P - Type 2 surge protection plug

2910333

<https://www.phoenixcontact.com/us/products/2910333>

## Technical data

### Notes

General	Used in:
---------	----------

### Product properties

IEC test classification	II
	T2
EN type	T2
IEC power supply system	DC
Type	Male
Product type	Replacement plug
Product family	VALVETRAB MS
Number of positions	1
Surge protection fault message	optical

### Insulation characteristics

Overvoltage category	III
Pollution degree	2

### Electrical properties

Nominal frequency $f_N$	50 Hz (60 Hz)
-------------------------	---------------

### Connection data

Connection method	VALVETRAB plug-in system
-------------------	--------------------------

### Dimensions

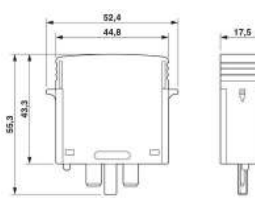
Dimensional drawing	
Width	17.5 mm
Height	52.4 mm
Depth	55.3 mm
Horizontal pitch	1 Div.

### Material specifications

Flammability rating according to UL 94	V-0
CTI value of material	600
Insulating material	PA 6.6/PBT
Material group	I
Housing material	PA 6.6

# VAL-US-48/40-P - Type 2 surge protection plug



2910333

<https://www.phoenixcontact.com/us/products/2910333>

	PBT
--	-----

## Protective circuit

Mode of protection	L-N
	L-PEN
	N-PE
Direction of action	1L-N/PE
Nominal voltage $U_N$	60 V DC $\pm 10\%$
	-48 V DC $\pm 10\%$ (RRH)
Nominal frequency $f_N$	50 Hz (60 Hz)
Maximum continuous voltage $U_C$	100 V DC
Residual current $I_{PE}$	$\leq 450 \mu A$
Standby power consumption $P_C$	$\leq 35 \text{ mVA}$
Nominal discharge current $I_n$ (8/20) $\mu s$	15 kA
Maximum discharge current $I_{max}$ (8/20) $\mu s$	40 kA
Short-circuit current rating $I_{SCCR}$	25 kA
Voltage protection level $U_p$	$\leq 0.55 \text{ kV}$
Residual voltage $U_{res}$	$\leq 0.55 \text{ kV}$ (at $I_n$ )
	$\leq 0.425 \text{ kV}$ (at 10 kA)
	$\leq 0.325 \text{ kV}$ (at 5 kA)
	$\leq 0.275 \text{ kV}$ (at 3 kA)
TOV behavior at $U_T$	100 V AC (5 s / withstand mode)
Max. backup fuse with branch wiring	100 A (gG)

## Additional technical data

Maximum discharge current $I_{max}$ (8/20) $\mu s$	40 kA
--	-------

## Environmental and real-life conditions

### Ambient conditions

Degree of protection	IP20
Ambient temperature (operation)	-40 °C ... 80 °C
Ambient temperature (storage/transport)	-40 °C ... 80 °C
Altitude	$\leq 2000 \text{ m}$ (amsl)
Permissible humidity (operation)	5 % ... 95 %
Shock (operation)	25g (Half-sine / 11 ms / 3x $\pm X$ , $\pm Y$ , $\pm Z$ )
Vibration (operation)	5g (10 ... 500 Hz / 2.5 h / X, Y, Z)

## Approvals

### UL specifications

Maximum continuous operating voltage MCOV	100 V DC
UL type	type 4
Nominal discharge current $I_n$	20 kA
Maximum Surge Current per Phase	40 kA
	L-N

# VAL-US-48/40-P - Type 2 surge protection plug



2910333

<https://www.phoenixcontact.com/us/products/2910333>

Mode of protection	L-G
	N-G
Nominal voltage	60 V DC
Power distribution system	Single phase
Measured limiting voltage MLV	720 V
SPD Type	4CA

## Standards and regulations

### Air clearances and creepage distances

Standards/regulations	EN 60664-1 / EN 61643-11
Standards/specifications	IEC 61643-11
Note	2011
Standards/specifications	EN 61643-11
Note	2012

## Mounting

Mounting type	on base element
---------------	-----------------

# VAL-US-48/40-P - Type 2 surge protection plug

2910333

<https://www.phoenixcontact.com/us/products/2910333>



## Drawings

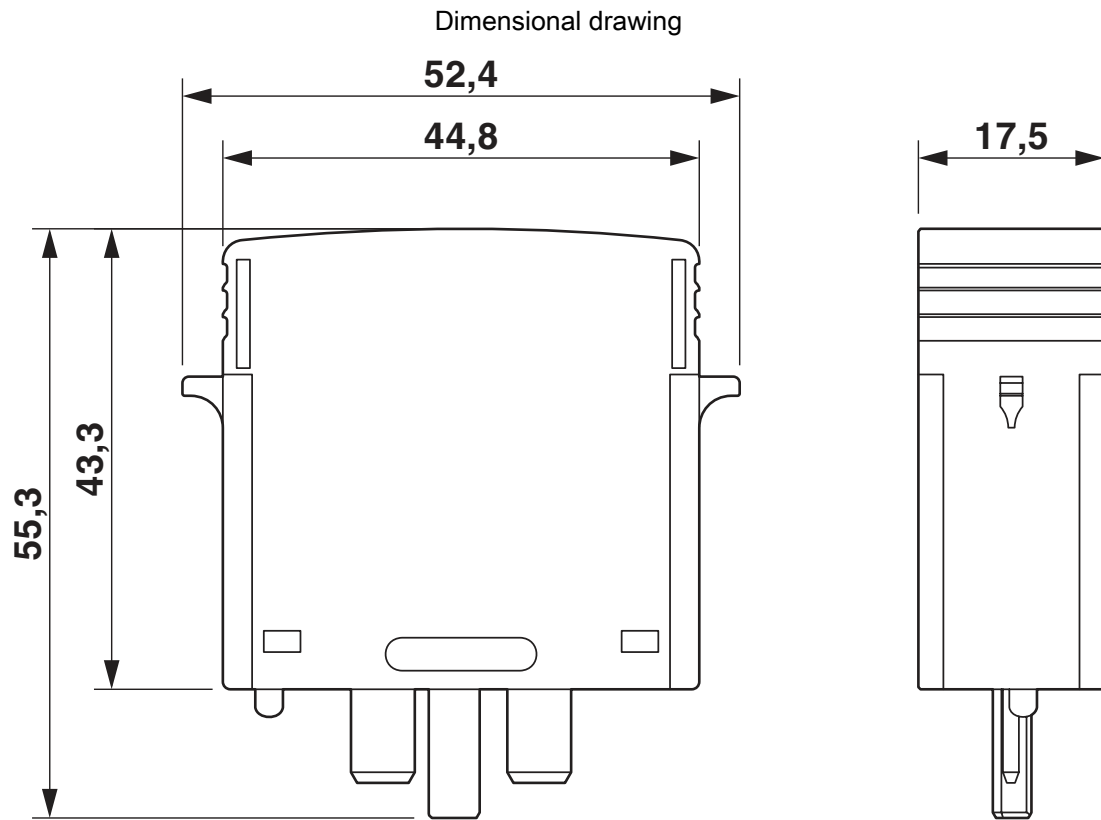

Circuit diagram



# VAL-US-48/40-P - Type 2 surge protection plug



2910333

<https://www.phoenixcontact.com/us/products/2910333>

## Approvals

To download certificates, visit the product detail page: <https://www.phoenixcontact.com/us/products/2910333>



**cUL Recognized**

Approval ID: FILE E 330181



**UL Recognized**

Approval ID: FILE E 330181

**cULus Recognized**

# VAL-US-48/40-P - Type 2 surge protection plug



2910333

<https://www.phoenixcontact.com/us/products/2910333>

## Classifications

### ECLASS

ECLASS-11.0	27130890
ECLASS-13.0	27171292

### ETIM

ETIM 8.0	EC002496
----------	----------

### UNSPSC

UNSPSC 21.0	39121600
-------------	----------

# VAL-US-48/40-P - Type 2 surge protection plug



2910333

<https://www.phoenixcontact.com/us/products/2910333>

## Environmental product compliance

China RoHS	Environmentally friendly use period: unlimited = EFUP-e
	No hazardous substances above threshold values



# VAL-US-48/40-P - Type 2 surge protection plug



2910333

<https://www.phoenixcontact.com/us/products/2910333>

## Accessories

### VAL-US-48/40/1+0-FM - Type 2 surge protection device

2910343

<https://www.phoenixcontact.com/us/products/2910343>



Surge protective device, single channel with remote indicator contact for 48 V DC.

---

### VAL-US-48/40/1+1V-FM - Type 2 surge protection device

2910344

<https://www.phoenixcontact.com/us/products/2910344>



Surge protective device, two channels with remote indicator contact for 48 V DC, 2-wire plus ground

Phoenix Contact 2023 © - all rights reserved

<https://www.phoenixcontact.com>

Phoenix Contact USA  
586 Fulling Mill Road  
Middletown, PA 17057, United States  
(+717) 944-1300  
[info@phoenixcon.com](mailto:info@phoenixcon.com)