



# BW16-Kit specification

Version V1.2.2

Copyright ©2022

## Document resume

Version	Date	Revise content	Edition	Approve
V1.0.0	2021.08.10	First Edition	Xiaocheng Li	Hong Xu
V1.1.1	2022.05.13	Circuit upgrade, Data Update	Yingying Chen	Hong Xu
V1.2.2	2022.06.14	1、 Change USB interface from Micro USB to Type C USB 2、 UART port connected by USB interface, changed from AT UART to Log UART 3、 Add power indicator 4、 Reduce the number of pins and remove the pins of NC 5、 Add to the record of the Auto Upload Mode circuit design	Yingying Chen	Hong Xu

## Content

1. Product Overview.....	4
1.1. Characteristic.....	4
2. Main parameters.....	5
2.1. Power supply selection.....	6
2.2. Static electricity requirements.....	6
2.3. Electrical characteristics.....	6
2.4. BW16-Kit RF performance.....	7
3. Appearance size.....	9
4. Indicator light and button description.....	10
5. Pin definition.....	11
6. Schematic diagram.....	13
7. Product Related models.....	14
8. Product considerations.....	14
9. Product packaging information.....	14
10. Contact us.....	15
Disclaimer and copyright announcement.....	16
Note.....	16

## 1. Product Overview

BW16-Kit is a development board designed for the BW16 module. BW16 is a dual-frequency Wi-Fi + Bluetooth SoC module developed by B&T based on RTL8720DN chip. BW16 supports dual-frequency (2.4GHz or 5GHz) WLAN and low-power Bluetooth 5.0, integrates ARM V8 (compatible with Cortex-M4F) high-performance MCU, ARM V8M (compatible with Cortex-M0) low-power MCU, WLAN (802.11 a/B/g / n), MAC, Bluetooth baseband and RF baseband, and provides a set of configurable GPIO ports for the control of different peripheral devices.

It has the following features:

**Figure 1 RTL8720DN chip architecture**

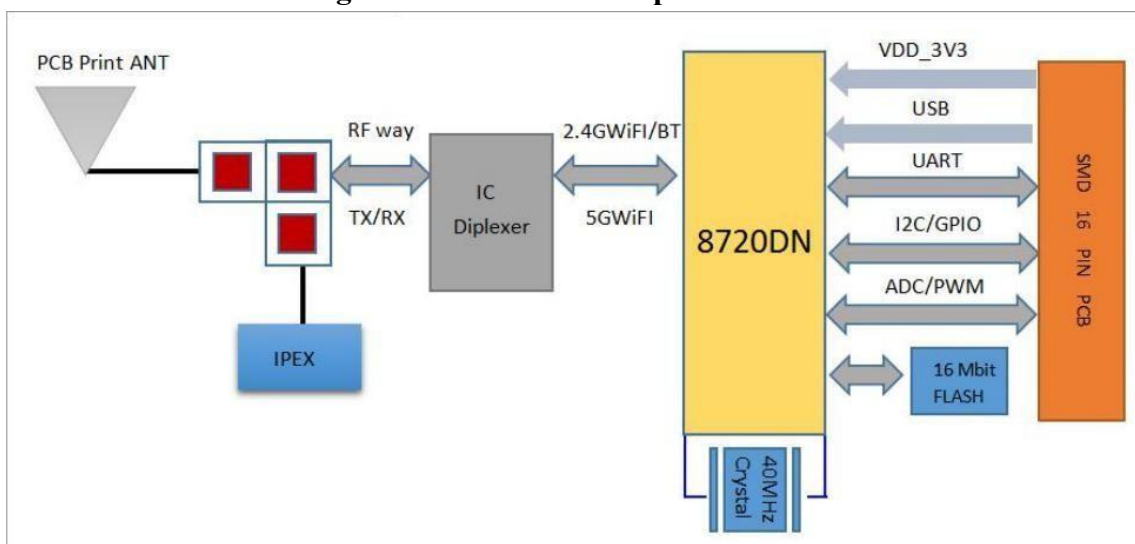

### 1.1. Characteristic

- Supports 802.11a/B/g/n,2.4GHz or 5GHz.
- Support HT20 and HT40 mode.
- Supports low-power Beacon listening mode, low-power receiver mode, and low-power suspension mode.
- Built-in AES / DES / SHA hardware engine.
- Supports TrustZone-M and secure startup.
- Support SWD to debug port access protection and disable mode.
- BLE 5.0 is supported.
- Bluetooth supports high power mode (7dBm, sharing the same PA with Wi-Fi).
- Wi-Fi and Bluetooth share the same antenna.

- Supports the STA/AP/STA + AP operation mode.
- Simple Config (apps) that support Android and IOS Wi-Fi one-click Network allocation.
- Supports Bluetooth-assisted network distribution.
- Supports local serial port upgrades and remote firmware upgrades (FOTA).
- Supports secondary development and programming in Linux and Window environments.
- Supports Arduino development.

## 2. Main parameters

**Table 1 main parameters**

<b>Model</b>	BW16-Kit
<b>Suitable modules</b>	BW16
<b>Package</b>	DIP-22(2.54 spacing standard row pin)
<b>Size</b>	50.4*25.4(±0.2)mm
<b>Antenna</b>	Board-mounted PCB antenna
<b>Spectrum Range</b>	2400-2483.5MHz or 5180-5825MHz
<b>WiFi</b>	Supports 802.11 a/B/g/n
<b>Bluetooth</b>	BLE 5.0
<b>Operation temperature</b>	-40°C ~ 85°C
<b>Storage environment</b>	-40 °C ~ 125 °C , < 90%RH
<b>Power supply</b>	Supply voltage 5V current greater than 500mA
<b>Interfaces</b>	UART/GPIO/ADC/PWM/IIC/SPI/SWD
<b>I/O ports</b>	13 GPIO (including TX0\RX0 and TX1\RX1)
<b>Security</b>	AES / DES / SHA
<b>Flash</b>	Default value: 2MB. Valid values: 4MB.

## 2.1. Power supply selection

You can choose one of the following three power supply methods to supply power to BW16-Kit:

- Type-C interface power supply (default)
- 5V and GND pin power supply
- 3V3 and GND pin power supply

We recommend that you select the first power supply mode: Type-C interface power supply.

## 2.2. Static electricity requirements

BW16-Kit Development Board is electrostatic sensitive equipment, special preventive measures should be taken when carrying.



Figure 2 ESD anti-static diagram

## 2.3. Electrical characteristics

Table 2 Electrical Characteristics Table

Parameter	Conditio	Minimum	Typical	Maximum	Com
Supply voltage	VDD	4.5	5	5.3	V
Digital I/O voltage	-	1.76	1.8-3.3	3.3	V

## 2.4. BW16-Kit RF performance

**Table 3 2.4g Wi-Fi RF performance table**

Depaint	Typical value			Compa
Spectrum Range	2400-2483.5			MHz
Output power				
Rate mode	Minimum	Typical	Maximum	Compa
In 11b mode, PA output power	-	16	-	dBm
In 11G mode, PA output power	-	15	-	dBm
11n mode HT20,PA output power	-	14	-	dBm
11n mode HT40,PA output power	-	14	-	dBm
Receiving sensitivitiy				
Rate mode	Minimum	Typical	Maximum	Compa
11b,1 Mbps	-	-98	-	dBm
11b,11 Mbps	-	-90	-	dBm
11g, 6 Mbps	-	-93	-	dBm
11g,54 Mbps	-	-76	-	dBm
11n,HT20 (MCS7)	-	-73	-	dBm
11n,HT40 (MCS7)	-	-71	-	dBm

**Table 4 RF performance of 5G Wi-Fi**

Depaint	Typical value			Compa
Spectrum Range	5180-5825MHz			MHz
<b>Output power</b>				
Rate mode	Minimum	Typical	Maximum	Compa
In 11a mode, PA output power	-	14	-	dBm
11n mode HT20,PA output power	-	13	-	dBm
11n mode HT40,PA output power	-	13	-	dBm
<b>Receiving sensitivity</b>				
Rate mode	Minimum	Typical	Maximum	Compa
11a,6 Mbps	-	-93	-	dBm
11a,54 Mbps	-	-76	-	dBm
11n,HT40 (MCS7)	-	-73	-	dBm
11n,HT20 (MCS7)	-	-71	-	dBm

**Table 5 BLE RF performance table**

Depaint	Typical value			Compa
Spectrum Range	2400-2483.5			MHz
<b>Output power</b>				
Rate mode	Minimum	Typical	Maximum	Compa
1Mbps	-	6	-	dBm
<b>Receiving sensitivity</b>				
Rate mode	Minimum	Typical	Maximum	Compa
1Mbps sensitivity @ 30.8% PER	-	-96	-	dBm



### 3. Appearance size

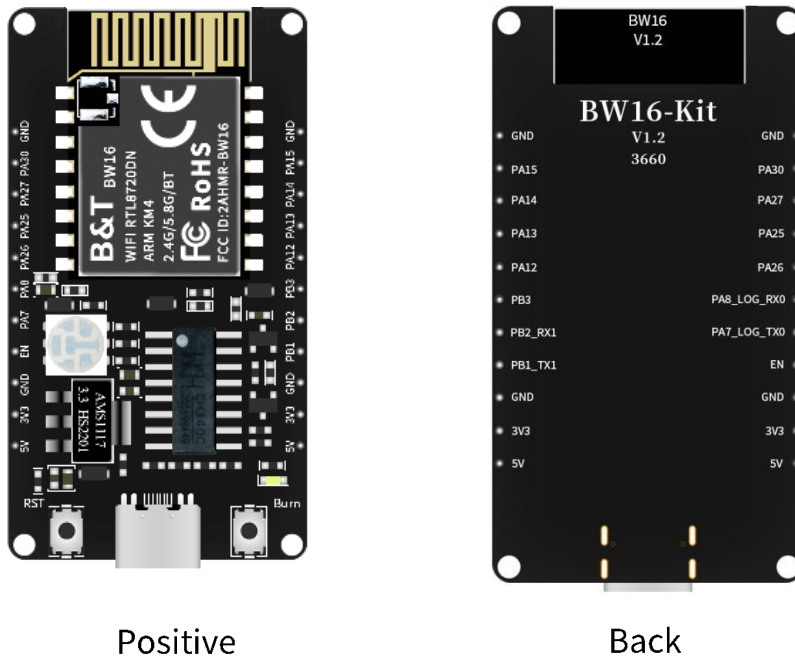

Figure 3 External view of BW16-Kit (For reference only)

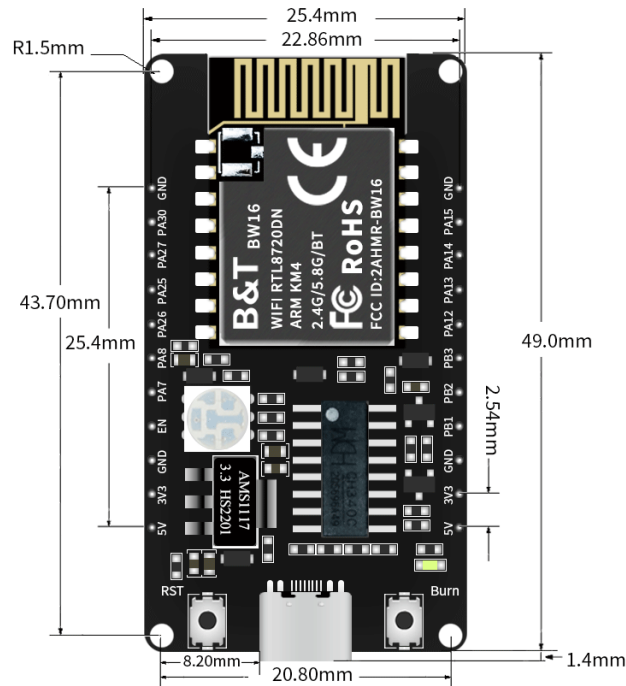

Figure 4 development board size chart

## 4. Indicator light and button description

There is a power indicator light and an RGB light in the BW16-Kit, leading to two buttons: "RST" key and "Burn" key, as shown in the following figure:

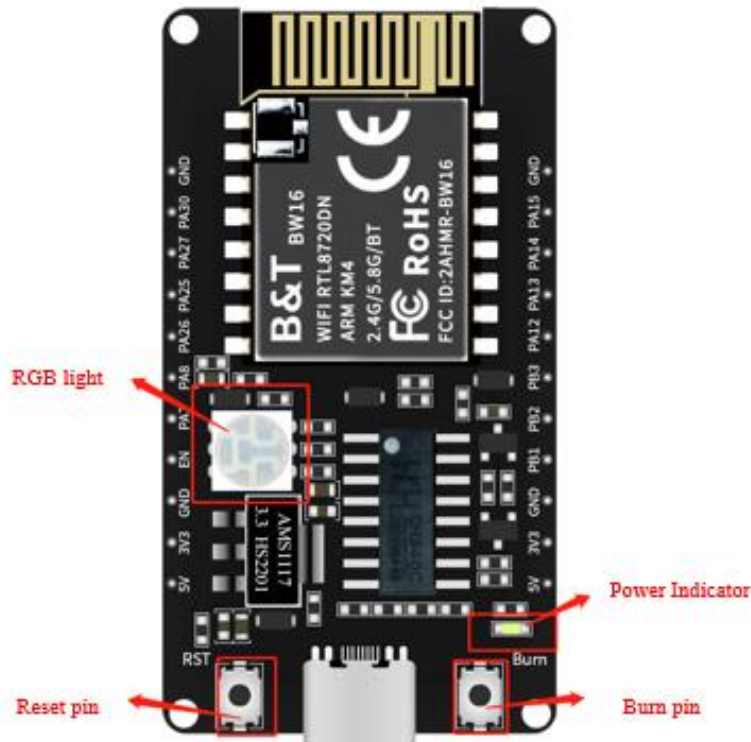

Figure 5 BW16-Kit indicator light and key position

Table 6 indicator status and key function table

Indicator light or button	LED status or button function	Remarks
Power Indicator	5V power indicator	When power is supplied to the development board, the indicator light is on
RGB light	RGB lights are connected to PA12, PA13, PA14 of the Development Board respectively	The three IO pins of RGB lamp correspond to the three primary colors of red, blue and green.
RST key	Reset key	/
Burn key	Set the Development Board to burn mode	Keep press Burn button, then press RTS button and release, finally release Burn button, entering burn mode

## 5. Pin definition

BW16-Kit, 13 interfaces are connected, As shown in the diagram of pins, the pin function definition table is the interface definition.

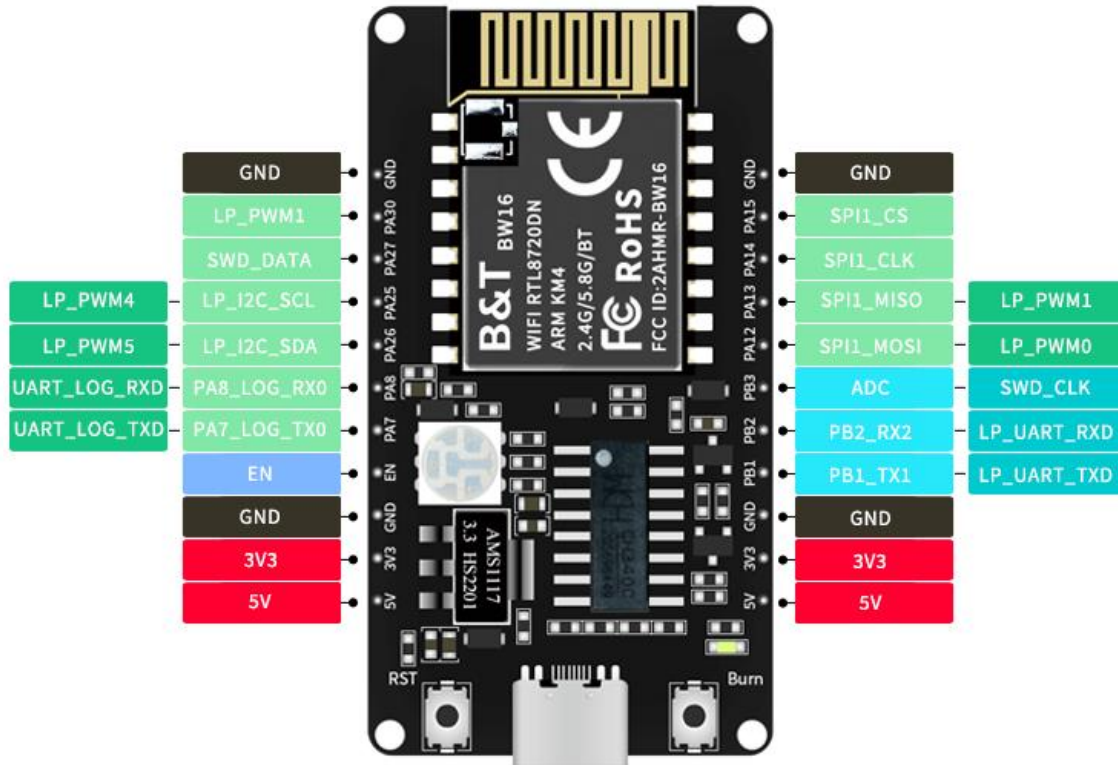

Figure 6 schematic diagram of development board pin

**Table 7 definition table of pin functions**

Foot sequence	Name	Description
1	GND	Conductive earth
2	PA30	LP_PWM1
3	PA27	SWD_DATA
4	PA25	LP_I2C_SCL/LP_PWM4
5	PA26	LP_I2C_SDA/LP_PWM5
6	PA8_LOG_RX0	UART_LOG_RXD
7	PA7_LOG_TX0	UART_LOG_TXD
8	EN	Chip Enable terminal
9	GND	Conductive earth
10	3V3	3.3V power supply
11	5V	5V power supply
12	5V	5V power supply
13	3V3	3.3V power supply
14	GND	Conductive earth
15	PB1_TX1	LP_UART_TXD
16	PB2_RX1	LP_UART_RXD
17	PB3	ADC/SWD_CLK
18	PA12	LP_PWM0/SPI1_MOSI
19	PA13	LP_PWM1/SPI1_MISO
20	PA14	SPI1_CLK
21	PA15	SPI1_CS
22	GND	Conductive earth

## 6. Schematic diagram

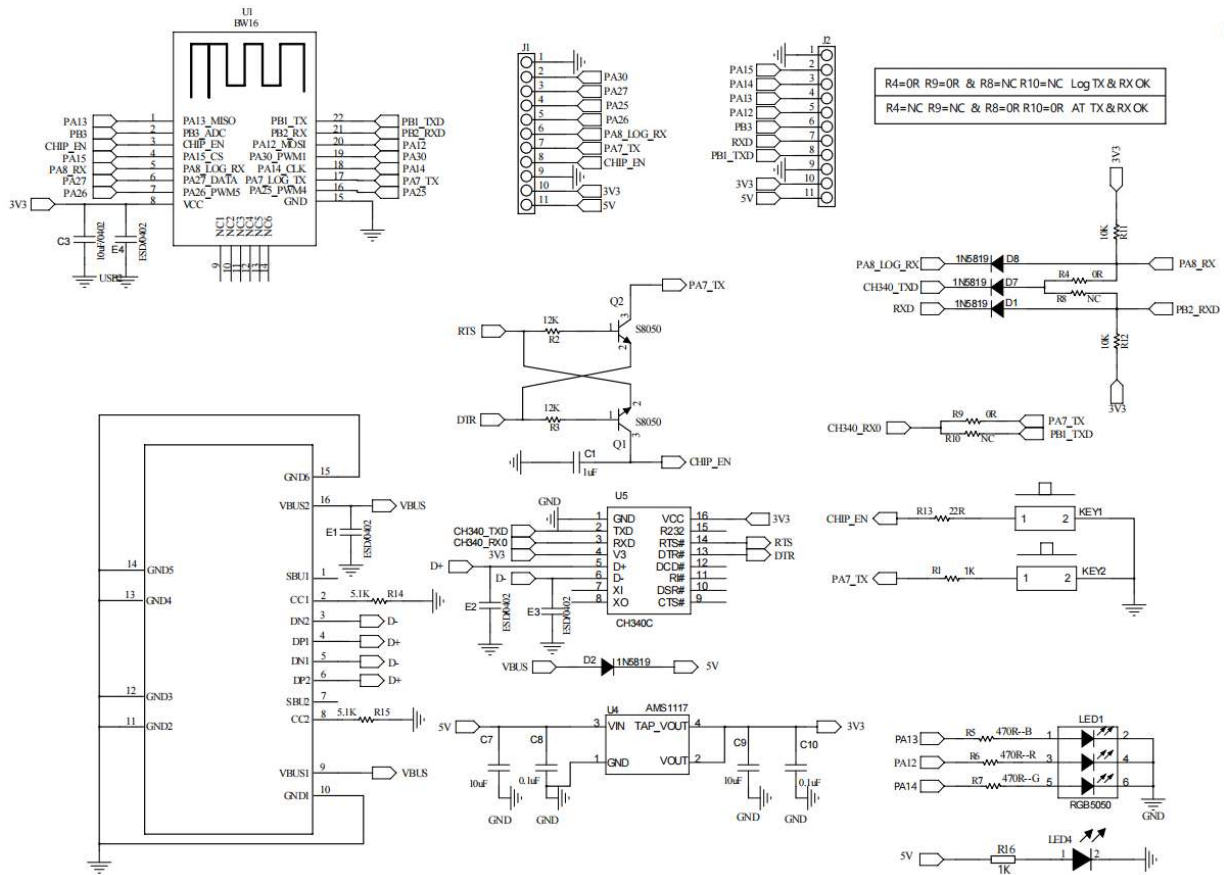

Figure 7 Schematic diagram of Development Board

## 7. Product Related models

Table 8 product related model table

Model	Power supply	Package	Size	Antenna
BW16	3.0V ~ 3.6V, I > 500mA	SMD-16	24*16*3(±0.2)mm	PCB antenna/IPEX seat compatible
BW16-Kit	5V, I > 500mA	DIP-22	50.4*25.4(±0.2)mm	Board-mounted PCB antenna
Product Information: <a href="https://docs.ai-thinker.com">https://docs.ai-thinker.com</a>				

## 8. Product considerations

In BW16-Kit version, the interface Type-C corresponds to serial port 0, and the pins are UART\_LOG\_RXD(PA8\_LOG\_RX0) and UART\_LOG\_TXD(PA7\_LOG\_TX0). The development board can only choose to install new firmware through the Type-C or through the UART\_LOG\_RXD, UART\_LOG\_TXD pin connected to the TTL module to complete the firmware upgrade.

## 9. Product packaging information

Table 9 packing information table

Packing List	Packaging method	Quantity per package (Electrostatic bag)
BW16-Kit	Foam + electrostatic bag	1 piece

## 10. Contact us

[Ai-thinker official website](#)

[Official Forum](#)

[Develop DOCS](#)

[LinkedIn](#)

[Tmall shop](#)

[Taobao shop](#)

[Alibaba shop](#)

[Technical support Email: support@aithinker.com](#)

[Domestic business cooperation: sales@aithinker.com](#)

[Overseas business cooperation: overseas@aithinker.com](#)

Company address: Room 403,408-410, Building C, Huafeng Intelligence Innovation Port, Gushu, Xixiang, Baoan District, Shenzhen.

Tel: 0755-29162996



WeChat mini program



WeChat official account

## Disclaimer and copyright announcement

The information in this article, including the URL for reference, is subject to change without prior notice.

The document is provided "as is" without any guarantee responsibility, including any guarantee for marketability, application for specific purposes or non-infringement, and any guarantee mentioned elsewhere by any proposal, specification or sample. This document is not responsible for any infringement of any patent rights arising from the use of the information in this document. This document does not hereby grant any license for the use of intellectual property rights, either explicitly or implicitly, in a prohibited counterclaim or other way.

The test data obtained in this paper are all obtained by boantong laboratory test, and the actual results may be slightly different.

All trademark names, trademarks and registered trademarks mentioned herein are the property of their respective owners, and hereby declare.

The final right of interpretation belongs to Shenzhen boantong Technology Co., Ltd.

### Note

The content of this manual may be changed due to product version upgrades or other reasons.

Shenzhen boantong Science and Technology Co., Ltd. reserves the right to modify the contents of this manual without any notice or prompt.

This manual is only used as instruction. Shenzhen boantong Science and Technology Co., Ltd. tries its best to provide accurate information in this manual, but Shenzhen boantong Science and Technology Co., Ltd. does not ensure that the contents of this manual are completely correct, and all statements, information and suggestions in this manual do not constitute any express or implied guarantee.