

# OVM6211 400 x 400 product brief

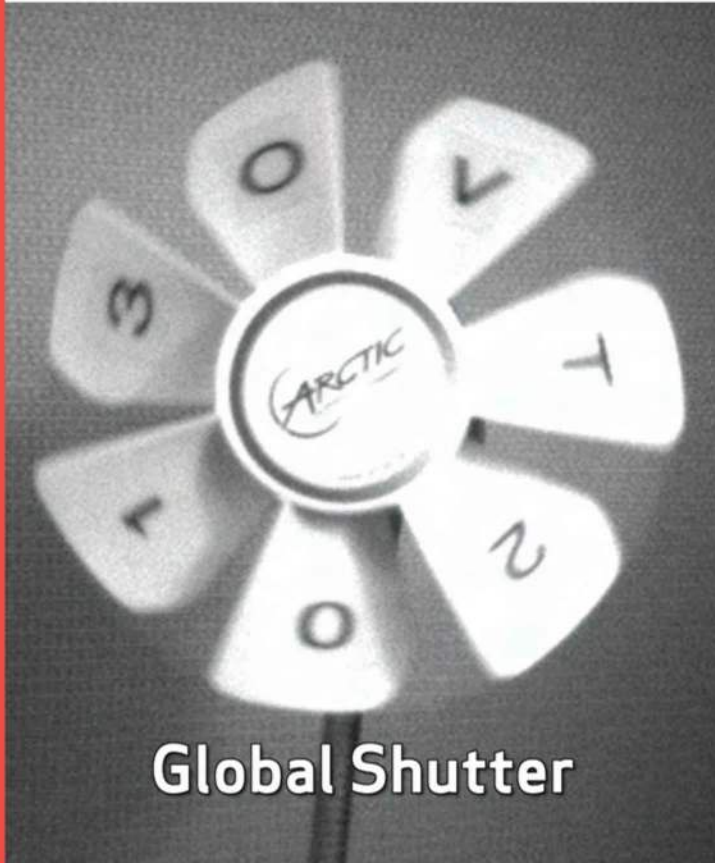

**Global Shutter**

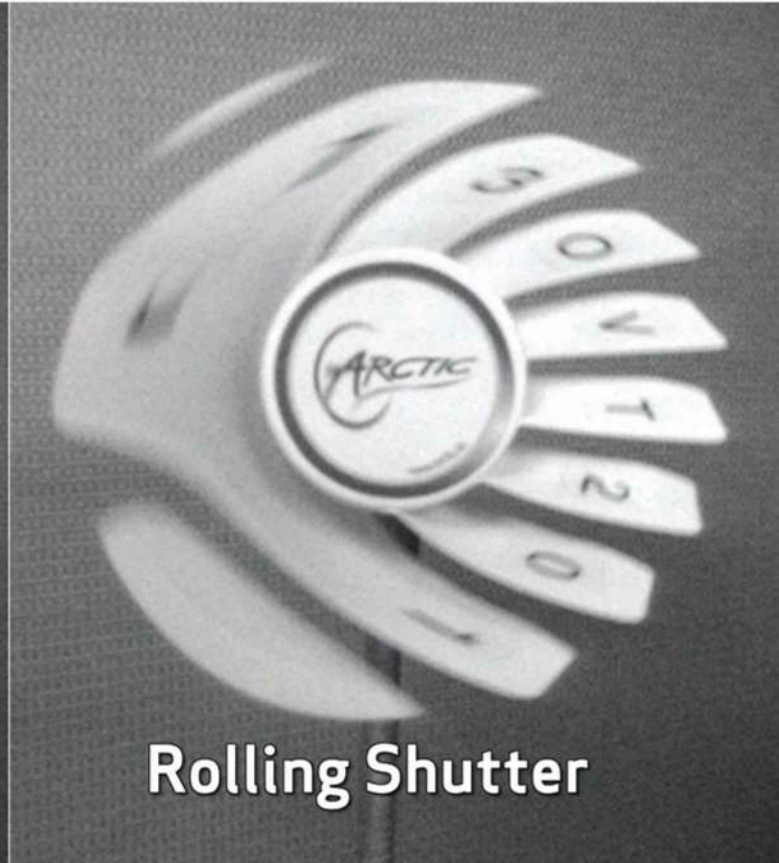

**Rolling Shutter**

## Compact Global Shutter CameraCubeChip™ Brings Computer Vision to Mobile Devices, Notebooks and Wearables



available in  
a lead-free  
package

OmniVision's high performance OVM6211 offers a number of advanced features, including gesture recognition, eye tracking and motion detection in the industry's smallest global shutter package. Its advanced functionality, easy adoption and compact form-factor make it an ideal camera solution for advanced space-constrained devices, such as smartphones, tablets, notebooks and wearables.

Featuring a 3-micron OmniPixel3-GS™ global shutter pixel, the OVM6211 is capable of capturing full resolution (400 x 400 pixels) video at 120 fps and features two low-power modes: light sensing mode and ultra-low power mode.

The OVM6211 CameraCubeChip™ will be available in two packages. The OVM6211-RADA is intended for human interface systems including eye tracking and will have a narrow field of view (FOV) at approximately 50 degrees. The OVM6211-RAHA is a complementary product intended for applications including gesture recognition and wearable devices and uses a lens with FOV wider than 90 degrees.

Find out more at [www.ovt.com](http://www.ovt.com).



## Applications

- Eye Tracking
- Security and Surveillance
- Wearable Devices
- Toys and Games

## Product Features

- 3  $\mu\text{m}$  global shutter pixel
- programmable SCCB device ID
- automatic black level calibration (ABLC)
- one-lane MIPI serial output interface
- programmable controls for:
  - frame rate
  - mirror and flip
  - cropping
  - windowing
- embedded 128 bits of one-time programmable (OTP) memory for part identification, etc.
- two on-chip phase lock loop (PLL)
- supports output formats: 8/10-bit RAW
- programmable I/O drive capability
- supports images sizes:
  - 400 x 400
  - 200 x 200
  - 100 x 100
- built-in 1.5V regulator for core
- PWM
- fast mode switching
- built-in strobe control
- supports horizontal and vertical 2:1 and 4:1 monochrome subsampling
- ultra low power mode for ambient light sensor
- supports 2x2 monochrome binning
- standard serial SCCB interface

# OVM6211

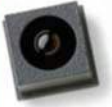

## Ordering Information

- **OVM6211-RADA** (B&W, lead-free) CameraCubeChip™ with black coating, 50° FOV
- **OVM6211-RAHA** (B&W, lead-free) CameraCubeChip™ with black coating, 90° FOV

## Product Specifications

- **active array size:** 400 x 400
- **max S/N ratio:** 37.5 dB
- **power supply:**
  - core: 1.5 VDC  $\pm$ 5%
  - analog: 2.6 - 3.0V
  - I/O: 1.7 - 3.0V
- **dynamic range:** 66.5 dB @ 8x gain
- **power requirements:**
  - active: 85 mW @ 120 fps
  - standby: 15  $\mu\text{A}$  for AVDD, 40/700  $\mu\text{A}$  for DOVDD with/without input clock
  - XSHUTDOWN: 5  $\mu\text{A}$  for AVDD, 5  $\mu\text{A}$  for DOVDD
- **maximum image transfer rate:**
  - 400 x 400: 120 fps
  - 200 x 200: 220 fps
  - 100 x 100: 380 fps
- **temperature range:**
  - operating: -30°C to +70°C junction temperature
  - stable image: 0°C to +50°C junction temperature
- **sensitivity:** 7190 mV/( $\mu\text{W}\cdot\text{cm}^2\cdot\text{sec}$ ) @ 850 nm  
2800 mV/Lux-sec @ 530 nm
- **scan mode:** progressive
- **output formats:** 8/10-bit RAW
- **maximum exposure interval:** 434 x  $t_{\text{row}}$
- **optical format:** 1/10.5"
- **pixel size:** 3  $\mu\text{m}$  x 3  $\mu\text{m}$
- **input clock frequency:** 6 - 27 MHz
- **dark current:** 2000 e<sup>-</sup>/s @ 50°C junction temperature
- **f no.:**
  - RADA: 3.1
  - RAHA: 2.4
- **image area:** 1248  $\mu\text{m}$  x 1248  $\mu\text{m}$
- **focal length:**
  - RADA: 1.681 mm
  - RAHA: 0.776 mm
- **net weight:**
  - RADA: 38.1 mg
  - RAHA: 59.9 mg
- **package dimensions (including ball height):**
  - RADA: 3230 x 3230 x 2450  $\mu\text{m}$
  - RAHA: 3230 x 3230 x 3920  $\mu\text{m}$

## Functional Block Diagram

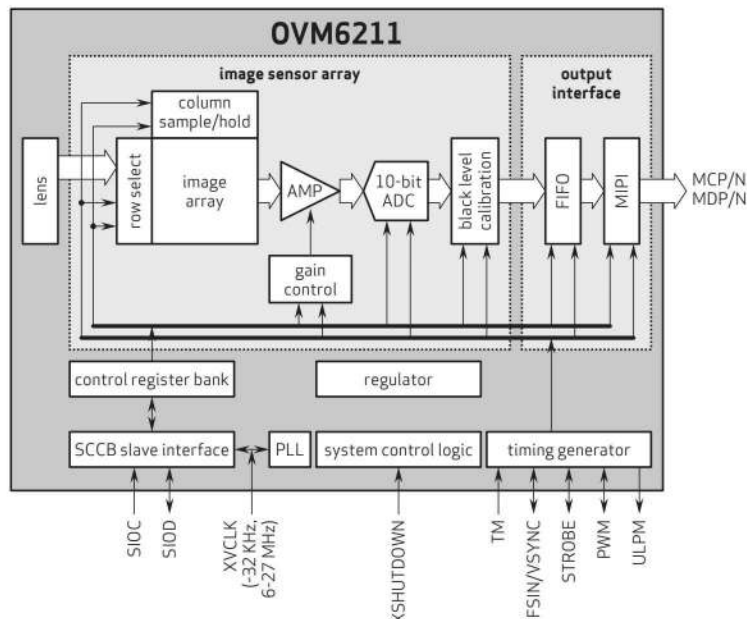

4275 Burton Drive  
Santa Clara, CA 95054  
USA

Tel: +1 408 567 3000  
Fax: +1 408 567 3001  
www.ovt.com

OmniVision reserves the right to make changes to their products or to discontinue any product or service without further notice. OmniVision and the OmniVision logo are registered trademarks of OmniVision Technologies, Inc. CameraCubeChip and OmniPixel3-G5 are trademarks of OmniVision Technologies, Inc. All other trademarks are the property of their respective owners.



OmniVision