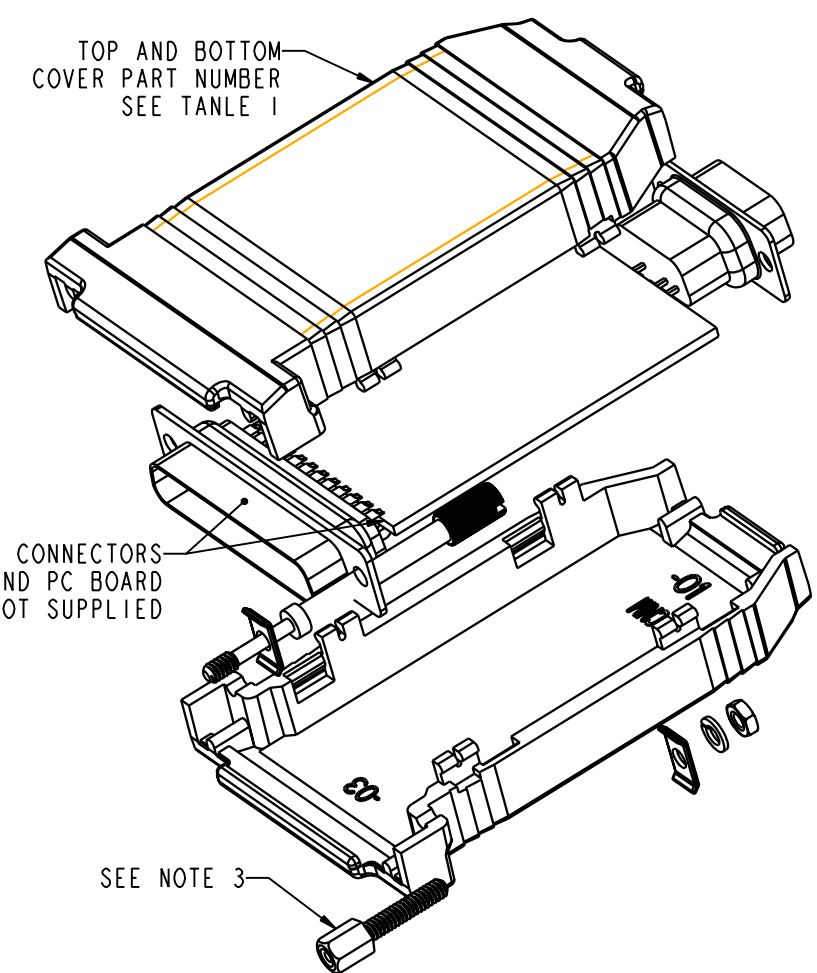
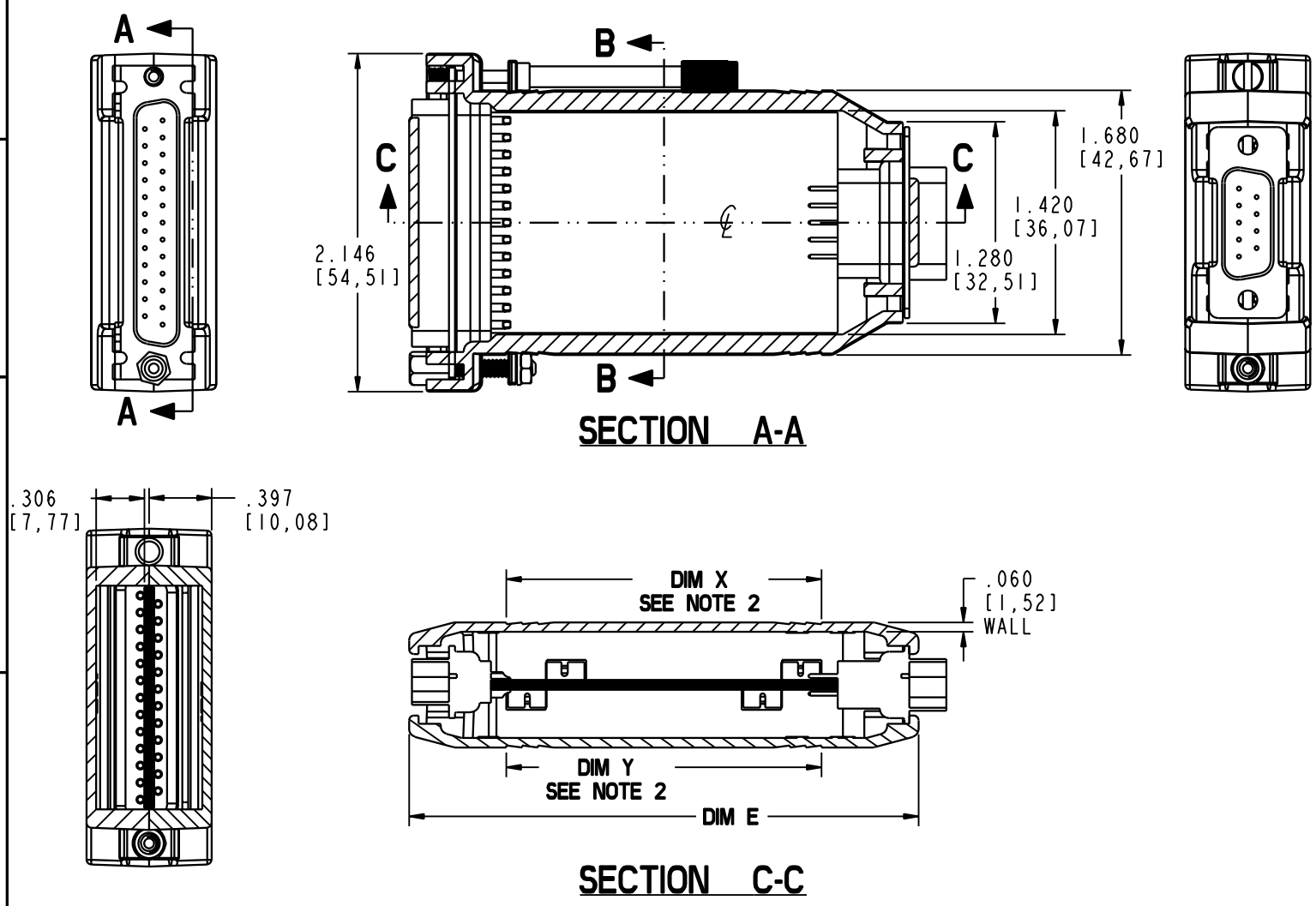
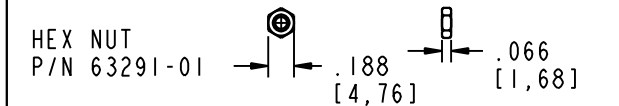
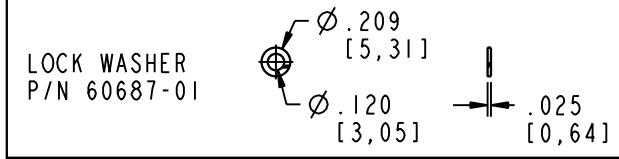
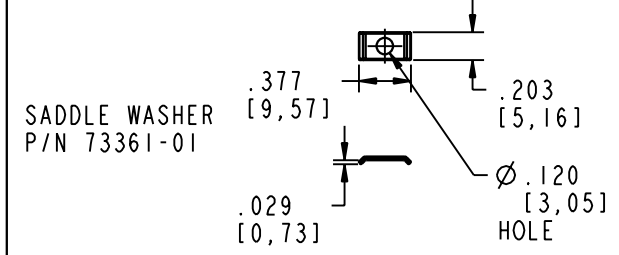
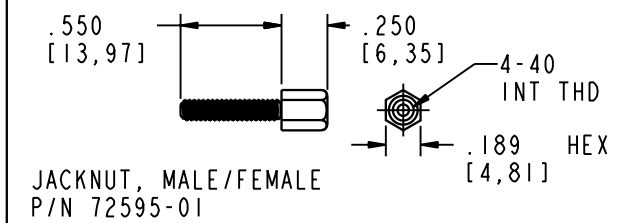
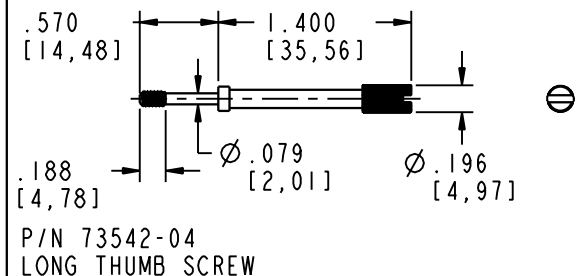
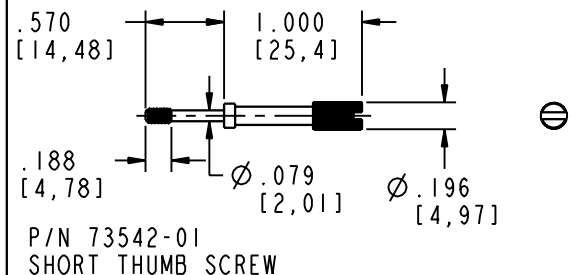
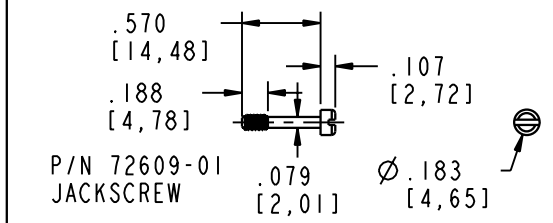

TABLE 2

ALL HARDWARE IS 4-40, ALL SCREWS AND THUMB SCREWS ARE CAPTIVE. THE JACK NUT IS NOT CAPTIVE AND THIS ITEM CAN BE THREADED INTO THE HOUSING, OR THE HOLE CAN BE ENLARGED.



- NOTES:
1. ACTUAL PCB LENGTH IS A PRODUCT OF THE CONNECTORS SELECTED.
 2. DIM X & Y ARE TOP AND BOTTOM COVER INSERT AREA X 1.450 [36,83] WIDE.
 3. HARDWARE TO BE ORDERED SEPARATE FROM TABLE 2 PER CUSTOMER SPECIFIC REQUIREMENTS.

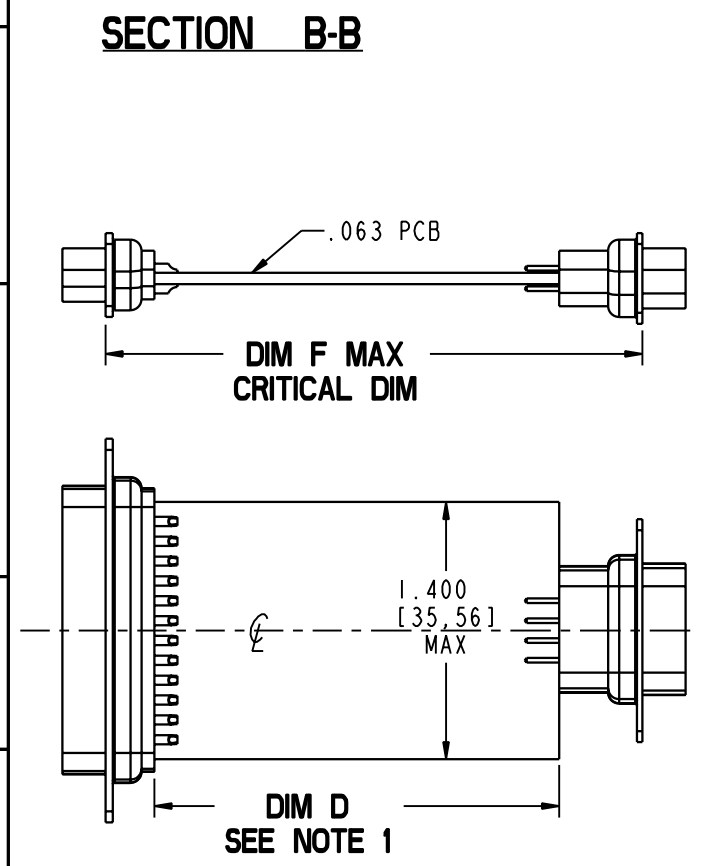

TABLE 1

CN SIZE	S	M	L
HOUSING PART NUMBER	CNS-0103	CNM-0103	CNL-0103
DIM D PCB SIZE	SEE NOTE 1		
DIM E OVERALL SIZE	2.734 [69,44]	3.234 [82,14]	3.734 [94,84]
DIM F MAX CRITICAL DIM	2.610 [66,29]	3.110 [79,01]	3.610 [91,69]
DIM X & Y INSERT AREA	1.500 [38,10]	2.000 [50,80]	2.500 [63,50]

DB9 STRAIGHT CONNECTOR TO DB25 STRAIGHT CONNECTOR

PACINTEC[®]
1-610-361-4231

CN-0103-SERIES
SEE TABLE 1

VISIT **PACINTEC**[®]
ON THE WORLD WIDE WEB
www.pactecenclosures.com

COLOR / MATERIAL CODE		
COLOR	94HB	94VO
BLACK	000	028
P. C. BONE	039	060