

“Zero Height” SiSonic™ Microphone Specification

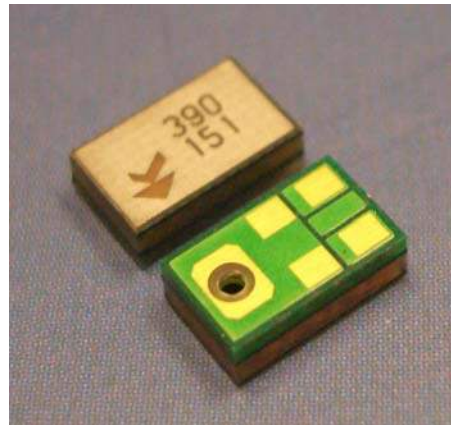

Knowles Acoustics
1151 Maplewood Drive
Itasca, IL 60143

1. DESCRIPTION AND APPLICATION

1.1 Description

Zero Height Surface Mount Silicon Microphone

1.2 Application

Hand held telecommunication devices

2. PART MARKING

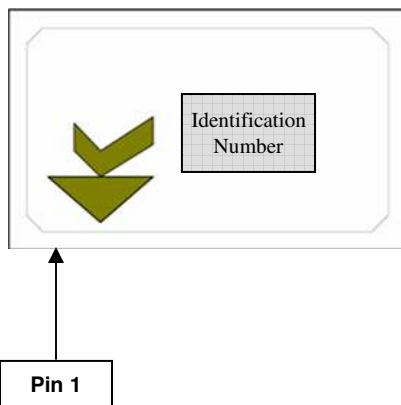

Identification Number Convention

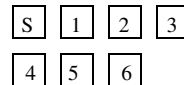

S: Manufacturing Location

“S” – Knowles Electronics Suzhou
Suzhou, China

“No Alpha Character” – Knowles Electronics Itasca
Itasca, IL USA

“E” – Engineering Samples

Digits 1 – 6: Job Identification Number

3. TEMPERATURE RANGE

3.1 Operating Temperature Range: -40°C to +100°C

3.2 Storage Temperature Range: -40°C to +100°C

4. ACOUSTIC & ELECTRICAL SPECIFICATIONS

Test Conditions: +20°C, 60-70% R.H.

	Symbol	Condition	Limits			Unit
			Min.	Nom.	Max.	
Directivity		Omni-directional				
Sensitivity	S	@ 1kHz (0dB=1V/Pa)	-46	-42	-38	dB
Output impedance	Z _{OUT}	@ 1kHz (0dB=1V/Pa)	n/a	n/a	100	Ω
Current Consumption	I _{DSS}	across 1.5 to 5.5 volts	0.100	n/a	0.250	mA
Signal to Noise Ratio	S/N	@ 1kHz (0dB=1V/Pa)	55	59	n/a	dB
Supply Voltage	V _s		1.5	n/a	5.5	V
Typical Input Referred Noise	ENL	A-weighted	n/a	35	n/a	dBa SPL
Sensitivity Loss across Voltage		Change in sensitivity over 5.5v to 1.5v	No Change Across Voltage Range			dB
Maximum Input Sound Level		At 100dB SPL, THD < 1% At 115dB SPL, THD = < 10%				dB
Contact Resistance					100	Ohms

5. FREQUENCY RESPONSE CURVE

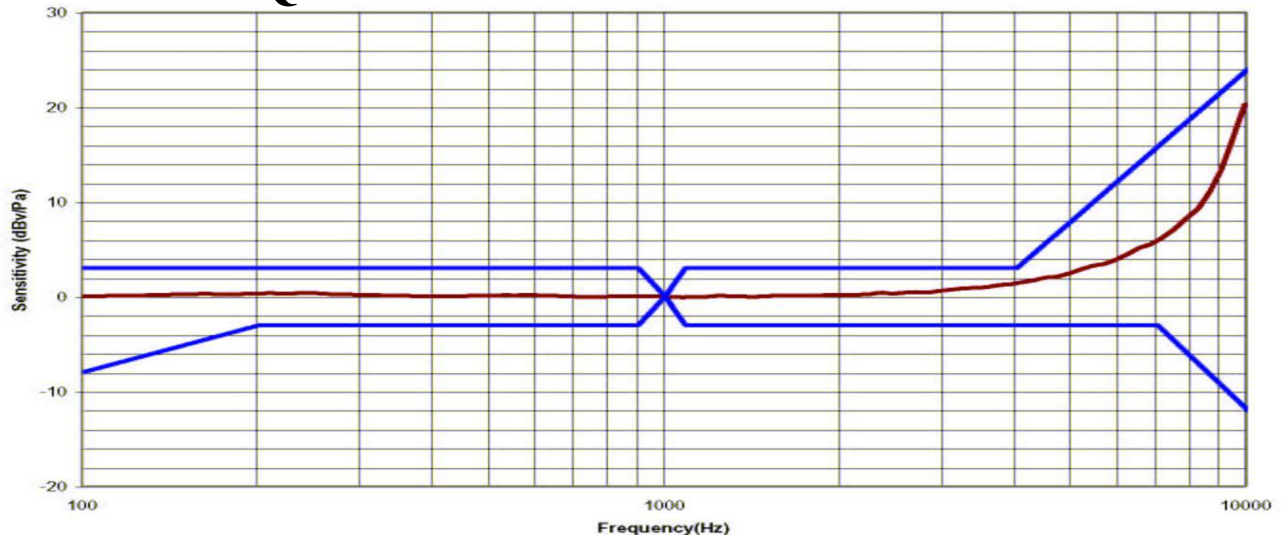

6. MECHANICAL SPECIFICATIONS

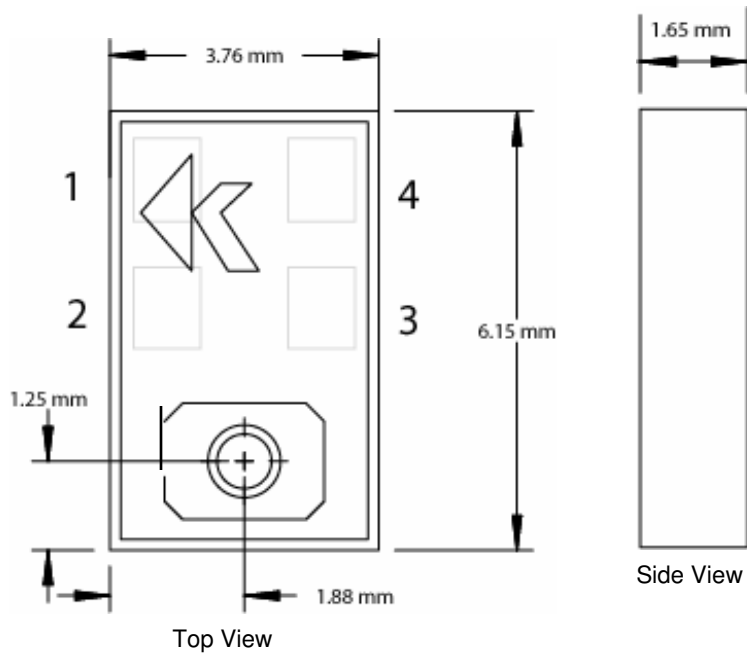

Item	Dim.	Tol. (+/-)	Units
Height	1.65	+0.20 -0.10	mm
Length	6.15	0.10	mm
Width	3.76	0.10	mm
Weight	0.09		grams
Coplanarity	< 0.1		mm

Pin Output	
Pin #	Function
1	Output
2	Ground
3	Ground
4	Power

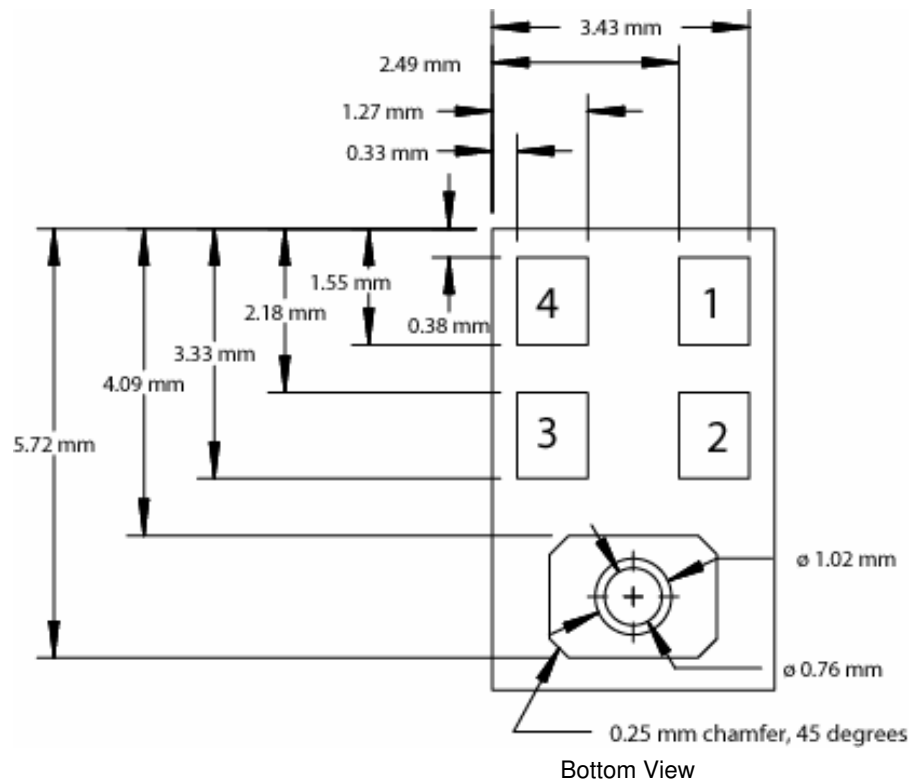

(Note: Tolerance +/-0.15mm unless otherwise specified)

7. RECOMMENDED CUSTOMER LAND PATTERN

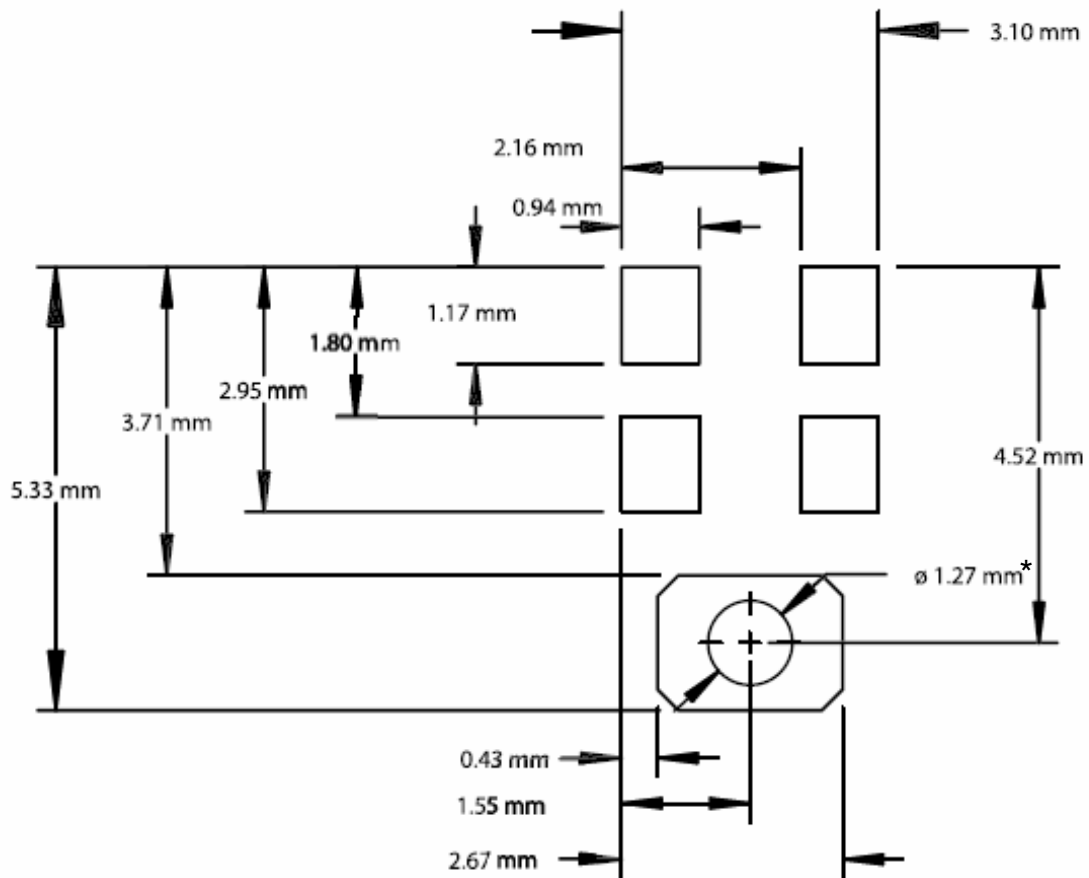

* Note: Minimum PCB Hole Diameter: 1.02 mm

8. RECOMMENDED SOLDER STENCIL PATTERN

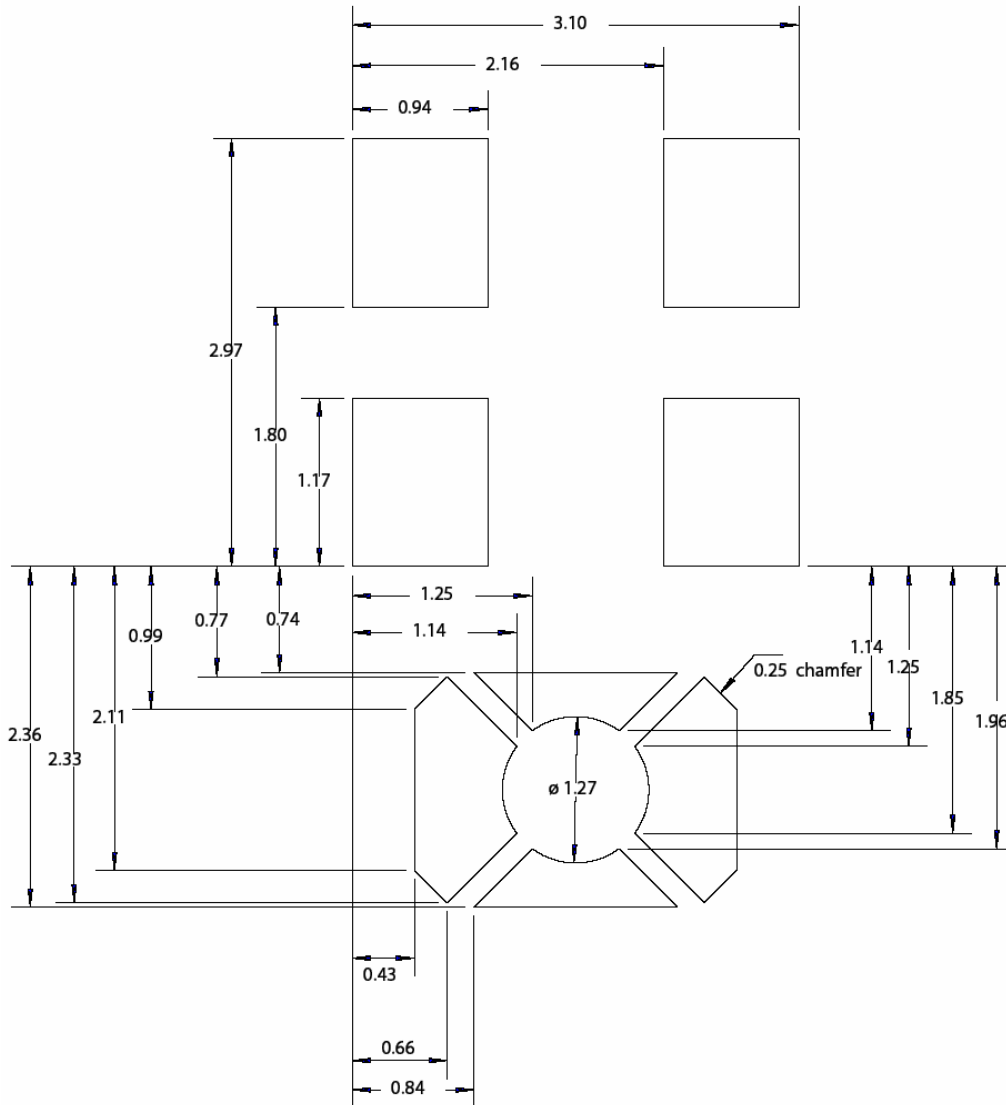

Notes:

- The design requires that an acoustic seal be established between the SiSonic and customer PCB. This is accomplished via a solder seal.
- Solder Stencil Thickness = 0.127 min to 0.178 max
- Stencil Material = Stainless Steel

9. RECOMMENDED INTERFACE CIRCUIT

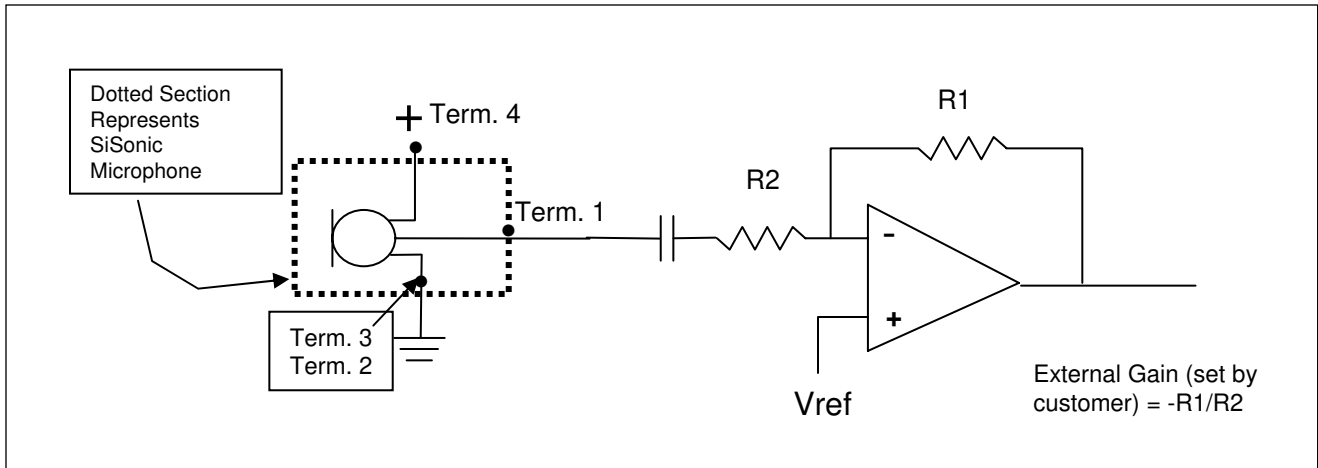

10. PACKAGING DETAIL

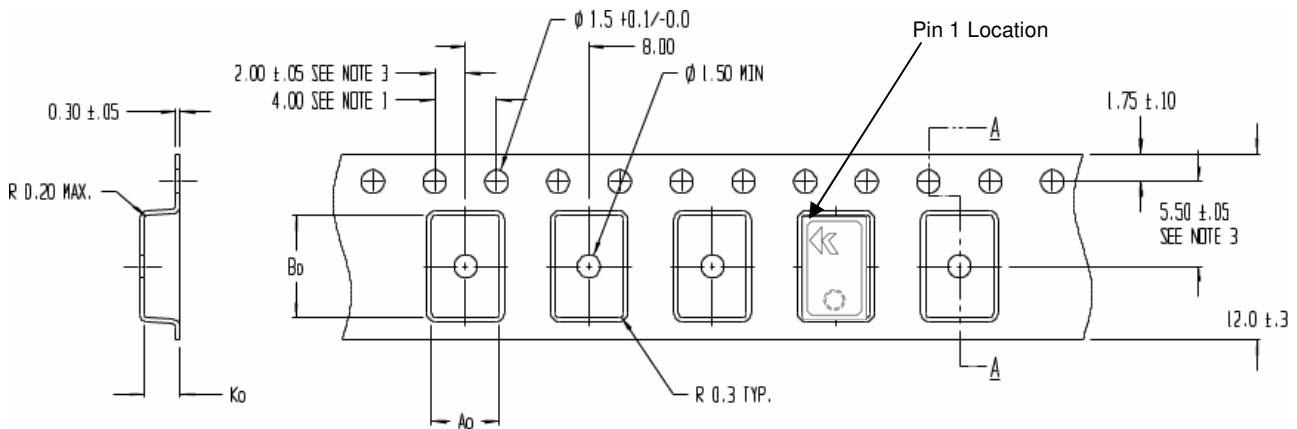

SECTION A - A

$A_0 = 4.40$
 $B_0 = 6.60$
 $K_0 = 2.30$

NOTES:

1. 10 SPROCKET HOLE PITCH CUMULATIVE TOLERANCE ± 0.2
2. CAMBER IN COMPLIANCE WITH EIA 481
3. POCKET POSITION RELATIVE TO SPROCKET HOLE MEASURED AS TRUE POSITION OF POCKET, NOT POCKET HOLE

Model Number	Suffix	Reel Diameter	Qty per Reel
SP0102BE3	-5	7"	900
SP0102BE3	-4	13"	3,600

Tape & Reel	Available in 13" and 7" diameter.
Leader Length	800mm or minimum of 100 empty pockets
Label	Label applied to external package and direct to reel. Per JEDEC.
Empty Units	No consecutive empty pockets; No more than 3 empty pockets per reel. (Does not include empty pockets for leader/follower)

11. SOLDER REFLOW PROFILE

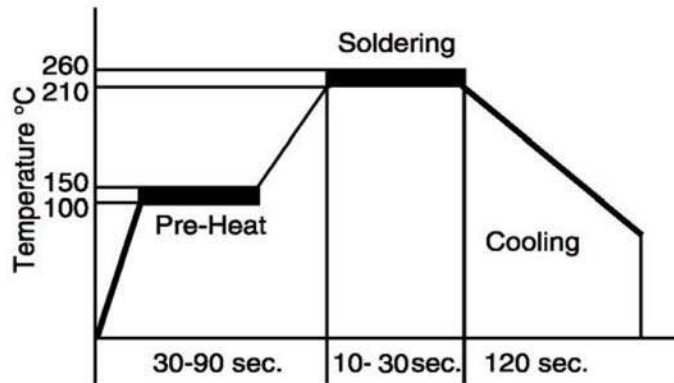

Notes:

1. Maximum condition = 260 C for 30 seconds.
2. Do not pull a vacuum over the port hole of the microphone. Pulling a vacuum over the port hole can damage the device.
3. Do not board wash after the reflow process. Board washing and cleaning agents can damage the device. Do not expose to ultrasonic processing or cleaning.
4. Number of Reflow = recommend no more than 2 cycles.

12. ADDITIONAL NOTES

- (A) Packaging (reference SiSonic_Packaging_Spec.pdf)
- (B) Shelf life: Twelve (12) months when devices are to be stored in factory supplied, unopened moisture sensitivity bag under environmental conditions of 30°C, 60% R.H.
- (C) Exposure: Devices should not be exposed to high humidity, high temperature environment. Customer should follow standard baking times as stated in JEDEC J-STD-033A, reference Class 2A.
 Out of bag: 90 days out of ESD moisture sensitive bag, assuming 30C/60% RH as maximum.
 Baking Condition: After 90 days, recommend baking at 90°C (<5% RH) for 48 hours. (for optional times and temperatures, refer to JEDEC J-STD-033A.

13. RELIABILITY SPECIFICATIONS

Note: After test conditions are performed, the sensitivity of the microphone shall not deviate more than 3dB from its initial value.

Test	Description
Thermal Shock	Microphone unit must operate when exposed to air-to-air thermal shock 100 cycles, from -40°C to $+125^{\circ}\text{C}$. (IEC 68-2-4),
High Temperature Storage Test	Microphone unit must maintain sensitivity after storage at $+105^{\circ}\text{C}$ for 1,000 hours. (IEC 68-2-2 Test Ba)
Low Temperature Storage Test	Microphone unit must maintain sensitivity after storage at -40°C for 1,000 hours. (IEC 68-2-1 Test Aa)
High Temperature Operating Test	Microphone unit must operate within sensitivity specifications for 1,000 hours at 105°C . (IEC 68-2-2 Test Ba)
Low Temperature Operating Test	Microphone unit must operate within sensitivity specifications for 1,000 hours at -40°C . (IEC 68-2-1 Test Aa)
Humidity Test	Tested under Bias at $85^{\circ}\text{C}/85\%$ R.H. for 1,000 hours. (JESD22-A101A-B)
Vibration Test	Microphone unit must operate under test condition: 4 cycles, from 20 to 2,000 Hz in each direction (x,y,z), 48 minutes, using peak acceleration of 20 G (+20%, -0%). (MIL 883E, method 2007.2, A)
Electrostatic Discharge	Tested to 8kV direct contact discharge or 15kV air discharge as specified by IEC 1000-4-2, level 3 and level 4.
Reflow	Microphone is tested to 5 passes through reflow oven, with microphone mounted upside-down under conditions of 260°C for 30 seconds maximum.
Mechanical Shock	Microphone must operate after exposure to shock test of 10,000 G per IEC 68-2-27, Ea.

14. SPECIFICATION REVISIONS

Revision	Detailed Specification Changes	Date
A	Initial Release	12-1-04