

NOTES:

- 1. MATERIALS AND FINISHES:
 BODY, REAR BODY, WASHER & HEX NUT - BRASS, NICKEL PLATING
 CONTACT - BeCu, SILVER PLATING
 INSULATORS - PTFE, NATURAL
 GASKET - RUBBER, BLACK
 GASKET - SILICONE RUBBER, RED
- 2. ELECTRICAL
 IMPEDANCE: 50 OHM.

- 3. MECHANICAL:
 A. DURABILITY: 500 CYCLES MIN.
 B. TEMPERATURE RANGE: -65° C TO +165° C
- 4. PACKAGING:
 A. QUANTITY: SINGLE PACK
 B. MARKING: BAG TO BE MARKED
 "AMPHENOL RF, 11050, AND DATE CODE"

THIRD ANGLE PROJ.

REVISIONS

REV	DESCRIPTION	DATE	ECO	APPR
--	RELEASE TO MFG.	--	--	--
M	REDRAWN IN PRO-E & COD SHEET ADDED	6/1/15	50343	NR

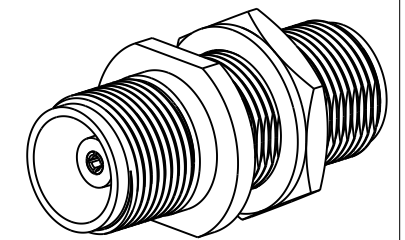

SCALE 1.000

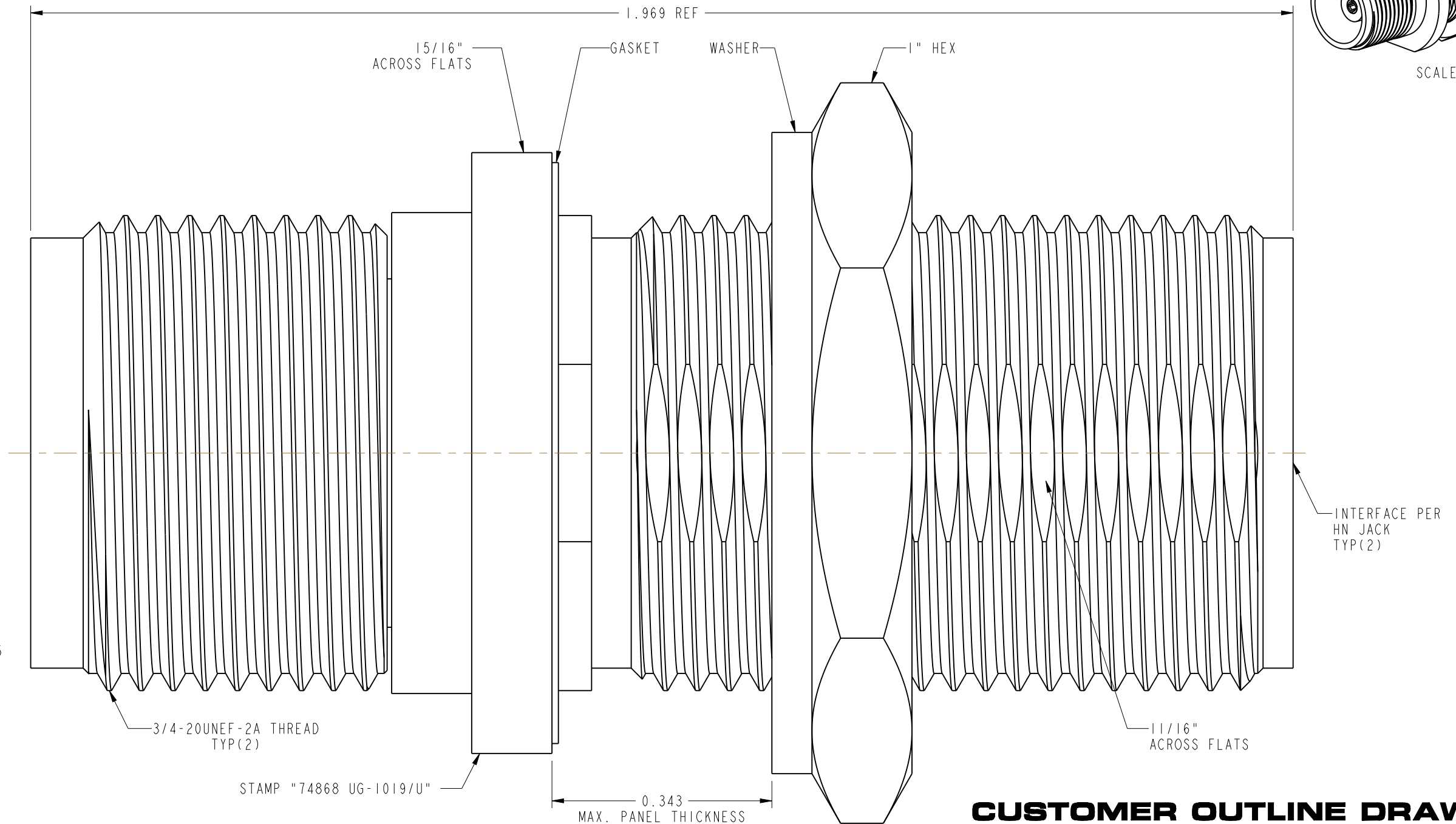
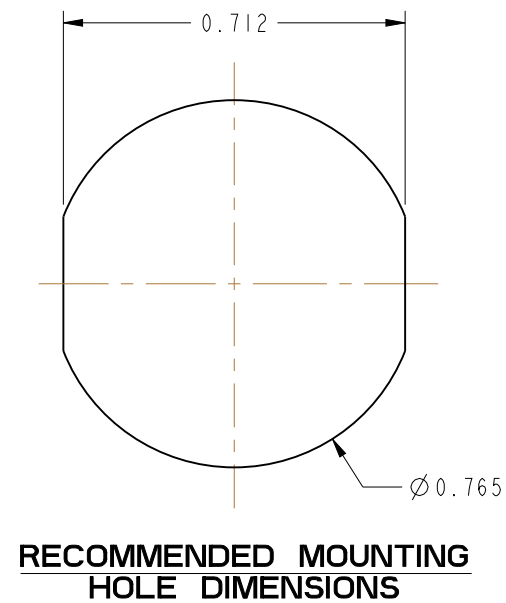

CUSTOMER OUTLINE DRAWING
 ALL OTHER SHEETS ARE FOR INTERNAL USE ONLY

UNLESS OTHERWISE SPECIFIED, DIMENSIONS ARE IN INCHES AND TOLERANCES ARE: 2 PLACE DECIMAL 3 PLACE DECIMAL ANGLES ±.015 (0,381 mm) ±.005 (0,127 mm) ± 1°	MATERIAL	DRAWN	DATE	TITLE		Amphenol RF www.amphenolrf.com
	SEE NOTES	RAJAGOPAL N	13-Jan-15	HN STR BHD JACK FEED-THRU ADAPTER PRESSURIZED UG-1019/U		
NOTICE - These drawings, specifications, or other data (1) are, and remain the property of Amphenol corp. (2) must be returned upon request; and (3) are confidential and not to be disclosed to any person other than those to whom they are given by Amphenol Corp. the furnishing of these drawings, specifications, or other data by Amphenol Corp., or to any other person to anyone for any purpose is not to be regarded by implication or otherwise in any manner licensing, granting rights to permitting such holder or any other person to manufacture, use or sell any product, process or design, patented or otherwise, that may in any way be related to or disclosed by said drawings, specifications, or other data.	REFERENCE	ENGINEER	DATE	SCALE: 5.5:1.0 SHEET 2 OF 2		DRAWING NO. 11050
	CANNON 052011-0001 DOR 51-216051 CONFIGURATION LEVEL: In Work	K. CAPOZZI	13-Jan-15	DWG SIZE B REV M		ITEM NO. 11050
	FINISH	APPROVED	DATE	PART NO. 11050		
		K. CAPOZZI	6/1/15			
		CAD FILE				