

REVISIONS					
P	LTR	DESCRIPTION	DATE	DWN	APVD
	G	REVISED PER ECN-22-139591	19JUL2022	AK	SZ

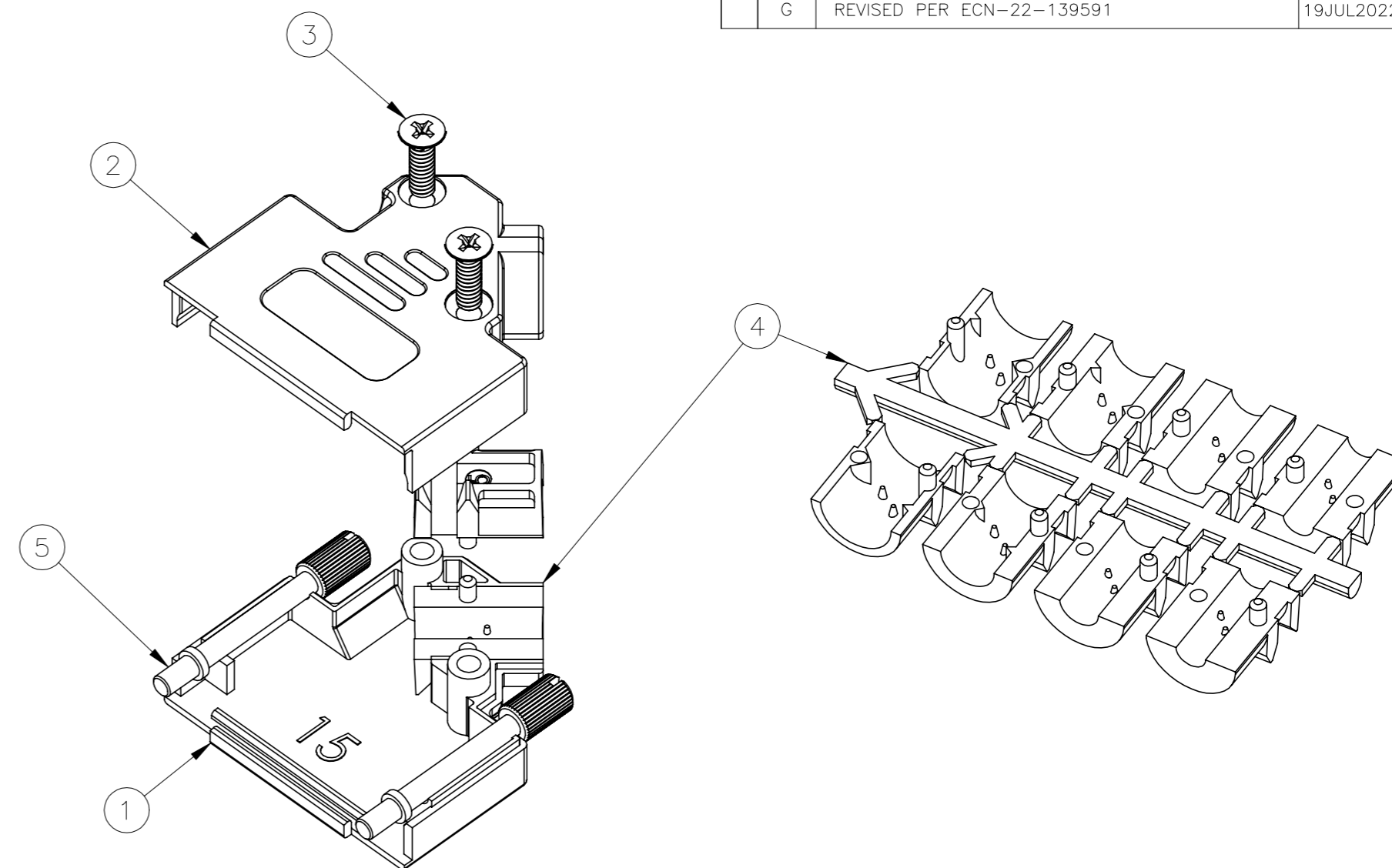
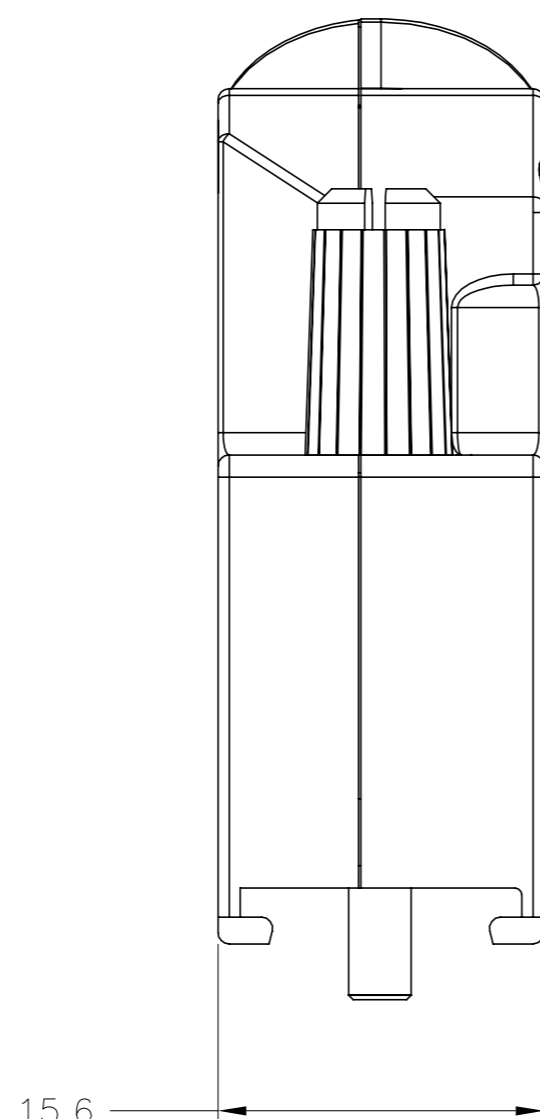
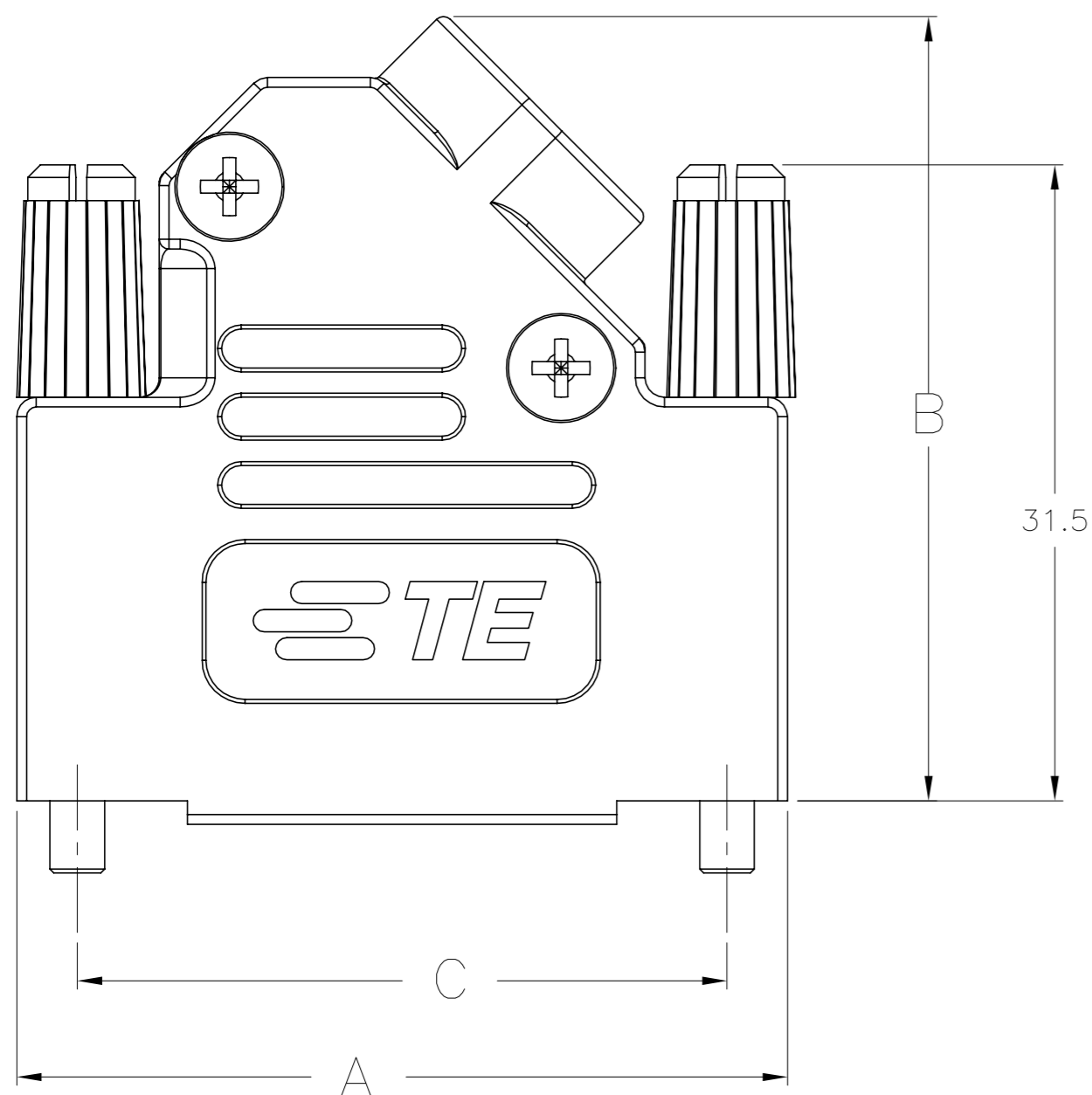

- 7 JACKSCREW QUANTITY:
 9 WAY ASSEMBLY: 1 JACKSCREW
 15 WAY ASSEMBLY: 2 JACKSCREWS
 25 WAY ASSEMBLY: 2 JACKSCREWS
 37 WAY ASSEMBLY: 2 JACKSCREWS.

OPTIONAL CABLE CRIMP KIT AVAILABLE FOR
 8. 6.0-9.5 DIAMETER CABLE. SEE 1478764.

1. FOR ASSEMBLY DETAILS, REFER TO LEAFLET 2227518-1.

2 BULK PACKAGED BACKSHELL ASSEMBLIES: ITEMS 1 THRU 5, 100 TIMES QTY SHOWN IN TABLE IN 1 BAG FOR EACH ITEM. ALL BAGS IN 1 BOX WITH (1) 2227518-1 LEAFLET.

3 INDIVIDUALLY PACKAGED SHELL ASSEMBLIES: 1 BAG CONTAINS ALL COMPONENTS FOR 1 COMPLETE ASSEMBLY. 100 BAGS PER BOX, (1) 2227518-1 LEAFLET PER BOX.

4. TERMINATES 4.0-13.0 CABLE DIAMETERS.

5. 15 POSITION SHOWN.

6 TRIVALENT CHROMIUM CHROMATE COATING OVER ZINC PLATING.

SUPERSEDED BY 5-1478763-4	3	63.5	40.2	69.5	PHILLIPS	4-40 UNC	4	37 WAY	5-2198618-4
SUPERSEDED BY 5-1478763-3	3	47.0	40.2	53.0	PHILLIPS	4-40 UNC	3	25 WAY	5-2198618-3
SUPERSEDED BY 5-1478763-2	3	33.3	40.2	39.3	PHILLIPS	4-40 UNC	2	15 WAY	5-2198618-2
SUPERSEDED BY 2198618-9	3	25.0	36.2	31.0	PHILLIPS	4-40 UNC	1	9 WAY	5-2198618-1
	2	63.5	40.2	69.5	PHILLIPS	4-40 UNC	4	37 WAY	3-2198618-7
	2	47.0	40.2	53.0	PHILLIPS	4-40 UNC	3	25 WAY	2-2198618-5
	2	33.3	40.2	39.3	PHILLIPS	4-40 UNC	2	15 WAY	1-2198618-5
	2	25.0	36.2	31.0	PHILLIPS	4-40 UNC	1	9 WAY	2198618-9
PACKAGING		C	B	A	SELF TAPPING FIXING SCREW TYPE	JACKSCREW THREAD	SHELL SIZE	POSITION	PART NUMBER

5	JACKSCREW ASSEMBLY, 4-40	POLYAMIDE, UL94 V2 KNOB	BLACK	7
		CARBON STEEL SHAFT	6	
4	STRAIN RELIEF SET	POLYCARBONATE UL94 V0	BLACK	1
3	SELF TAPPING FIXING SCREW	CARBON STEEL	6	2
2	TOP BACKSHELL	ABS UL94 V0	NICKEL	1
1	BOTTOM BACKSHELL	ABS UL94 V0	NICKEL	1
ITEM	DESCRIPTION	MATERIAL	FINISH	QTY

THIS DRAWING IS A CONTROLLED DOCUMENT. DIMENSIONING AND TOLERANCING PER ASME Y14.5M-2009

DIMENSIONS: mm	TOLERANCES UNLESS OTHERWISE SPECIFIED:	DWN C. VALENTINE 09DEC2011	TE Connectivity
0 PLC ± 0.5	1 PLC ± 0.5	CHK C. ROHDE 08DEC2011	
2 PLC ± 0.5	3 PLC ± 0.5	APVD C. ROHDE 08DEC2011	NAME
4 PLC ± 0.5	ANGLES ± 0.5°	PRODUCT SPEC	SHEILED PLASTIC BACKSHELL 45 DEGREE ENTRY
MATERIAL SEE TABLE	FINISH SEE TABLE	APPLICATION SPEC	SIZE CAGE CODE DRAWING NO RESTRICTED TO
		WEIGHT 0.000000	A2 00779 C=2198618
		CUSTOMER DRAWING	SCALE 1:1 SHEET 1 of 1 REV G