

THIS DRAWING CONTAINS INFORMATION PROPRIETARY TO RF INDUSTRIES,
 ANY UNAUTHORIZED USE OF THIS DRAWING IS EXPRESSLY PROHIBITED
 WITHOUT WRITTEN PERMISSION FROM RF INDUSTRIES.
 ANY VIOLATION IS PUNISHABLE UNDER U.S. COPYRIGHT LAWS.

ALL DIMENSIONS ARE REFERENCE ONLY

PART NO.		RP-3252-1C		
REV	DESCRIPTION	DWN	DATE	APPROVED
-	ENGINEERING RELEASE	CZS	8/21/02	JDMc
A	ADD HARDWARE IMAGES	CZS	6/27/05	JDMc

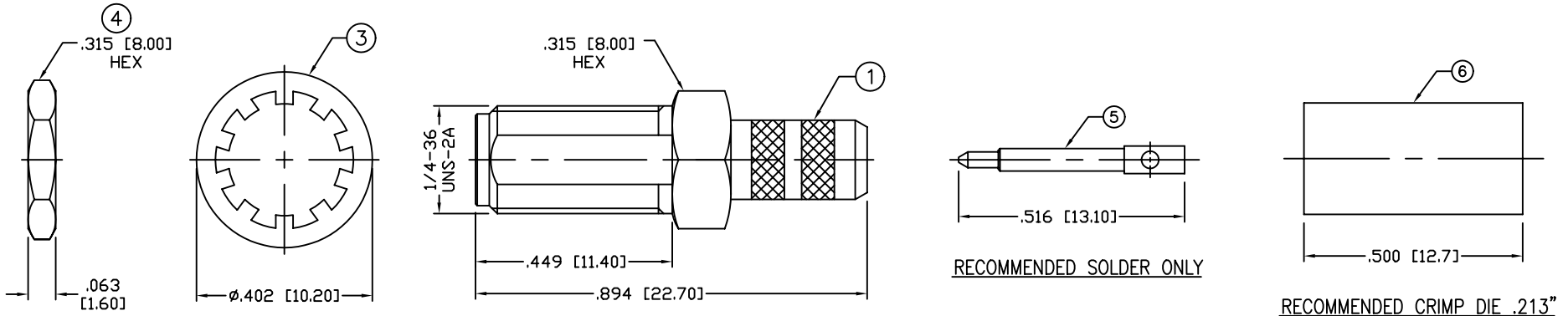

SPECIFICATIONS:

IMPEDANCE: 50 Ohms
 FREQUENCY RANGE: 0-12.4 GHz
 INSERTION LOSS(dB): $0.03 \times \sqrt{f(\text{GHz})}$
 VSWR: 1.3 MAX.
 WORKING VOLTAGE: 500 V rms Max. @ Sea Level
 INSULATION RESISTANCE: 5k M Ohms min.
 TEMPERATURE RANGE: -65°C TO 165°C
 FOR RG-58, 58A, 58C, 141, 141A, BELDEN 8240,
 8259, 8262, 9201, 9203, 9310, 9311 & COMM/SCOPE 0268

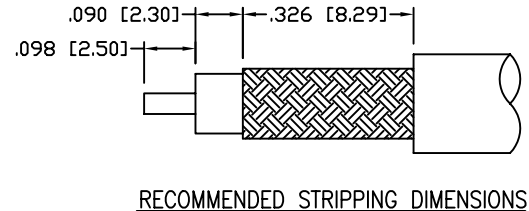
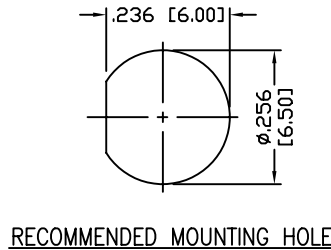

1	BODY	1	BRASS	GOLD, 3 μ"	008974	
2	INSULATOR	1	PTFE	---		
3	LOCK WASHER	1	BRASS	GOLD, 3 μ"		
4	HEX NUT	1	BRASS	GOLD, 3 μ"		
5	PIN	1	BRASS	GOLD, 50 μ"		
6	FERRULE	1	BRASS	GOLD, 3 μ"		
7						
8						
9						
10					DRAWN	
11					C. ZUNIGA	
12					CHECKED	
13					6/27/05	
14						
					ORJ DRAWN	
					C. ZUNIGA	
					8/21/02	
#	DESCRIPTION	QTY	MATERIAL	FINISH	APPROVALS	DATE

UNLESS OTHERWISE SPECIFIED:
 1. REMOVE ALL BURRS
 2. BREAK ALL CORNERS & EDGES .005 R. MAX.
 3. CHAMFER 1ST & LAST THREADS 45°
 4. SURFACE ROUGHNESS 63 FINISH MIL-STD-10
 5. DIAMETERS ON COMMON CENTERS TO BE CONCENTRIC WITHIN .002 T.I.R.
 6. ALL DIMENSIONS ARE AFTER PLATING.

DIMENSIONS ARE IN INCHES AND [MILLIMETERS]
 UNLESS OTHERWISE NOTED TOLERANCES ARE:

DECIMALS	DIAMETER
.xxx±.003 [.08]	.xxx±.001 [.03]
.xx±.005 [.13]	.xx±.003 [.08]

7610 MIRAMAR RD
 SAN DIEGO, CA 92126
 (858) 549-6340
 (858) 549-6345 FAX

RF connectors
 DIVISION OF RF INDUSTRIES, LTD.

SMA JACK, CRIMP

REVERSE POLARITY, BULKHEAD

SIZE	CABLE GROUP	DWG NO.	REV
A	C	RP-3252-1C	A

SCALE: NTS CAD FILE OUTLINE SHEET 1 OF 1