



## MAX8845Z Evaluation Kit

### General Description

The MAX8845Z evaluation kit (EV kit) is a fully assembled and tested PCB for evaluating the MAX8845Z/MAX8845Y 28V linear Li+ battery chargers.

The MAX8845Z EV kit features an overvoltage-protected LDO output (SAFEOUT) for low-voltage-rated USB or charger inputs in the system, and a battery pack detection circuit (DETBAT) that disables the IC when the battery pack is absent. The IC disables charging if the input sources exceed 7.5V to protect against unqualified or faulty AC adapters. The MAX8845Z EV kit also features an adjustable fast-charge current set by an external resistor (R1) and an adjustable top-off current threshold set by an external resistor (R2).

Other features include an active-low control input ( $\overline{\text{EN}}$ ) and an active-low input power source detection output ( $\overline{\text{POK}}$ ). The IC also contains a booting assistant circuit that distinguishes input sources and battery connection, and provides an output signal (MAX8845Z = ABO, MAX8845Y = ABO) for system booting.

To evaluate the MAX8845Y version, order the MAX8845YETC+ along with the MAX8845ZEVKIT+ and see the *Evaluating the MAX8845Y* section.

### Features

- ◆ CCCV, Thermally Regulated Linear Single-Cell Li+ Battery Charger
- ◆ No External MOSFET, Reverse-Blocking Diode, or Current-Sense Resistor
- ◆ Programmable Fast-Charge Currents (1A<sub>RMS</sub> max)
- ◆ Programmable Top-Off Current Threshold
- ◆ Input Overvoltage-Protected 4.7V Output (SAFEOUT) from DC
- ◆ Proprietary Die Temperature Regulation Control (+115°C)
- ◆ 4.25V to 28V Input-Voltage Range with Input Overvoltage Protection Above +7.5V
- ◆ Low-Dropout Voltage (300mV at 500mA)
- ◆ Input Power-Source Detection Output ( $\overline{\text{POK}}$ ), Charge Status Output ( $\overline{\text{CHG}}$ ), and Charge-Enable Input ( $\overline{\text{EN}}$ )
- ◆ Output for Autobooting (MAX8845Z = ABO, MAX8845Y = ABO)
- ◆ Lead(Pb)-Free and RoHS Compliant

### Ordering Information

PART	TYPE
MAX8845ZEVKIT+	EV Kit

+Denotes lead(Pb)-free and RoHS compliant.

### Component List

DESIGNATION	QTY	DESCRIPTION
C1	1	1 $\mu$ F $\pm$ 10%, 35V X5R ceramic capacitor (0603) Taiyo Yuden GMK107BJ105KA
C2	1	2.2 $\mu$ F $\pm$ 10%, 10V X5R ceramic capacitor (0603) Taiyo Yuden LMK107BJ225KA Murata GRM188R61A225KE34
C3	1	0.1 $\mu$ F $\pm$ 10%, 16V X7R ceramic capacitor (0402) TDK C1005X7R1C683K

DESIGNATION	QTY	DESCRIPTION
C4	1	1 $\mu$ F $\pm$ 10%, 10V X5R ceramic capacitor (0402) Murata GRM155R61A105K
C5	0	Not installed, capacitor
D1, D2	2	Red LEDs Panasonic LNJ208R8ARA
JU1–JU4	4	2-pin headers, 0.1in center Sullins PEC36SAAN Digi-Key S1012E-36-ND
R1	1	2.80k $\Omega$ $\pm$ 1% resistor (0402)



# MAX8845Z Evaluation Kit

## Component List (continued)

DESIGNATION	QTY	DESCRIPTION
R2	1	1.74k $\Omega$ $\pm$ 1% resistor (0402)
R3, R4	2	200 $\Omega$ $\pm$ 5% resistors (0402)
R5	1	4.7k $\Omega$ $\pm$ 5% resistor (0402)
R6, R7	0	Not installed, resistors—PCB short (0402)
R8	1	200k $\Omega$ $\pm$ 5% resistor (0402)

DESIGNATION	QTY	DESCRIPTION
U1	1	28V linear Li+ battery charger (12 Thin QFN-EP*) Maxim MAX8845ZETC+ (Top Mark: ABL)
—	1	PCB: MAX8845Z Evaluation Kit+

\*EP = Exposed pad.

## Component Suppliers

SUPPLIER	PHONE	WEBSITE
Digi-Key Corp.	800-344-4539	www.digikey.com
Murata Electronics North America, Inc.	770-436-1300	www.murata-northamerica.com
Panasonic Corp.	800-344-2112	www.panasonic.com
Sullins Electronics Corp.	760-744-0125	www.sullinselectronics.com
Taiyo Yuden	800-348-2496	www.t-yuden.com
TDK Corp.	847-803-6100	www.component.tdk.com

**Note:** Indicate that you are using the MAX8845Z when contacting these component suppliers.

## Quick Start

### Recommended Equipment

- 4V to 28V adjustable power supply (PS1) capable of 1A
- One 5V power supply (PS2) capable of 100mA
- Three digital multimeters (DMM1, DMM2, DMM3)
- One 10A ammeter
- One single-cell lithium-ion (Li+) battery (not fully charged)

### Procedure

The MAX8845Z EV kit is a fully assembled and tested surface-mount board. Follow the steps below and Figure 1 to set up and verify the MAX8845Z and board operation:

- 1) Preset the power supply (PS1) to 5V. Turn off the power supply. **Do not turn on the power supply until all connections are completed.**
- 2) Preset the power supply (PS2) to 5V. Turn off the power supply. **Do not turn on the power supply until all connections are completed.**
- 3) Verify that a shunt is installed on JU1 ( $\overline{EN}$ ) to set the EV kit in disable mode.
- 4) Verify that a shunt is installed on JU2 (DETBAT).
- 5) Verify that JU3 and JU4 are open and shunts are not installed.
- 6) Connect the positive lead of the power supply (PS1) to the EV kit pad labeled IN. Connect the negative lead of the power supply to the EV kit pad labeled GND.
- 7) Connect the positive lead of the power supply (PS2) to the EV kit pad labeled VI/O. Connect the negative lead of the power supply to the EV kit pad labeled GND.
- 8) Observe correct Li+ cell polarity. Connect the single-cell Li+ battery and 10A ammeter, as shown in Figure 1. The positive lead of the ammeter must connect to BATT+ and the negative lead to the positive terminal of the Li+ battery.
- 9) Connect a digital multimeter (DMM1) across the Li+ battery. Connect the positive lead of DMM1 to the positive terminal of the Li+ battery. Connect the negative lead of DMM1 to the negative terminal of the Li+ battery and note the battery voltage. If  $V_{BATT} < 2.5V$ , the charger starts in precharge mode. If  $V_{BATT} \geq 2.5V$ , the charger starts up in fast-charge mode.

# MAX8845Z Evaluation Kit

- 10) Connect a digital multimeter (DMM2) from ABO (MAX8845Z only) to GND.
- 11) Connect a digital multimeter (DMM3) from SAFEOUT to GND.
- 12) Turn on PS1 and then turn on PS2.
- 13) Remove the shunt on JU1 to set the EV kit in enable mode.
- 14) Verify that D2 is emitting light, indicating that  $\overline{POK}$  is low and input power is valid.
- 15) Verify that the voltage read by DMM3 is approximately 4.7V.
- 16) If the charger is in fast-charge mode, verify that the ammeter reads approximately 500mA. If the charger is in precharge mode, verify that the ammeter reads approximately 50mA.
- 17) Verify that D1 is emitting light, indicating that  $\overline{CHG}$  is low and the battery charger is on.  
**Note:** If the battery is fully charged, D1 will not emit light.
- 18) Verify that the voltage read by DMM2 is approximately the same voltage read by DMM1.
- 19) When the battery is fully charged, DMM1 reads 4.2V.
- 20) Remove the shunt on JU2 and verify that D1 and D2 are not emitting light.
- 21) Install a shunt on JU2.
- 22) Turn off the input power supply (PS1).
- 23) Verify that D2 is not emitting light and the voltage read by DMM2 is 0V.
- 24) Install a shunt on JU4.
- 25) Verify that the voltage read at DMM2 is approximately the same voltage read by DMM1.
- 26) Turn on PS1 and increase to 8V.
- 27) Verify that D1 and D2 are not emitting light and the voltage read by DMM3 is 0V.

When evaluation of the MAX8845Z EV kit is completed, use the following steps to power down the EV kit:

- 1) Install a shunt on JU1.
- 2) Turn off both power supplies.
- 3) Remove the battery.
- 4) Disconnect all test leads from the EV kit.

## Detailed Description of Hardware

The MAX8845Z/MAX8845Y chargers use voltage, current, and thermal-control loops to charge a single Li+ cell and protect the battery. When a Li+ battery with a cell voltage below 2.5V is inserted, the MAX8845Z/MAX8845Y chargers enter a prequalification stage where it precharges that cell with 10% of the user-programmed fast-charge current. The  $\overline{CHG}$  indicator is driven low to indicate entry into the prequalification state. When the battery voltage exceeds 2.5V, the IC soft-starts as it enters the fast-charge stage. The fast-charge current level is programmed through a resistor from SET1 to GND. As the battery voltage approaches 4.2V, the battery current is reduced. If the battery current drops to less than the top-off current threshold set by RMIN, the IC enters top-off mode and the  $\overline{CHG}$  indicator goes high impedance, signaling that the battery is fully charged.

### **Overvoltage-Protected Output (SAFEOUT)**

SAFEOUT is a linear regulator that provides an output voltage of 4.7V and can be used to supply low-voltage-rated charging systems. The SAFEOUT linear regulator turns on when  $V_{IN} \geq 4.25V$  regardless of  $\overline{EN}$  and is disabled when  $V_{IN}$  is greater than the overvoltage threshold (7.5V typ).

### **Battery Pack Detection Input (DETBAT)**

DETBAT is a battery pack ID resistor detector that enables the battery charger if pulled low through a resistor that is  $< 51k\Omega$ . By installing a header on JU2, DETBAT is pulled to ground through R5 (4.7k $\Omega$ ). If DETBAT is left unconnected, or the pulldown resistor is 51k $\Omega$  or greater, the battery charger is disabled. If DETBAT is not used, connect DETBAT to GND for normal operation.

### **$\overline{POK}$ Output**

The open-drain  $\overline{POK}$  output asserts low when  $2.35V \leq V_{IN} \leq 7V$ ,  $(V_{IN} - V_{BATT}) \geq 40mV$  (typ  $V_{IN}$  rising), and  $\overline{DETBAT}$  is pulled low through a resistor that is  $< 51k\Omega$ .  $\overline{POK}$  is high impedance during shutdown. When interfacing with a microprocessor logic input, a pullup resistor to the microprocessor's I/O voltage may be required.

### **Autobooting Assistant**

The MAX8845Z/MAX8845Y contain an autobooting assistant circuit that generates an enable signal for system booting (MAX8845Z = ABO, MAX8845Y =  $\overline{ABO}$ ). For the MAX8845Z, the booting assistant functions as an internal OR gate (refer to the MAX8845Z/MAX8845Y IC data sheet). The first input is dependent on the input supply voltage  $V_{IN}$  and DETBAT, while the second input

# MAX8845Z Evaluation Kit

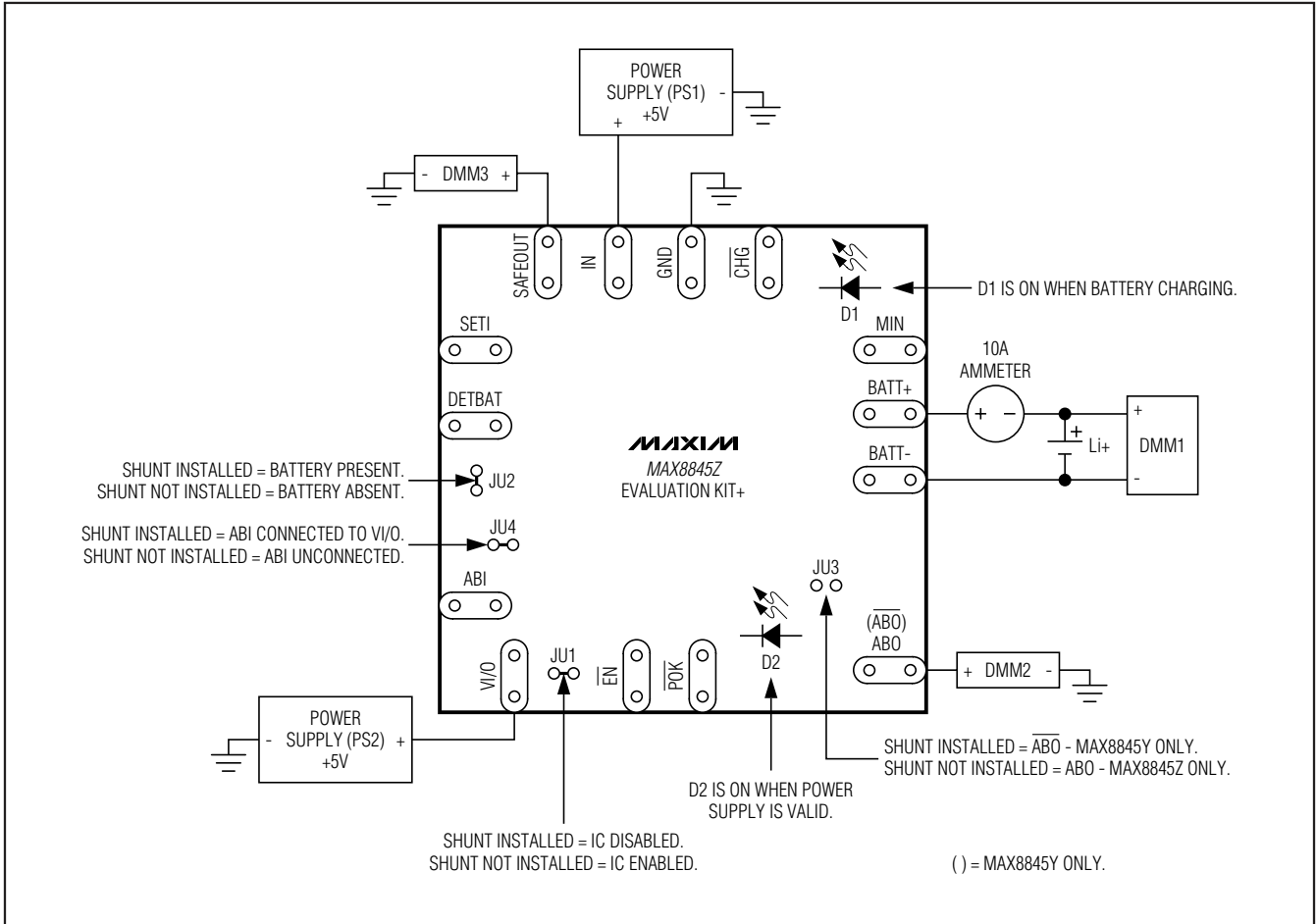

Figure 1. Test Procedure Setup for MAX8845Z EV Kit

Table 1. Jumper Settings (JU1–JU4)

JUMPER	DEFAULT SETTINGS	FUNCTION
JU1	Installed	JU1 connects $\overline{EN}$ (active-low enable input) to VI/O (system supply). Install a shunt on JU1 to disable the IC. $\overline{EN}$ has an internal pulldown resistor to GND. Remove the shunt from JU1 to enable the IC.
JU2	Installed	JU2 connects DETBAT (battery pack ID resistor detection input) to GND through R5. Install a shunt on JU2 to simulate battery present. Remove the shunt on JU2 to simulate battery absent.
JU3	Not installed	Remove the shunt on JU3 to evaluate the MAX8845Z with an active-high autoboosting logic output (ABO). Install a shunt on JU3 to connect $\overline{ABO}$ to the VI/O supply through R8 in order to achieve a logic-high output on the drain of the internal open-drain MOSFET (MAX8845Y only).
JU4	Not installed	JU4 connects ABI (autoboosting input) to VI/O (system supply). Install a shunt on JU4 to connect ABI to VI/O. Remove the shunt on JU4 to leave ABI unconnected and when ABI is driven by an external source.

# MAX8845Z Evaluation Kit

Evaluates: MAX8845Z/MAX8845Y

is an external signal applied to ABI. The first input ( $\overline{POK}$ ) is driven high once DETBAT is pulled low through a resistor  $< 51k\Omega$ ,  $2.35V \leq V_{IN} \leq 7V$ , and  $(V_{IN} - V_{BATT}) \geq 40mV$  (typ  $V_{IN}$  rising).

The second input signal (ABI) is driven by an external source (see Table 2). ABI enables an autoboot signal when a battery is connected at BATT and is independent of POK. If POK is pulled low, the booting assistant always drives ABO high (MAX8845Z), regardless of ABI. ABI is pulled to GND through an internal  $200k\Omega$  resistor. If ABI is supplied from an outside exposed pin, an RC filter (R1/C3 in Figure 2) is required for ESD protection and noise filtering. If ABI is supplied by a system's internal GPIO, or logic, the RC filter is not required.

For the MAX8845Y, the output  $\overline{ABO}$  is only dependent on the state of ABI (Table 2).

## Charger Enable Input

The MAX8845Z EV kit contains an active-low logic input ( $\overline{EN}$ ) used to enable the IC. Drive  $\overline{EN}$  low, leave JU1 unconnected, or connect  $\overline{EN}$  to GND to enable the charge-control circuitry. Drive  $\overline{EN}$  high to disable the charge-control circuitry.  $\overline{EN}$  has an internal  $200k\Omega$  pull-down resistor.

## Fast-Charge Current Setting

The maximum charging current is programmed by an external resistor connected from SET1 to GND (R1 in Figure 2). Use the following equation to determine the fast-charge current ( $I_{FAST\_CHARGE}$ ):

$$I_{FAST\_CHARGE} = \frac{1400V}{R_{SET1}}$$

where  $I_{FAST\_CHARGE}$  is in amperes and  $R_{SET1}$  is in ohms.  $R_{SET1}$  must always be  $1.40k\Omega$  or higher due to the continuous charging current limit of 1A. The voltage at SET1 can be used to monitor the fast-charge current level. The output current from SET1 is  $1016\mu A$  per

ampere of charging current. The output voltage at SET1 is proportional to the charging current:

$$V_{SET1} = \frac{I_{CHARGE} \times R_{SET1}}{1016}$$

The voltage at SET1 is nominally 1.4V at the selected fast-charge current, and falls with charging current as the cell becomes fully charged or as the thermal-regulation circuitry activates.

## Top-Off Current Threshold Setting

The top-off current threshold is programmed by an external resistor connected from MIN to GND (R2 in Figure 2). Use the following equation to determine the top-off current ( $I_{MIN}$ ):

$$I_{MIN} = \frac{140V}{R_{MIN}}$$

where  $I_{MIN}$  is in amperes and  $R_{MIN}$  is in ohms.

## Thermal Regulation

The thermal-regulation loop limits the MAX8845Z/MAX8845Y die temperature to  $+115^{\circ}C$  by reducing the charge current, as necessary. This feature not only protects the IC from overheating, but also allows a higher charge current without risking damage to the IC.

## Evaluating the MAX8845Y

To evaluate the MAX8845Y version, order the MAX8845YETC+ along with the MAX8845ZEVKIT+. Remove U1 and replace with the MAX8845YETC+ (Top Mark: ABM) and install a shunt on JU3. The MAX8845Y features an active-low autobooting logic output ( $\overline{ABO}$ ) and requires an external power supply (VI/O on the MAX8845Z EV kit) to achieve logic-high.

To evaluate the MAX8845Y and board operation, see Figures 1 and 3 and follow the procedure on the next page. The MAX8845Y procedure is similar to the MAX8845Z procedure with a few minor differences.

**Table 2. Autobooting Output States**

ABI	BATT	$\overline{POK}$	CHARGER STATE	ABO (MAX8845Z)	$\overline{ABO}$ (MAX8845Y)
Low	Present	High impedance	Shutdown	Low	High impedance
High	Present	High impedance	Shutdown	High	Low
Low	Not present	Low	Fast charge/top off	High	High impedance
Low	Present	Low	Fast charge/top off	High	High impedance
High	Present	Low	Fast charge/top off	High	Low

**Note:** Present indicates that  $V_{BATT} \geq 2V$  and not present indicates that battery is not connected.

## MAX8845Z Evaluation Kit

### MAX8845Y Procedure

Follow the steps below and Figure 1 to set up and verify the MAX8845Y and board operation:

- 1) Preset the power supply (PS1) to 5V. Turn off the power supply. **Do not turn on the power supply until all connections are completed.**
- 2) Preset the power supply (PS2) to 5V. Turn off the power supply. **Do not turn on the power supply until all connections are completed.**
- 3) Verify that a shunt is installed on JU1 ( $\overline{\text{EN}}$ ) to set the EV kit in disable mode.
- 4) Verify that a shunt is installed on JU2 (DETBAT).
- 5) Verify that a shunt is installed on JU3. Verify that a shunt is installed on JU4.
- 6) Connect the positive lead of the power supply (PS1) to the EV kit pad labeled IN. Connect the negative lead of the power supply to the EV kit pad labeled GND.
- 7) Connect the positive lead of the power supply (PS2) to the EV kit pad labeled VI/O. Connect the negative lead of the power supply to the EV kit pad labeled GND.
- 8) Observe correct Li+ cell polarity. Connect a single-cell Li+ battery and 10A ammeter, as shown in Figure 1. The positive lead of the ammeter must connect to BATT+ and the negative lead to the positive terminal of the Li+ battery.
- 9) Connect a digital multimeter (DMM1) across the Li+ battery. Connect the positive lead of DMM1 to the positive lead of the Li+ battery. Connect the negative lead of DMM1 to the negative terminal of the Li+ battery and note the battery voltage. If  $V_{\text{BATT}} < 2.5\text{V}$ , the charger starts in precharge mode. If  $V_{\text{BATT}} \geq 2.5\text{V}$  the charger starts up in fast-charge mode.
- 10) Connect a digital multimeter (DMM2) from  $\overline{\text{ABO}}$  to GND.
- 11) Connect a digital multimeter (DMM3) from SAFEOUT to GND.
- 12) Turn on PS1 and then turn on PS2.
- 13) Remove the shunt on JU1 to set the EV kit in enable mode.
- 14) Verify that D2 is on indicating  $\overline{\text{POK}}$  is low and input power is valid.
- 15) Verify that the voltage read by DMM3 is approximately 4.7V.
- 16) If the charger is in fast-charge mode, verify that the ammeter reads approximately 500mA. If the charger is in precharge mode, verify that the ammeter reads approximately 50mA.
- 17) Verify that D1 is on indicating that  $\overline{\text{CHG}}$  is low and the battery charger is on.
 

**Note:** If the battery is fully charged, D1 will not turn on.
- 18) Verify that the voltage read by DMM2 is 0V.
- 19) When the battery is fully charged, DMM1 reads 4.2V.
- 20) Remove the shunt on JU2 and verify that D1 and D2 are not emitting light.
- 21) Install a shunt on JU2.
- 22) Turn off the input power supply (PS1).
- 23) Verify that D2 is not emitting light and that the voltage read by DMM2 is approximately 5V.
- 24) Remove the shunt on JU4.
- 25) Verify that the voltage read by DMM2 is approximately 5V.
- 26) Turn on PS1 and increase to 8V.
- 27) Verify that D1 and D2 are not emitting light and that the voltage read by DMM3 is 0V.

When evaluation of the MAX8845Y is completed, use the following steps to power down the EV kit:

- 1) Ensure a shunt on JU1.
- 2) Turn off both power supplies.
- 3) Remove the battery.
- 4) Disconnect all test leads from the EV kit.

# MAX8845Z Evaluation Kit

Evaluates: MAX8845Z/MAX8845Y

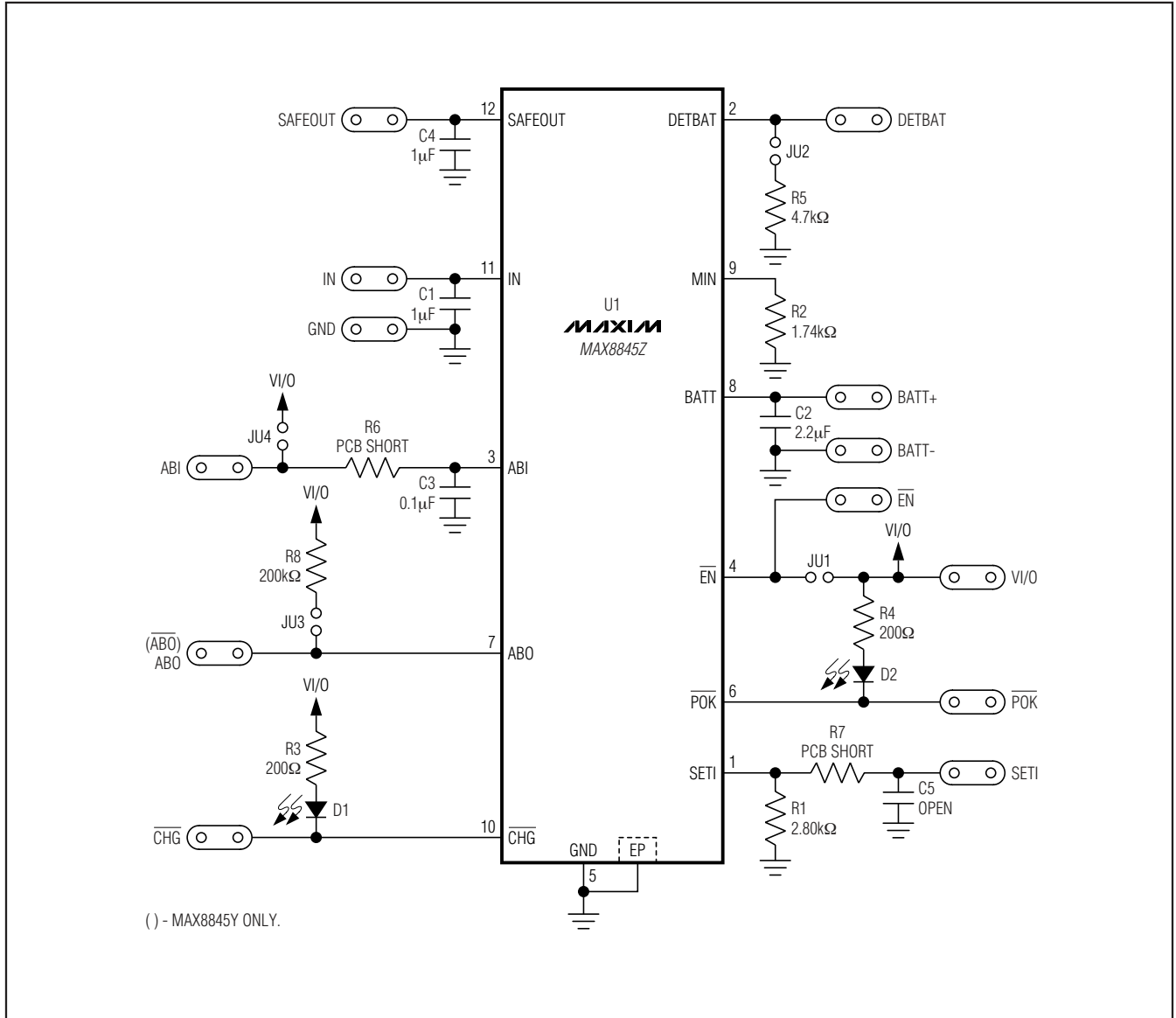

Figure 2. MAX8845Z EV Kit Schematic

# MAX8845Z Evaluation Kit

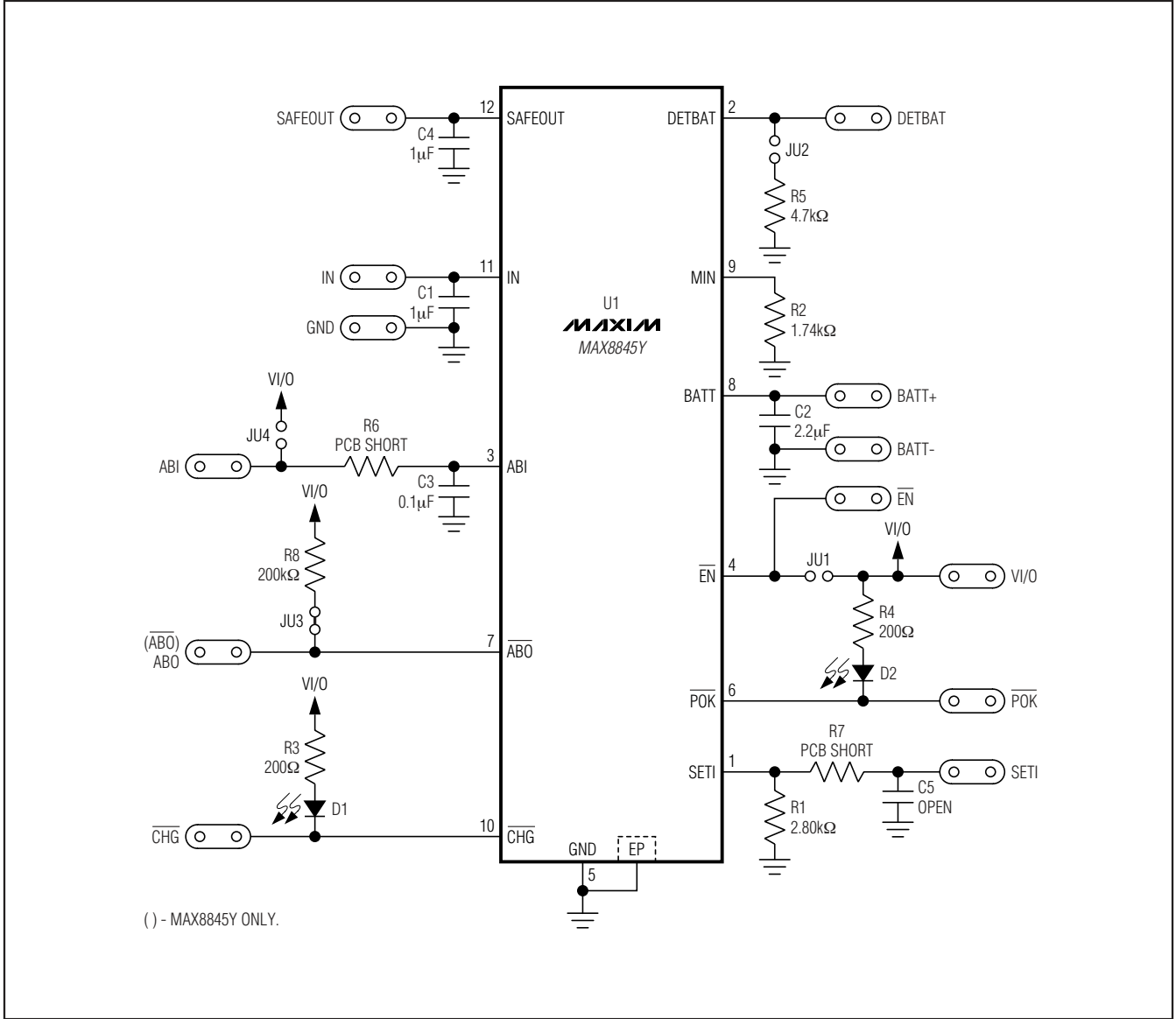

Figure 3. MAX8845Y EV Kit Schematic



# MAX8845Z Evaluation Kit

Evaluates: MAX8845Z/MAX8845Y

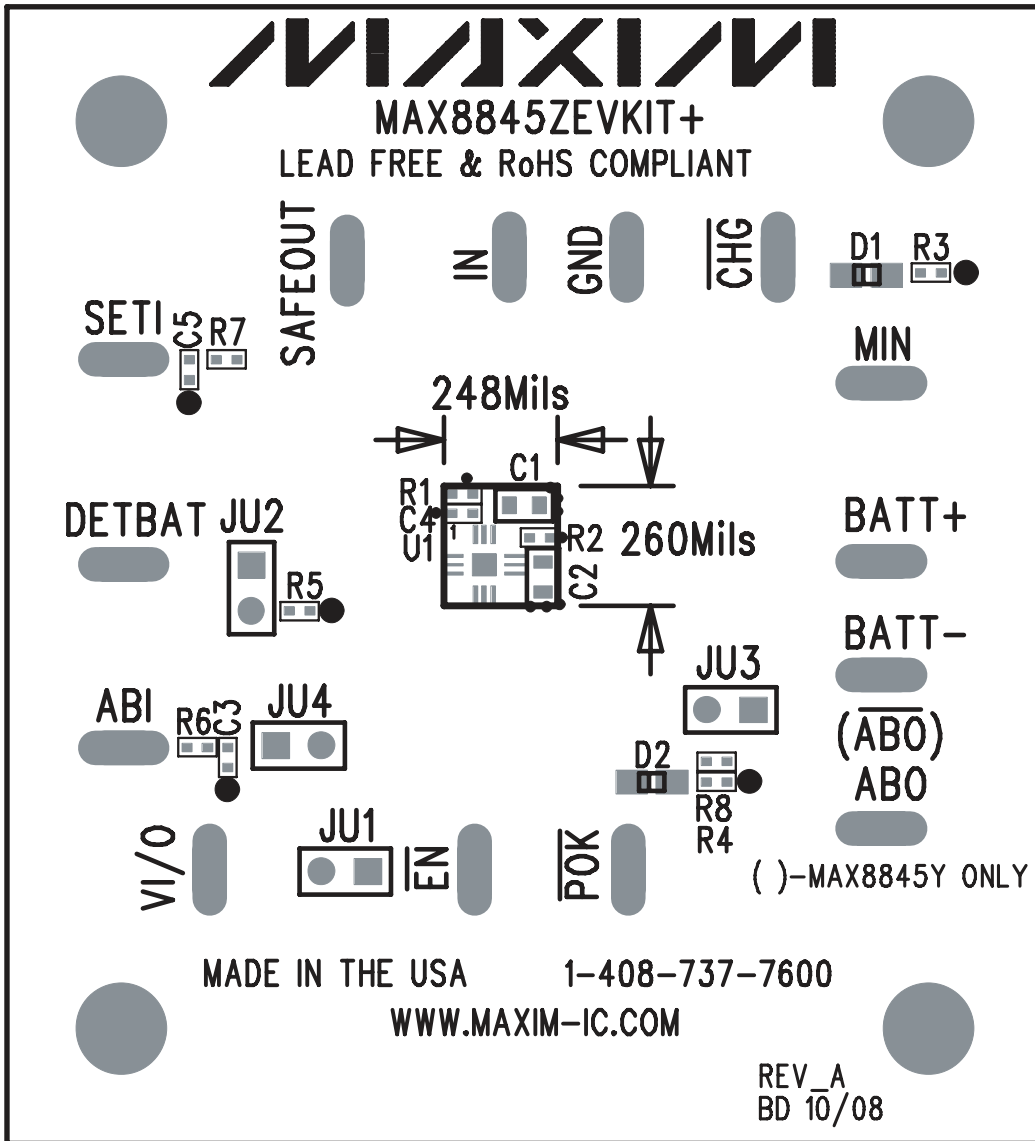

Figure 4. MAX8845Z EV Kit Component Placement Guide—Component Side

# MAX8845Z Evaluation Kit

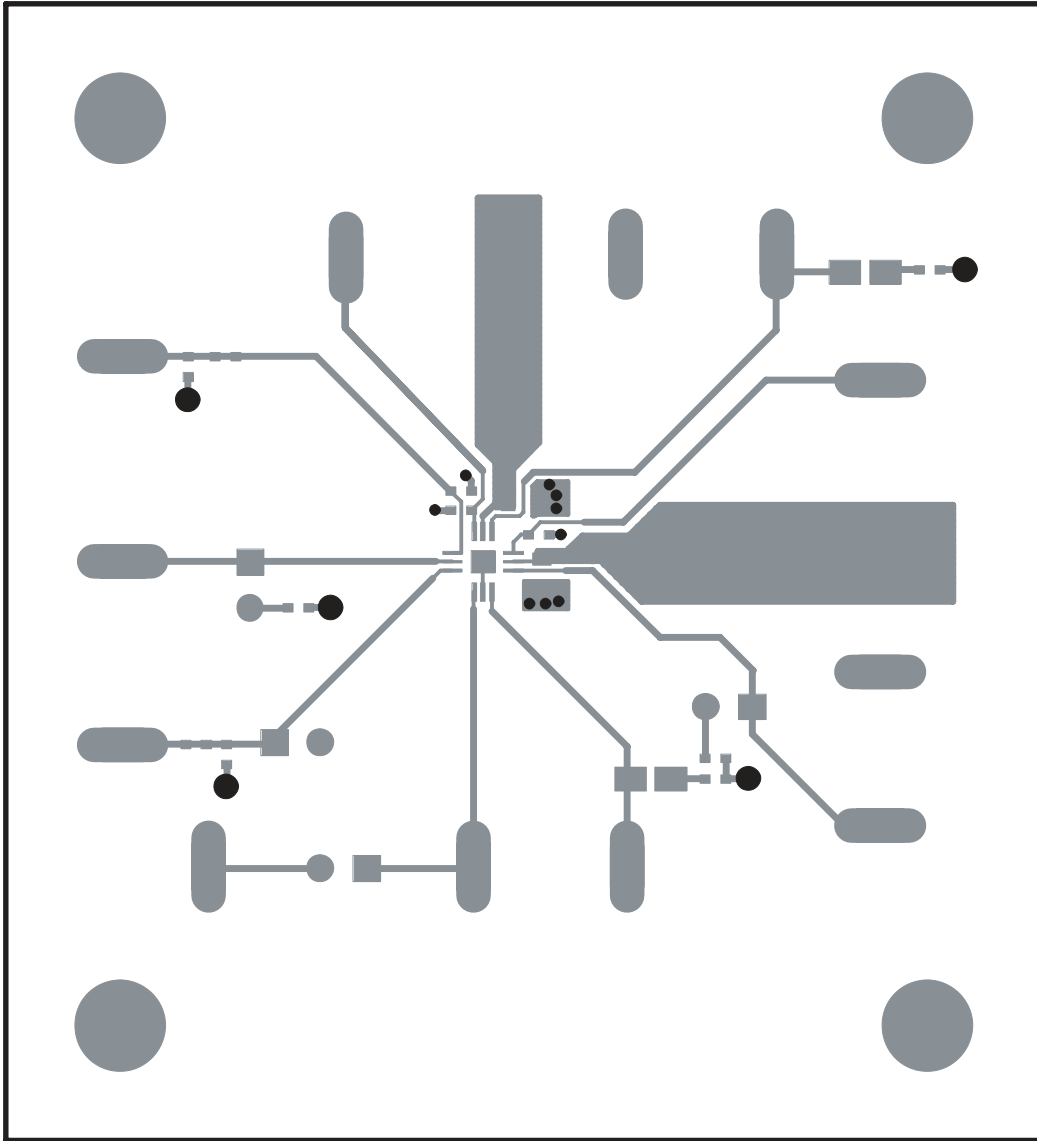

Figure 5. MAX8845Z EV Kit PCB Layout—Component Side

# MAX8845Z Evaluation Kit

Evaluates: MAX8845Z/MAX8845Y

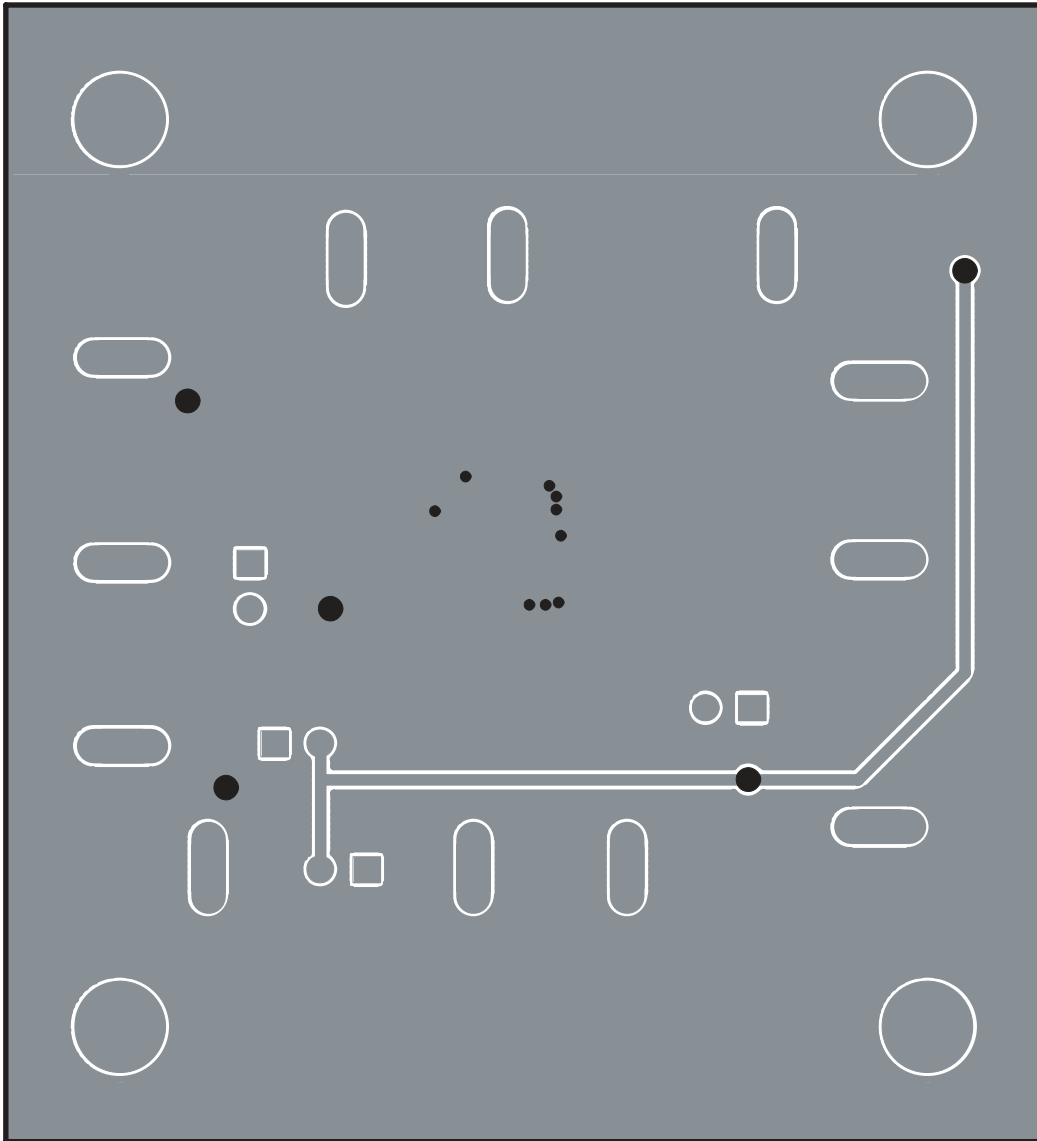

Figure 6. MAX8845Z EV Kit PCB Layout—Solder Side

Maxim cannot assume responsibility for use of any circuitry other than circuitry entirely embodied in a Maxim product. No circuit patent licenses are implied. Maxim reserves the right to change the circuitry and specifications without notice at any time.

Maxim Integrated Products, 120 San Gabriel Drive, Sunnyvale, CA 94086 408-737-7600 \_\_\_\_\_ 11