

LEGEND  = KEY PRODUCT CHARACTERISTICS

REVISION HISTORY

REV	DESCRIPTION	DATE	BY	ECN
0	FIRST ISSUE	10/12/2010	M.H	8983

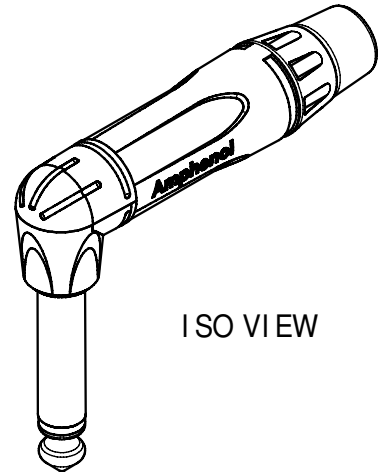
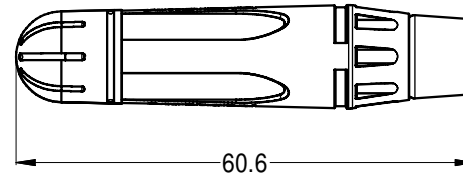

ISO VIEW

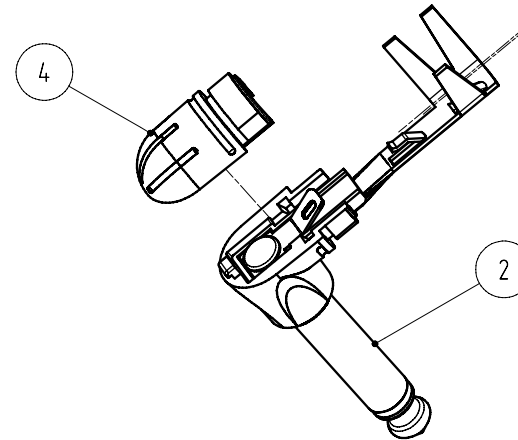
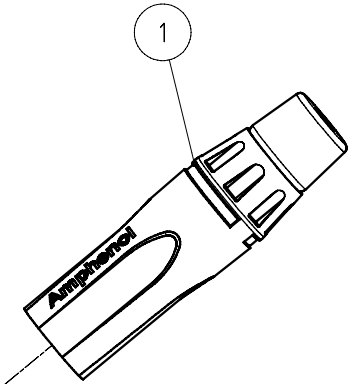
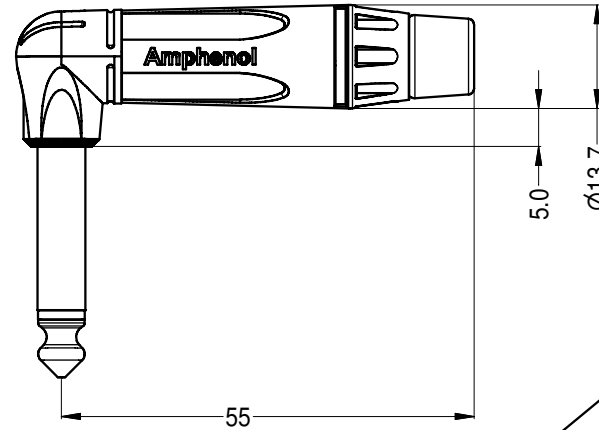
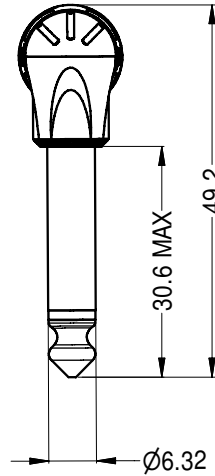

EXPLORED VIEW

NOTE: SUITABLE FOR 8mm OD CABLE

ITEM	PART NUMBER	DESCRIPTION	QTY
4	50300105-x21	RA DIECAST CAP NICKEL/BLACK FINISH	1
3	51270031-521	RA INSULATE PVC TUBE CLEAR	1
2	50310043-x30	RA MONO INSERT ASSEMBLY NICKEL/GOLD	1
1	53490006-331/431	DIECAST SHELL NICKEL/BLACK FINISH	1

Parts List

PART NUMBER		
PART NUMBER	SHELL FINISH	CONTACT FINISH
ACPM-TN	NICKEL	NICKEL RING, SLEEVE & TIP
ACPM-TN-AU	NICKEL	GOLD RING, SLEEVE & TIP
ACPM-TB	BLACK	NICKEL RING, SLEEVE & TIP
ACPM-TB-AU	BLACK	GOLD RING, SLEEVE & TIP

UNLESS OTHERWISE SPECIFIED TOLERANCE TO BE		THIS DOCUMENT IS THE PROPERTY OF AMPHENOL AUSTRALIA PTY. LTD. NO PART THEREOF MAY BE REPRODUCED AND USED WITHOUT THE PRIOR WRITTEN CONSENT OF THE OWNER			
LINER	ANGULAR	MATERIAL:	DRN: T.Z	DATE: 10-12-10	TITLE: 1/4" MONO PHONE RA PLUG M-SERIES II CUSTOMER DRAWING
X ± 0.5	X' ± 1	SEE PARTS LIST & TABLE	CKD: M.H	DATE: 10-12-10	
X.X ± 0.25	X.X' ± 30'	FINISH: SEE TABLE	APP'D: P.M	DATE: 10-12-10	
X.XX ± 0.1	X.XX' ± 15'	DIMENSIONS IN MILLIMETRES	SCALE: 2:1	SIZE: A4	PART No: SEE TABLE
BREAK ALL SHARP EDGES AND REMOVE ALL BURRS		THIRD ANGLE PROJECTION	DRAWING NO. 55010752-000-1		

Amphenol Amphenol Australia Pty. Ltd.
2 Fiveways Blvd, Keysborough, VIC 3173