

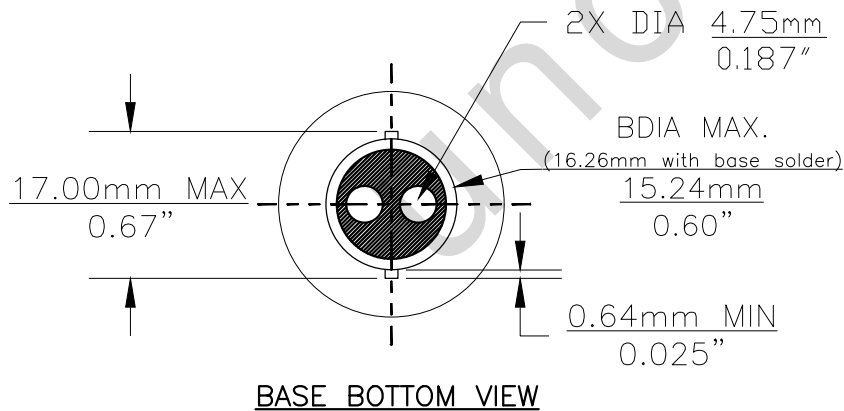

Since 1959

PART NO.	BASE TYPE	DESIGN VOLTS	DESIGN AMPS	MSCD	FILAMENT TYPE	AVERAGE LIFE HOURS	REVISIONS			
							REV #	DESCRIPTION	DATE	APPROVED
2057LL	D.C. INDEX BAY15d	12.8V 14V	2.1±5% 0.48±8%	32±10% 2±12%	C-6 C-6	2000 10,000	1	ISSUED	01/04/2001	A.S.
							2	REDRAWN	05/14/2007	D.C.

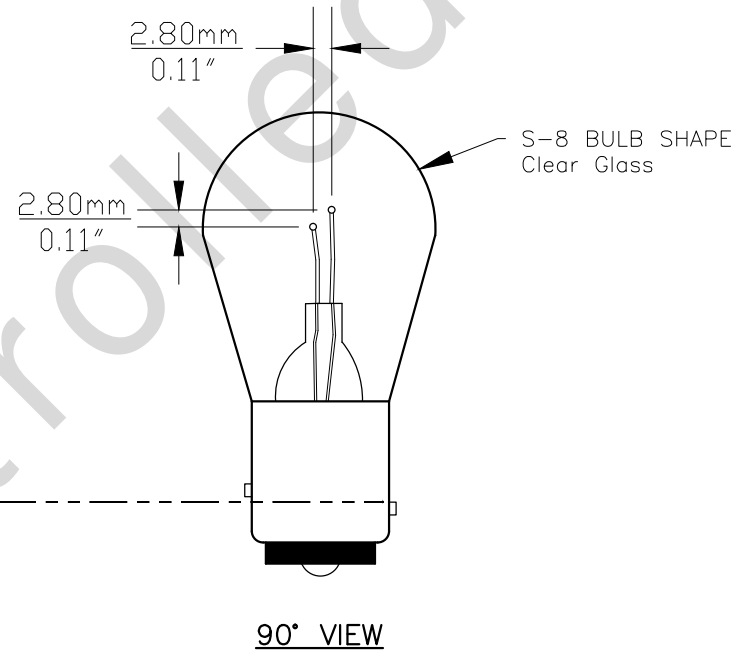
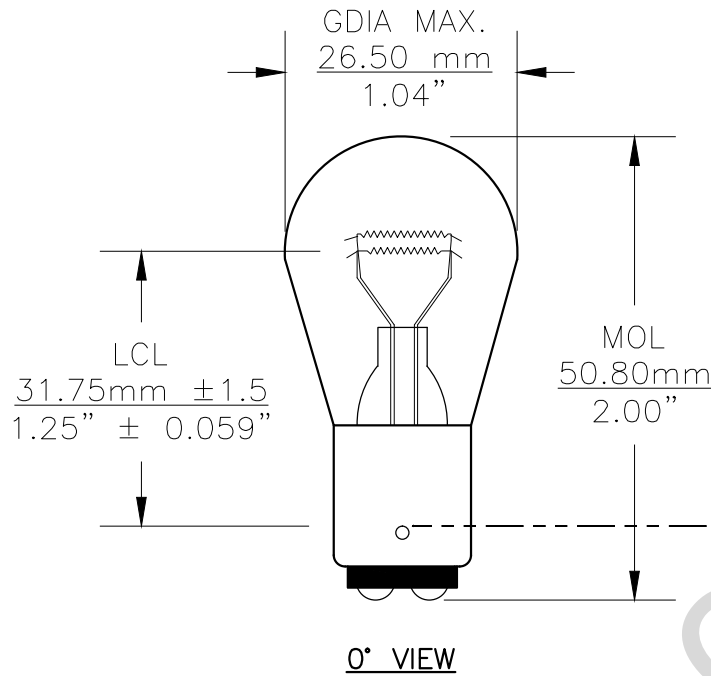

Note: Made according to SAE specifications

UNLESS OTHERWISE SPECIFIED: DIMENSIONS ARE IN INCHES TOLERANCES		CEC INDUSTRIES LTD			
DECIMALS	ANGULAR	599 BOND STREET		LINCOLNSHIRE, IL 60069	
.XX ± .05	± 0.5°	TITLE LIGHT BULB NO. 2057LL			
.XXX ± .010		SCALE	PLOT SCALE	SHEET 1 OF 1	REV 2
FRACTIONAL	±1/64	FILE 2057LL.pdf		DRAWING NOT TO SCALE	