

REVISIONS			
LTR	DESCRIPTION	DATE	APPROVED
C	REVISED DWG PER DCR No. C070005	1/10/07	GMR

DETAIL A
 OPTION 1
 (SCALE: NONE)
 SEE SHEET 3, 2.3

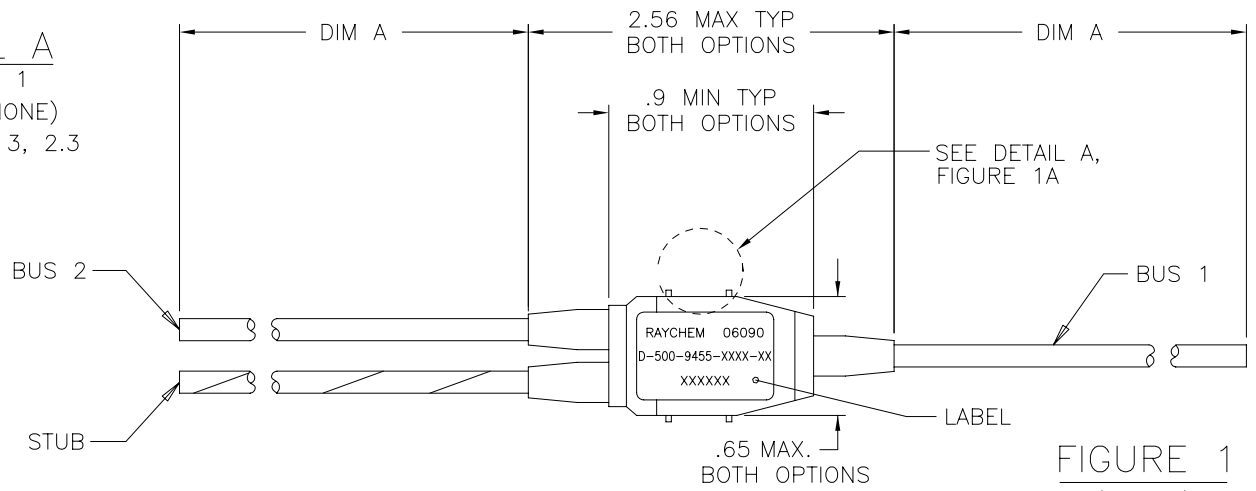
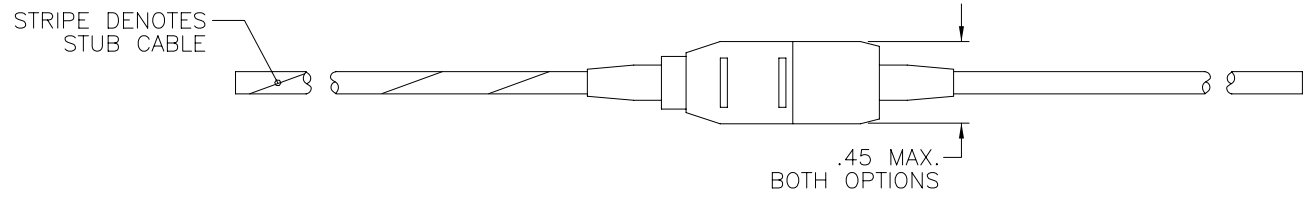

FIGURE 1
 (SINGLE)
 D-500-9455-XXXX-XX



SINGLE STUB COUPLER SCHEMATIC
 (BOTH FIGURE 1 AND FIGURE 1A)

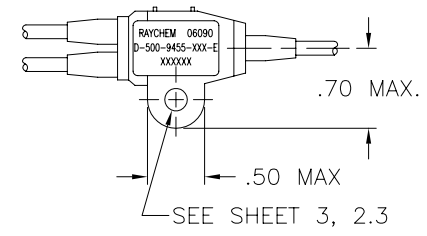
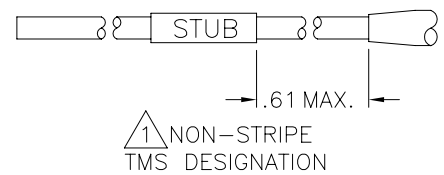
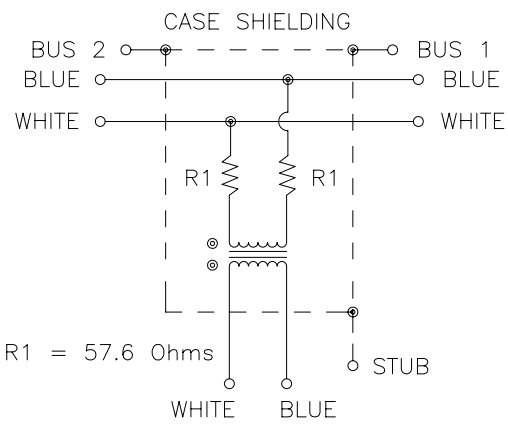
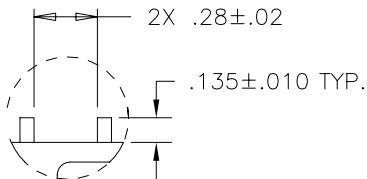

FIGURE 1A
 OPTION 2
 (SCALE: NONE)
 D-500-9455-XXX-E

If this document is printed it becomes uncontrolled. Check for the latest revision

SPECIFICATION CONTROL DRAWING
 © 2007 Tyco Electronics Corporation. All Rights Reserved.

UNLESS OTHERWISE SPECIFIED DIMENSIONS ARE IN INCHES. METRIC DIMENSIONS ARE IN BRACKETS.	DRAWN	J.B.K.	92DEC18	tyco Electronics	Tyco Electronics 300 CONSTITUTION DRIVE MENLO PARK, CALIFORNIA 94025 USA		Raychem
	MATERIAL:	/			TITLE		
DECIMALS .XXX ± — { — mm } .XX ± — { — mm }	FINISH:	/			MICRO IN-LINE DATA BUS COUPLER		
ANGLES .X — ± —	CAD NAME	C070005A					
WEIGHT — g { — lbs }	THIRD ANGLE PROJECTION			SIZE	CODE IDENT. NO.	DWG. NO.	REV
		A	06090	D-500-9455-XXXX-XX	C	DO NOT SCALE THIS DRAWING	
						SHEET 1 OF 4	



DETAIL B

(SCALE: NONE)

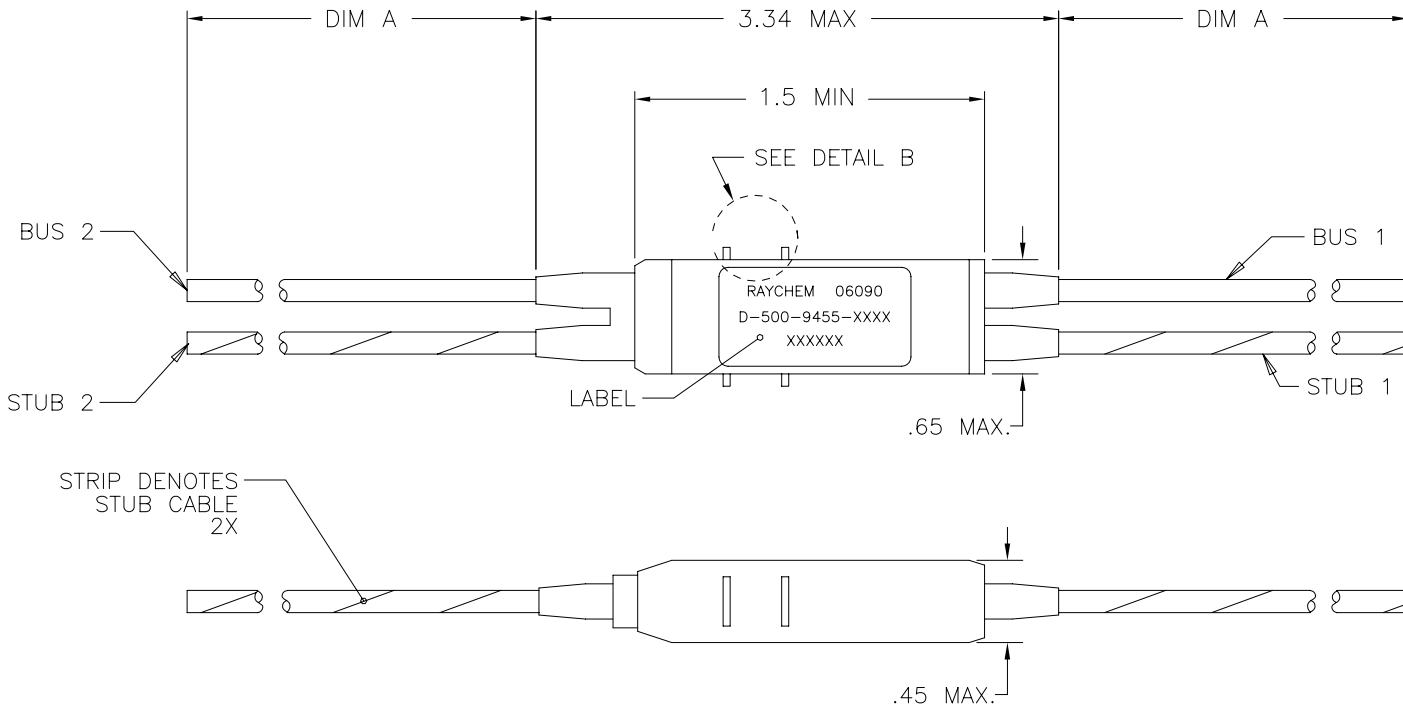
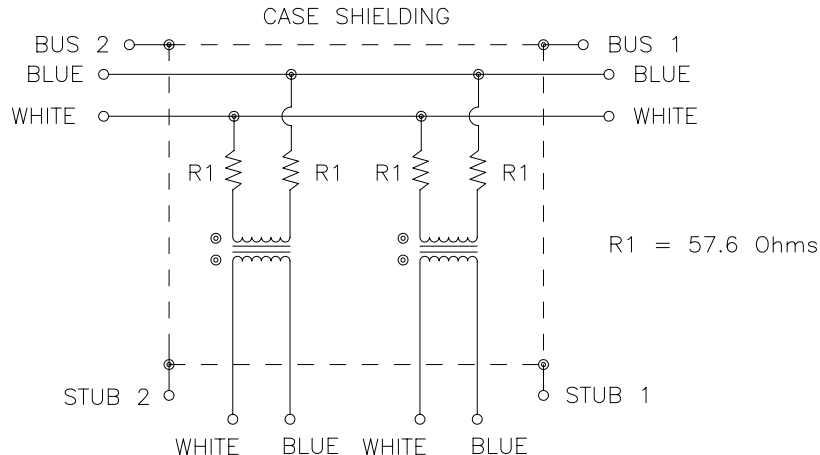
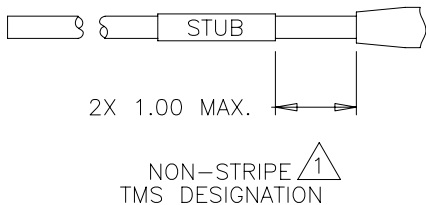

FIGURE 2

(DOUBLE)

D-500-9455-XXXX

DOUBLE STUB COUPLER SCHEMATIC



SPECIFICATION CONTROL DRAWING

© 2007 Tyco Electronics Corporation. All Rights Reserved.

DRAWN J.B.K.	DATE 92DEC18	SIZE A	CODE IDENT. NO. 06090	DWG. NO. D-500-9455-XXXX-XX	REV C
CAD FILE C070005B			DO NOT SCALE THIS DRAWING		SHEET 2 OF 4

1. MATERIAL AND FINISHES:

- 1.1 SHIELDED CASE: ALUMINUM PER ASTM-B618.
- 1.2 SEALED STRAIN RELIEF COVER: MODIFIED CROSS-LINKED ELASTOMER, BLACK, TO RAYCHEM SPECIFICATION RK-6713.
- 1.3 CABLE (SEE CABLE TABULATION, SHEET 4 OF 4). TO RAYCHEM SPECIFICATION 1200.
- ① 1.4 TMS CABLE MARKER: POLYOLEFIN HEAT SHRINKABLE SLEEVE PER RAYCHEM RT-1805.

2. APPLICATION:

- 2.1 THE MICRO IN-LINE COUPLERS ARE DESIGNED TO BE INSTALLED INTO A DIGITAL MULTIPLEX ASSEMBLY MEETING THE REQUIREMENTS OF MIL-STD-1553B.
- 2.2 FOR SYSTEM LAYOUT REQUIREMENTS CONSULT RAYCHEM TECHNICAL SERVICES.
- 2.3 MOUNTING OPTIONS:
 - OPTION 1 TIE INTO HARNESS, PROVIDES TIE DOWN TAB GUIDES PER DETAIL A
 - OPTION 2 SECURE TO BULKHEAD (FIGURE 1A), A SIZE 10 MOUNTING HOLE ($\phi.218\pm.003$) IS PROVIDED IN A MOLDED EYELET. THE SUFFIX "E" DENOTES EYELET.
- 2.3.1 THE DOUBLE STUB COUPLER IS MOUNTED PER OPTION 1 ABOVE.

3. TEMPERATURE:

- 3.1 OPERATING TEMPERATURE: -55°C TO +150°C

4. PERFORMANCE SPECIFICATIONS:

- 4.1 INSTALLED COUPLER MEETS THE PERFORMANCE REQUIREMENTS OF MIL-STD-1553B AND RAYCHEM SPECIFICATION D-6020.
- 4.2 FOR FURTHER REQUIREMENTS AND SPLICE KIT INFORMATION SEE D-500-9455 SCD.

5. WEIGHT:

- 5.1 MAXIMUM WEIGHT WITHOUT CABLE:
 - 10 GRAMS MAX. (SINGLE - MOUNTING OPTION 1)
 - 12 GRAMS MAX. (SINGLE - MOUNTING OPTION 2)
 - 18 GRAMS MAX. (DOUBLE)

6. ORDERING INFORMATION:

ORDER PER TABULATION. (SEE SHEET 4 OF 4) If this document is printed it becomes uncontrolled. Check for the latest revision
CABLE SPLICE KITS TO BE ORDERED SEPARATELY.
SPECIFY CERTIFICATION OF CONFORMANCE REQUIREMENTS AS SEPARATE LINE ITEM.

SPECIFICATION CONTROL DRAWING

© 2007 Tyco Electronics Corporation. All Rights Reserved.

DRAWN	J.B.K.	DATE	92DEC18	SIZE	CODE IDENT. NO.	DWG. NO.	REV
CAD FILE	C070005C			A	06090	D-500-9455-XXXX-XX	C
DO NOT SCALE THIS DRAWING						SHEET 3 OF 4	

NOTES:

 STUB(S) WITHOUT A STRIPE DESIGNATOR WILL BE CALLED OUT BY "STUB" ON A TMS MARKER.

TABULATION

COUPLER (SINGLE)	PCN NO.	CABLE	DIM. A MIN.	COUPLER (DOUBLE)	PCN NO.	CABLE	DIM. A MIN.
D-500-9455-1022	101895	10612	78.0	D-500-9455-1222	062855	10612	78.0
D-500-9455-022-E	547903	10612	78.0				
D-500-9455-022-E-6M	368283	10612	236.0				
D-500-9455-1022-6M	305951	10612	236.0				
D-500-9455-1023	100223	10613	78.0	D-500-9455-1223	738853	10613	78.0
D-500-9455-023-E	252427	10613	78.0				
D-500-9455-1023-6M	896235	10613	236.0				
D-500-9455-1024	857523	10614	78.0	D-500-9455-1224	185601	10614	78.0
D-500-9455-024-E	063861	10614	78.0				
D-500-9455-1024-6M	587863	10614	236.0				

If this document is printed it becomes uncontrolled. Check for the latest revision

SPECIFICATION CONTROL DRAWING

© 2007 Tyco Electronics Corporation. All Rights Reserved.

DRAWN J.B.K.	DATE 92DEC18	SIZE A	CODE IDENT. NO. 06090	DWG. NO. D-500-9455-XXXX-XX	REV C
CAD FILE C070005D			DO NOT SCALE THIS DRAWING		SHEET 4 OF 4