

THIS DRAWING IS UNPUBLISHED. RELEASED FOR PUBLICATION  
 © COPYRIGHT BY TYCO ELECTRONICS CORPORATION. ALL RIGHTS RESERVED.

LOC		DIST		REVISIONS			
P	LTR	DESCRIPTION	DATE	DWN	APVD		
	A	ECO 05 003709	23MAR06	BSV	MS		

SPECIFICATIONS:  
 MAKE-BEFORE-BREAK

MATERIALS:  
 ACTUATOR - NYLON 66 UL94V-0, BLACK  
 FRAME - TIN PLATED STEEL  
 TERMINAL BOARD - PHENOLIC LAMINATE UL94HB, NATURAL  
 TERMINAL (SILVER) - COPPER ALLOY- SILVER OVER NICKEL PLATE  
 TERMINAL (GOLD) - COPPER ALLOY- TIN OVER NICKEL PLATE  
 FIXED CONTACT (SILVER) - COPPER ALLOY- SILVER OVER NICKEL PLATE  
 FIXED CONTACT (GOLD) - COPPER ALLOY-GOLD OVER NICKEL PLATE  
 MOVING CONTACT (SILVER) - COPPER ALLOY- SILVER OVER NICKEL PLATE  
 MOVING CONTACT (GOLD) - COPPER ALLOY-GOLD OVER NICKEL PLATE  
 DETENT BALL - STAINLESS STEEL  
 COIL SPRING - TEMPERED STEEL WIRE  
 SEAL - EPOXY

ELECTRICAL:  
 CONTACT RATING - .4VA@20VDC OR PEAK AC (GOLD)  
 300mA@125V AC (SILVER)  
 INITIAL CONTACT RESISTANCE - 30milliohm max.  
 FINAL CONTACT RESISTANCE - 100milliohm max> (AFTER TEST)  
 INSULATION RESISTANCE - 1,000Megohms min."  
 DIELECTRIC STRENGTH - 500V RMS@SEA LEVEL  
 LIFE EXPECTANCY - 15,000 CYCLES MIN."

MECHANICAL:  
 ACTUATION FORCE - 600±300 GRAMS  
 TRAVEL - 2.00±0.51[.079±.020]

ENVIRONMENTAL:  
 OPERATING TEMPERATURE - -20 TO +85 DEGREES C  
 STORAGE TEMPERATURE - -40 TO +100 DEGREES C  
 RESISTANCE TO SOLDER HEAT PER 109-202, CONDITION B  
 SOLDERABILITY PER EIA- 364-52, CLASS 2, CATEGORY 1, 95% MIN COVERAGE

- NOTES:  
 1. ALL MATERIALS AND FINISHES SHALL COMPLY WITH EU DIRECTIVE 2002 95/EC OF 27JAN2003 (ROHS).  
 2. ANTI SOLDER WICK SEAL AT TERMINAL TO BOARD INTERFACE.

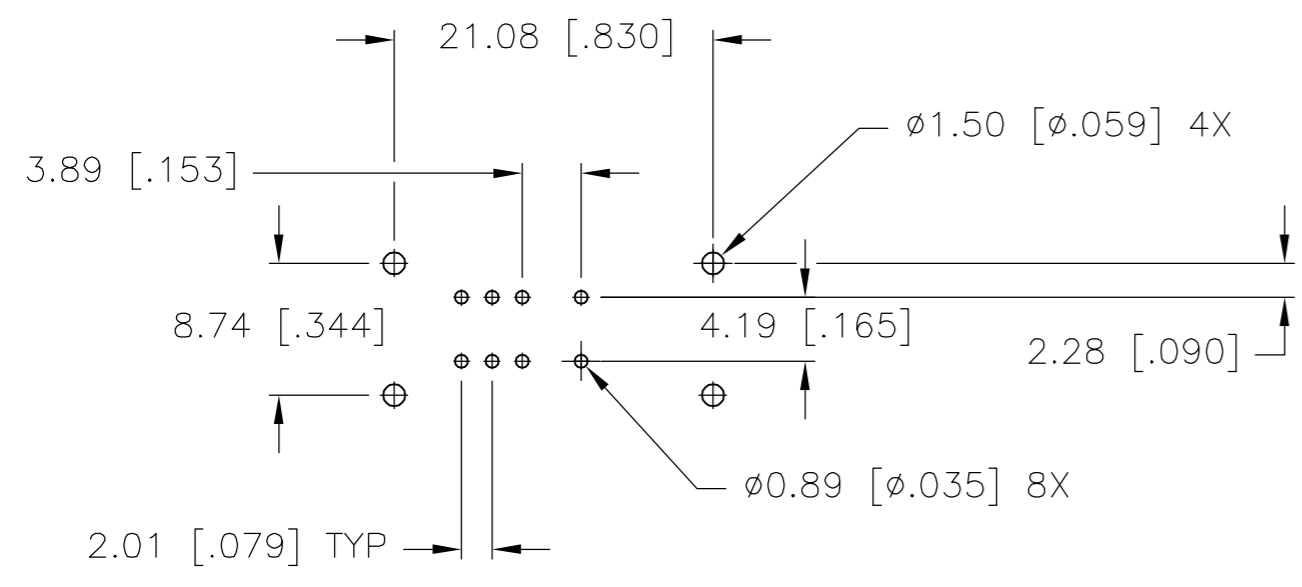
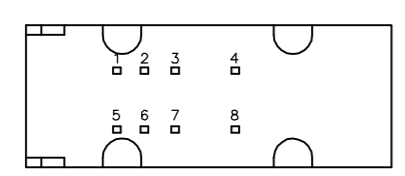
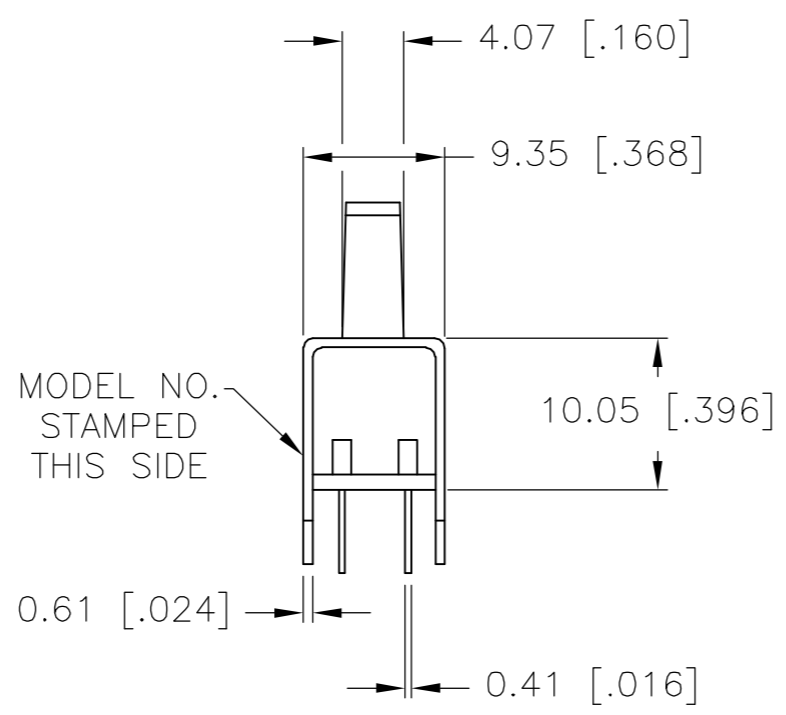
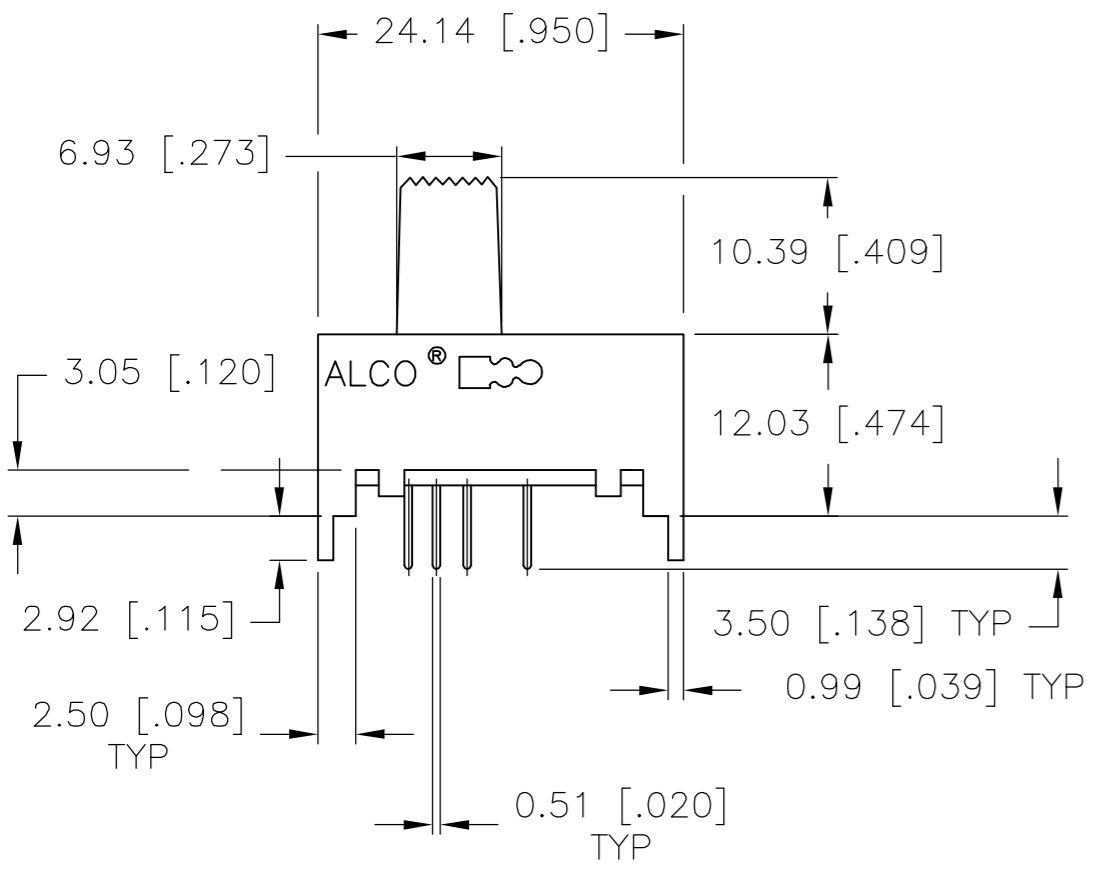
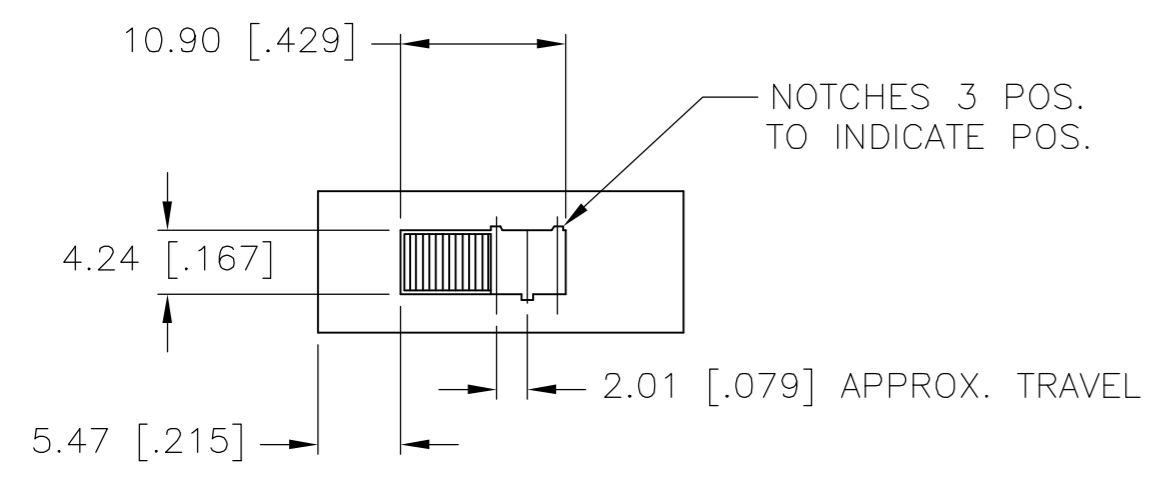

RECOMMENDED HOLE LAYOUT  
 TOLERANCE ±.002 UNLESS OTHERWISE NOTED

1,3&5,7	2,3&6,7	3,4&7,8	DP3T	GOLD	MSSA2350G04	1825198-2
1,3&5,7	2,3&6,7	3,4&7,8	DP3T	SILVER	MSSA235004	1825198-1
			TYPE	CONTACT PLATING	ALCO P/N	TYCO P/N
LEFT CENTER RIGHT			ACTUATOR POSITION			

THIS DRAWING IS A CONTROLLED DOCUMENT.		DWN	TRU-D	20JUN96	<b>tyco</b> Electronics		Tyco Electronics Corporation Harrisburg, PA 17105-3608	
DIMENSIONS: mm [INCHES]		CHK	-	-	NAME		SLIDE SWITCH (MSSA-2350)	
TOLERANCES UNLESS OTHERWISE SPECIFIED:		APVD	-	-	PRODUCT SPEC		APPLICATION SPEC	
0 PLC ± -		WEIGHT	-	-	SIZE	CAGE CODE	DRAWING NO	RESTRICTED TO
1 PLC ± -		MATERIAL		SCALE		SHEET		REV
2 PLC ± 0.25[.010]		SEE SPECIFICATIONS		A2		00779		C=1825198
3 PLC ± -		FINISH		CUSTOMER DRAWING		SCALE		2:1
4 PLC ± -		SEE SPECIFICATIONS		SCALE		SHEET		1 of 1
ANGLES ± -		SEE SPECIFICATIONS		SCALE		SHEET		1 of 1
FINISH		SEE SPECIFICATIONS		SCALE		SHEET		1 of 1
FINISH		SEE SPECIFICATIONS		SCALE		SHEET		1 of 1