

STRAIGHT BULKHEAD JACK PANEL SEAL
SOLDER TYPE - CABLE .141

R125.325.000
SERIES SMA

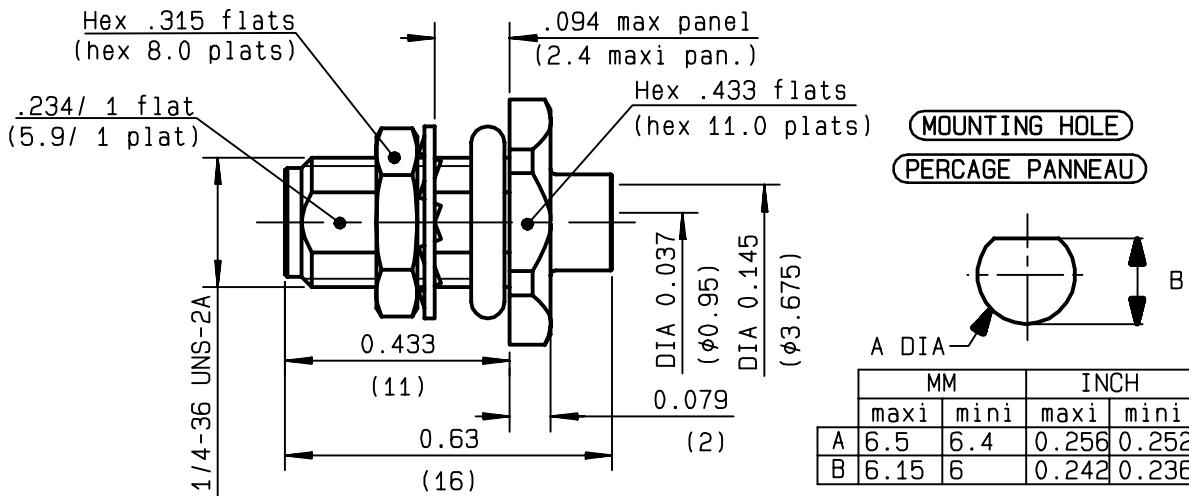

	MM		INCH	
	maxi	mini	maxi	mini
A	6.5	6.4	0.256	0.252
B	6.15	6	0.242	0.236

NOMINAL IMPEDANCE	50 Ω
FREQUENCY RANGE	0-18 GHz
TEMPERATURE RATING	-65/+105 °C
V.S.W.R	1.05 + .008 x F(GHz)Maxi
RF INSERTION LOSS	0.03 √F(GHz) dB Maxi
VOLTAGE RATING	500 Veff Maxi
DIELECTRIC WITHSTANDING VOLTAGE	1000 Veff Mini
INSULATION RESISTANCE	5000 MΩMini
HERMETIC SEAL	NA Atm.cm ³ /s
LEAKAGE (pressurized only)	NA
MECHANICAL DURABILITY	500 Cycles
WEIGHT	gr
SPECIFICATION	

CABLES : **KS 2**
RG 402

OTHERS CHARACTERISTICS

CABLE RETENTION	270	N Mini
CENTER CONTACT RETENTION		
Axial force - mating end	NA	N Mini
Axial force - opposite end	NA	N Mini
Torque	NA	cm.N Mini
RECOMMENDED TORQUES		
Mating	100	cm.N
Panel nut	150	cm.N
Clamp nut	NA	cm.N

CONNECTOR PARTS	MATERIALS	FINISH	(all values are given) in micrometers
BODY	STAINLESS STEEL	GOLD 0.5 OVER NICKEL 2	
OUTER CONTACT			
CENTER CONTACT	BERYLLIUM COPPER	GOLD 1.3 OVER NICKEL 2	
INSULATOR	PTFE	-	
GASKET	SILICONE RUBBER	-	
OTHERS PIECES	BRASS	GOLD 0.2 OVER NICKEL 2	

GUILLOMIN

ISSUE	CREATION DATE	FILE PART-NUMBER
9901H00	06/04/1988	



RADIALL®

The information given here is subject to change without notice.
Design changes may be in order to improve the product .

Connect to the future



R125.325.000

ISSUE **9901H00** SERIES **SMA**

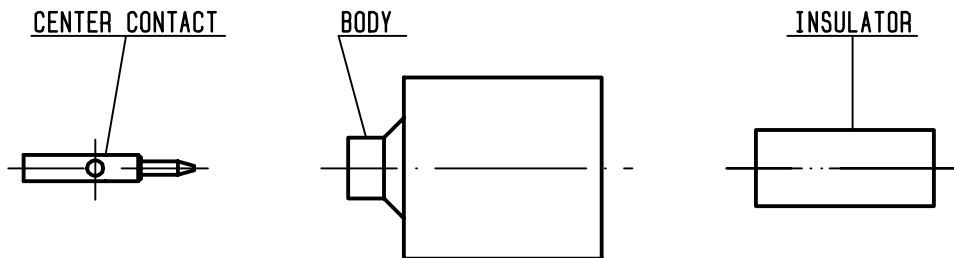

①

Strip the dielectric of the cable with stripping tool R 282 053 000.
 Trimmer : R 282 067 000
 Clean the cable.



Stripping	a	b	c	d	e
inch	0.125	0	0	0	0
mm	3.17				

②

Screw the positioner R 282 744 220 onto the soldering jig R 282 740 000.
 Slide contact into positioner.
 Insert solder gauge R 282 862 060 (62) between contact and cable.
 Tighten and solder the contact .

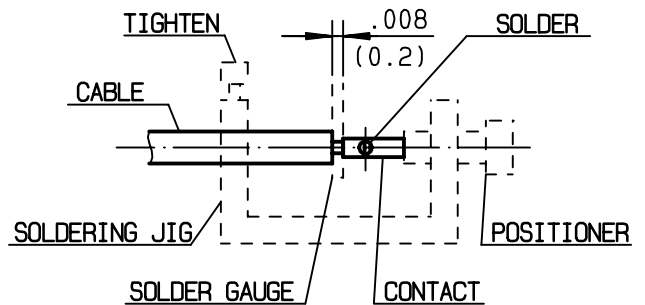

③

After cooling remove cable assembly from the jig.
 Screw positioner R 282 744 011 (86) into the connector.
 Slide cable into the connector until it bottoms against positioner then tighten.
 Put 3 rings of solder around the cable and solder.

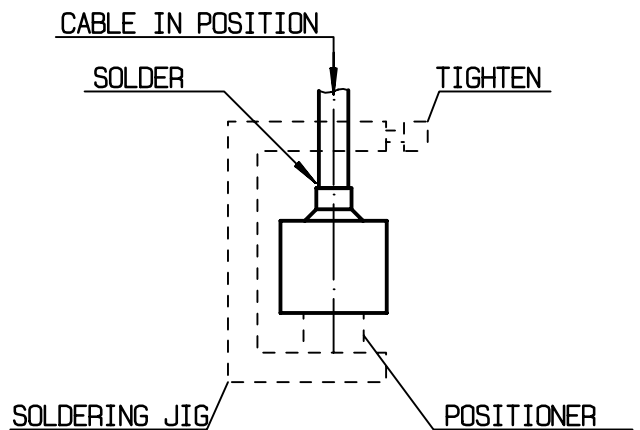

④

After cooling remove cable assembly from the jig.
 Cut the dielectric with dielectric recess gauge R 282 914 010 + R 282 915 010.
 Screw female dielectric insert tool onto connector and insert insulator with the dielectric plunger R 282 730 043.

