

ASSEMBLY - VIEW FROM SIDE

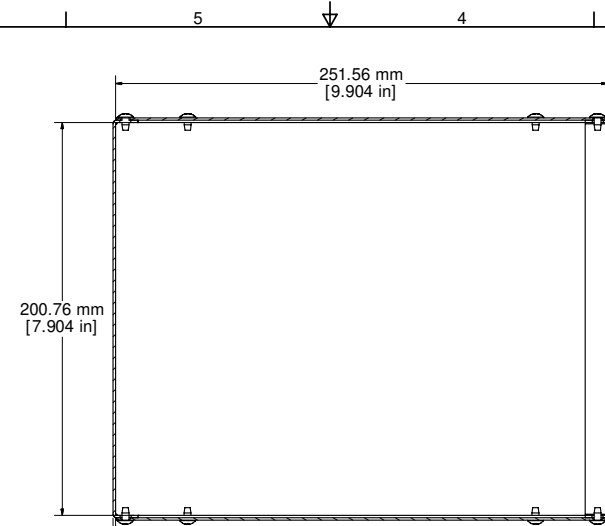

SECTION AA-AA

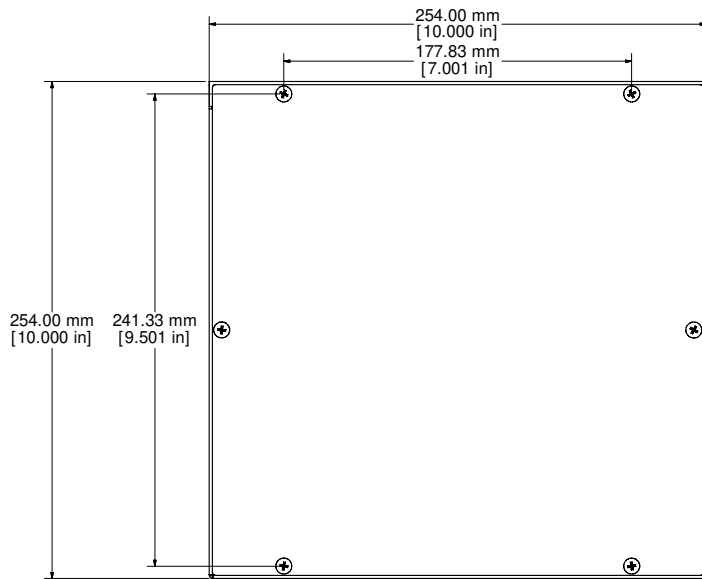

ASSEMBLY - VIEW FROM TOP

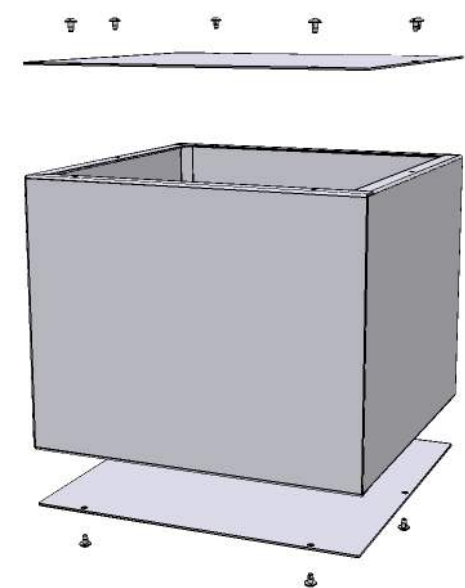

- ASA 61 GREY POWDER PAINTED 0.048" 18 GAUGE STEEL BODY
- TWELVE 6-32 NICKEL PLATED SCREWS
- EXTRA SCREWS - 1421J6 (6-32 x 1/4 SHEET METAL SCREWS)

Contact Factory mjm@hammondmfg.com for quotes
 Enclosures can be Factory Modified (Milling, Drilling, Printing etc.)
 Solid models of this enclosure available in STEP or IGES.



**HAMMOND
 MANUFACTURING™**

1415H

www.hammondmfg.com