

**INSULATED GATE BIPOLAR TRANSISTOR WITH
ULTRAFAST SOFT RECOVERY DIODE**

Features

- Low $V_{CE(on)}$ Trench IGBT Technology
- Low Switching Losses
- 5 μ s SCSOA
- Square RBSOA
- 100% of The Parts Tested for I_{LM} Ⓞ
- Positive $V_{CE(on)}$ Temperature Coefficient.
- Ultra Fast Soft Recovery Co-pak Diode
- Lead-Free, RoHS Compliant
- Automotive Qualified *

Benefits

- High Efficiency in a Wide Range of Applications
- Suitable for a Wide Range of Switching Frequencies due to Low $V_{CE(ON)}$ and Low Switching Losses
- Rugged Transient Performance for Increased Reliability
- Excellent Current Sharing in Parallel Operation
- Low EMI

Applications

- Air Conditioning Compressor
- EV Inverter
- Battery charger
- DC-DC converter

Ordering Information

Base part number	Package Type	Standard Pack		Complete Part Number
		Form	Quantity	
AUIRGP4062D1	TO-247AC	Tube	25	AUIRGP4062D1
AUIRGP4062D1-E	TO-247AD	Tube	25	AUIRGP4062D1-E

Absolute Maximum Ratings

Stresses beyond those listed under "Absolute Maximum Ratings" may cause permanent damage to the device. These are stress ratings only; and functional operation of the device at these or any other condition beyond those indicated in the specifications is not implied. Exposure to absolute-maximum-rated conditions for extended periods may affect device reliability. The thermal resistance and power dissipation ratings are measured under board mounted and still air conditions. Ambient temperature (T_A) is 25°C, unless otherwise specified

	Parameter	Max.	Units	
V_{CES}	Collector-to-Emitter Voltage	600	V	
$I_C @ T_C = 25^\circ C$	Continuous Collector Current	55	A	
$I_C @ T_C = 100^\circ C$	Continuous Collector Current	36		
$I_{NOMINAL}$	Nominal Current	24		
I_{CM}	Pulse Collector Current, $V_{GE} = 15V$	72		
I_{LM}	Clamped Inductive Load Current, $V_{GE} = 20V$ Ⓞ	96		
$I_F @ T_C = 25^\circ C$	Diode Continuous Forward Current	55		
$I_F @ T_C = 100^\circ C$	Diode Continuous Forward Current	36		
I_{FM}	Diode Maximum Forward Current Ⓜ	96		
V_{GE}	Continuous Gate-to-Emitter Voltage	± 20		V
	Transient Gate-to-Emitter Voltage	± 30		
$P_D @ T_C = 25^\circ C$	Maximum Power Dissipation	217	W	
$P_D @ T_C = 100^\circ C$	Maximum Power Dissipation	109		
T_J T_{STG}	Operating Junction and Storage Temperature Range	-55 to +175	°C	
	Soldering Temperature, for 10 sec. (1.6mm from case)	300		
	Mounting Torque, 6-32 or M3 Screw	10 lbf·in (1.1N·m)		

Thermal Resistance

	Parameter	Min.	Typ.	Max.	Units
$R_{\theta JC}$ (IGBT)	Thermal Resistance Junction-to-Case (IGBT)Ⓜ	---	---	0.69	°C/W
$R_{\theta JC}$ (Diode)	Thermal Resistance Junction-to-Case (Diode)Ⓜ	---	---	1.2	
$R_{\theta CS}$	Thermal Resistance, Case-to-Sink (flat, greased surface)	---	0.24	---	
$R_{\theta JA}$	Thermal Resistance, Junction-to-Ambient	---	40	---	

*Qualification standards can be found at <http://www.irf.com/>

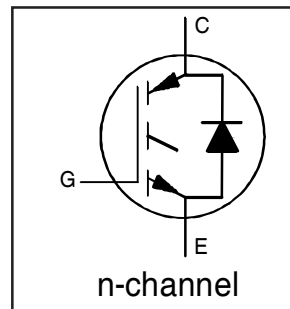

$V_{CES} = 600V$
$I_{C(Nominal)} = 24A$
$t_{SC} \geq 5\mu s, T_{J(max)} = 175^\circ C$
$V_{CE(on)} \text{ typ.} = 1.57V$

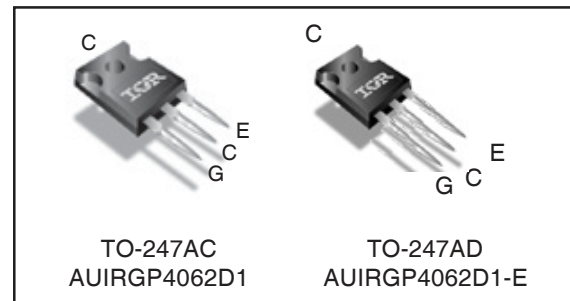

G	C	E
Gate	Collector	Emitter

Electrical Characteristics @ T_J = 25°C (unless otherwise specified)

	Parameter	Min.	Typ.	Max.	Units	Conditions
V _{(BR)CES}	Collector-to-Emitter Breakdown Voltage	600	—	—	V	V _{GE} = 0V, I _C = 100μA ④
ΔV _{(BR)CES} /ΔT _J	Temperature Coeff. of Breakdown Voltage	—	0.3	—	V/°C	V _{GE} = 0V, I _C = 10mA (25°C-175°C)
V _{CE(on)}	Collector-to-Emitter Saturation Voltage	—	1.57	1.77	V	I _C = 24A, V _{GE} = 15V, T _J = 25°C
		—	1.87	—		I _C = 24A, V _{GE} = 15V, T _J = 150°C
		—	1.94	—		I _C = 24A, V _{GE} = 15V, T _J = 175°C
V _{GE(th)}	Gate Threshold Voltage	4.0	—	6.5	V	V _{CE} = V _{GE} , I _C = 700μA
ΔV _{GE(th)} /ΔT _J	Threshold Voltage temp. coefficient	—	-17	—	mV/°C	V _{CE} = V _{GE} , I _C = 1.0mA (25°C - 175°C)
g _f	Forward Transconductance	—	12	—	S	V _{CE} = 50V, I _C = 24A, P _W = 20μs
I _{CES}	Collector-to-Emitter Leakage Current	—	1.0	25	μA	V _{GE} = 0V, V _{CE} = 600V
		—	3.5	—	mA	V _{GE} = 0V, V _{CE} = 600V, T _J = 175°C
V _{FM}	Diode Forward Voltage Drop	—	1.57	—	V	I _F = 24A
		—	1.40	—		I _F = 19A
		—	1.47	—		I _F = 24A, T _J = 175°C
I _{GES}	Gate-to-Emitter Leakage Current	—	—	±100	nA	V _{GE} = ±20V

Switching Characteristics @ T_J = 25°C (unless otherwise specified)

	Parameter	Min.	Typ.	Max.	Units	Conditions
Q _g	Total Gate Charge (turn-on)	—	51	77	nC	I _C = 24A
Q _{ge}	Gate-to-Emitter Charge (turn-on)	—	14	21		V _{GE} = 15V
Q _{gc}	Gate-to-Collector Charge (turn-on)	—	21	32		V _{CC} = 400V
E _{on}	Turn-On Switching Loss	—	532	754	μJ	I _C = 24A, V _{CC} = 400V, V _{GE} = 15V
E _{off}	Turn-Off Switching Loss	—	311	526		R _G = 10Ω, L = 210μH, T _J = 25°C
E _{total}	Total Switching Loss	—	843	1280		Energy losses include tail & diode reverse recovery
t _{d(on)}	Turn-On delay time	—	19	36	ns	I _C = 24A, V _{CC} = 400V, V _{GE} = 15V
t _r	Rise time	—	24	41		R _G = 10Ω, L = 210μH, T _J = 25°C
t _{d(off)}	Turn-Off delay time	—	90	109		
t _f	Fall time	—	23	40		
E _{on}	Turn-On Switching Loss	—	726	—	μJ	I _C = 24A, V _{CC} = 400V, V _{GE} = 15V
E _{off}	Turn-Off Switching Loss	—	549	—		R _G = 10Ω, L = 210μH, T _J = 175°C ④
E _{total}	Total Switching Loss	—	1275	—		Energy losses include tail & diode reverse recovery
t _{d(on)}	Turn-On delay time	—	12	—	ns	I _C = 24A, V _{CC} = 400V, V _{GE} = 15V
t _r	Rise time	—	23	—		R _G = 10Ω, L = 200μH, L _S = 150nH
t _{d(off)}	Turn-Off delay time	—	92	—		T _J = 175°C
t _f	Fall time	—	84	—		
C _{ies}	Input Capacitance	—	1487	—	pF	V _{GE} = 0V
C _{oes}	Output Capacitance	—	118	—		V _{CC} = 30V
C _{res}	Reverse Transfer Capacitance	—	44	—		f = 1.0Mhz
RBSOA	Reverse Bias Safe Operating Area	FULL SQUARE				T _J = 175°C, I _C = 96A V _{CC} = 480V, V _p ≤ 600V R _G = 10Ω, V _{GE} = +20V to 0V
SCSOA	Short Circuit Safe Operating Area	5	—	—	μs	V _{CC} = 400V, V _p ≤ 600V R _G = 10Ω, V _{GE} = +15V to 0V
E _{rec}	Reverse Recovery Energy of the Diode	—	773	—	μJ	T _J = 175°C
t _{rr}	Diode Reverse Recovery Time	—	102	—	ns	V _{CC} = 400V, I _F = 24A
I _{rr}	Peak Reverse Recovery Current	—	32	—	A	V _{GE} = 15V, R _G = 10Ω, L = 210μH

Notes:

- ① V_{CC} = 80% (V_{CES}), V_{GE} = 20V, L = 210μH, R_G = 50Ω.
- ② Pulse width limited by max. junction temperature.
- ③ R_θ is measured at T_J of approximately 90°C.
- ④ Maximum limits are based on statistical sample size characterization.

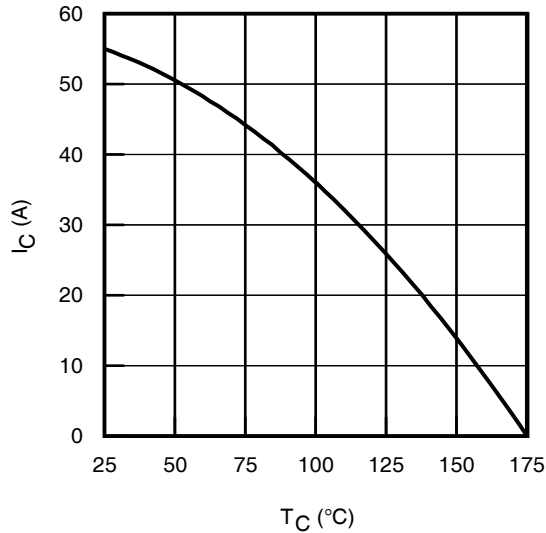

Fig. 1 - Maximum DC Collector Current vs. Case Temperature

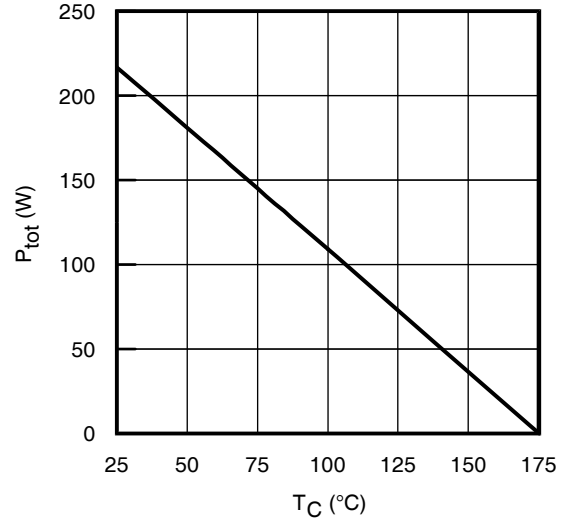

Fig. 2 - Power Dissipation vs. Case Temperature

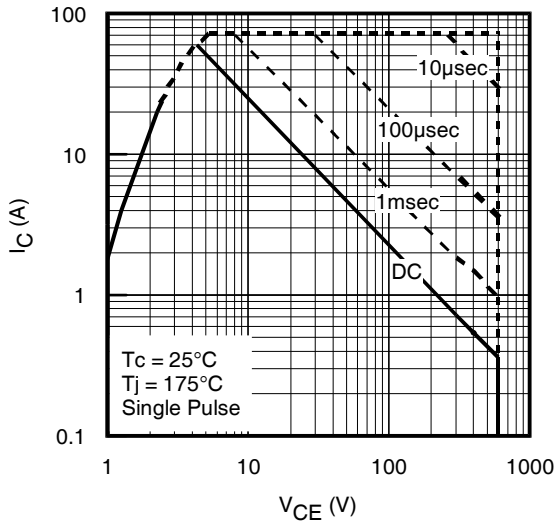

Fig. 3 - Forward SOA
 $T_C = 25^\circ\text{C}$, $T_J \leq 175^\circ\text{C}$; $V_{GE} = 15\text{V}$

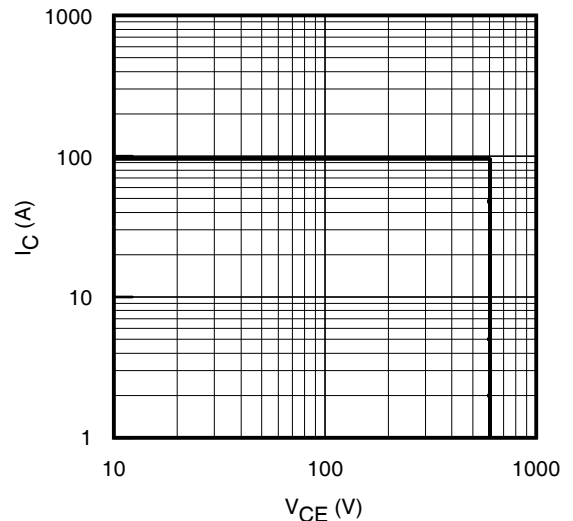

Fig. 4 - Reverse Bias SOA
 $T_J = 175^\circ\text{C}$; $V_{GE} = 20\text{V}$

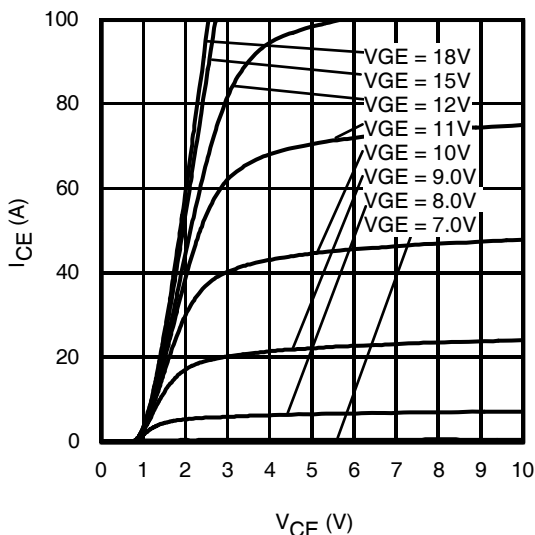

Fig. 5 - Typ. IGBT Output Characteristics
 $T_J = -40^\circ\text{C}$; $t_p = 20\mu\text{s}$

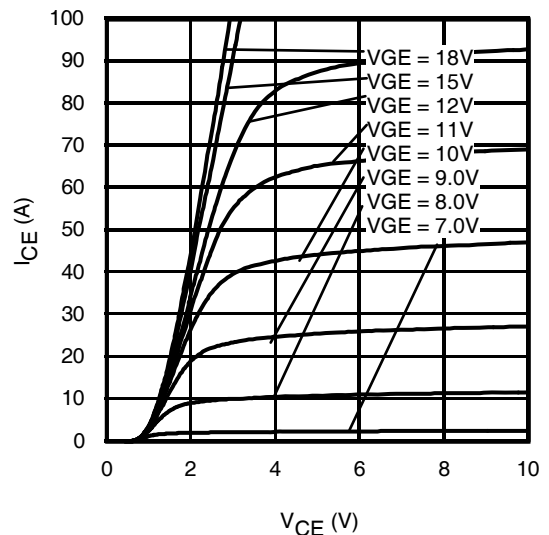

Fig. 6 - Typ. IGBT Output Characteristics
 $T_J = 25^\circ\text{C}$; $t_p = 20\mu\text{s}$

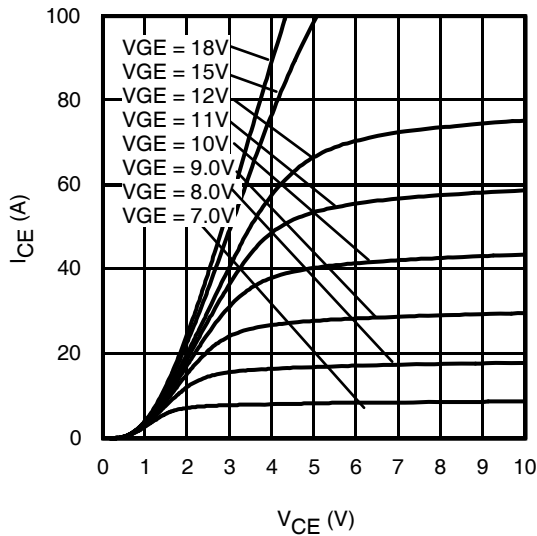

Fig. 7 - Typ. IGBT Output Characteristics
 $T_J = 175^\circ\text{C}$; $t_p = 20\mu\text{s}$

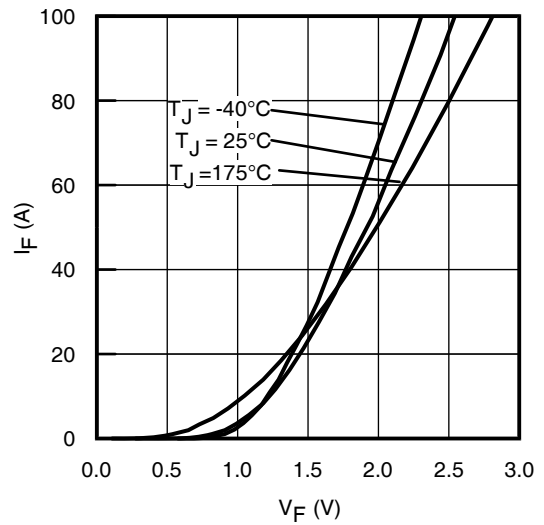

Fig. 8 - Typ. Diode Forward Characteristics
 $t_p = 20\mu\text{s}$

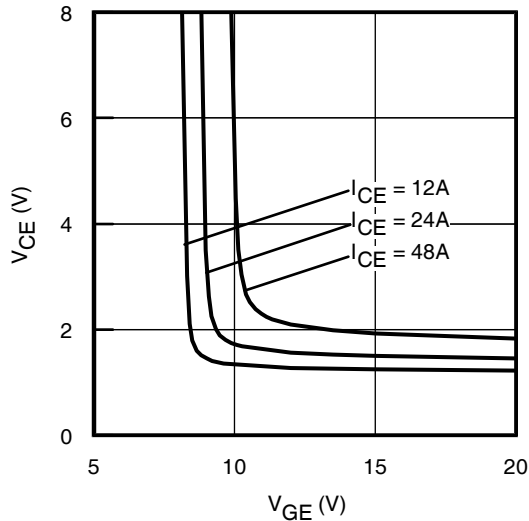

Fig. 9 - Typical V_{CE} vs. V_{GE}
 $T_J = -40^\circ\text{C}$

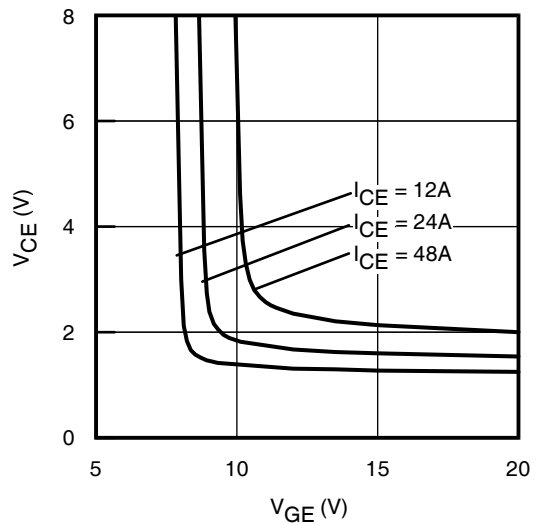

Fig. 10 - Typical V_{CE} vs. V_{GE}
 $T_J = 25^\circ\text{C}$

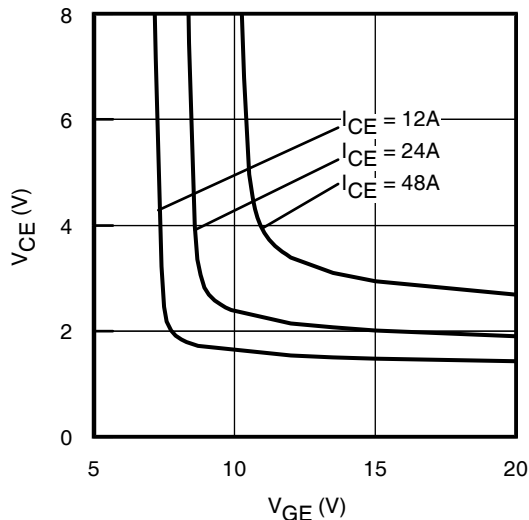

Fig. 11 - Typical V_{CE} vs. V_{GE}
 $T_J = 175^\circ\text{C}$

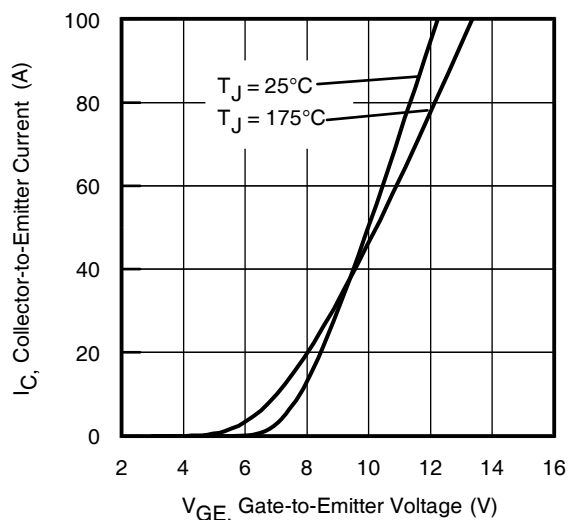
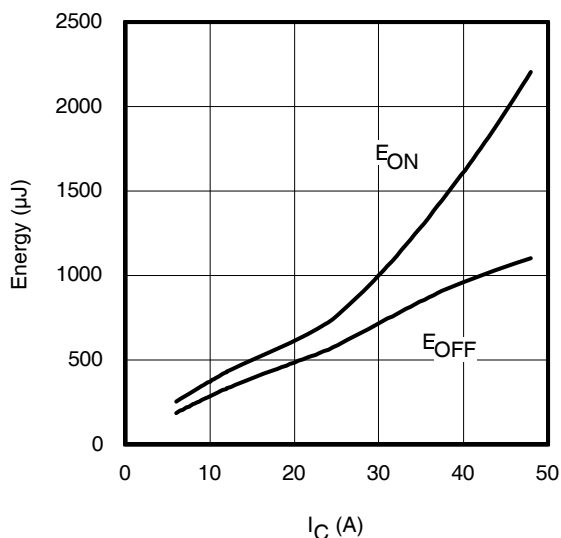
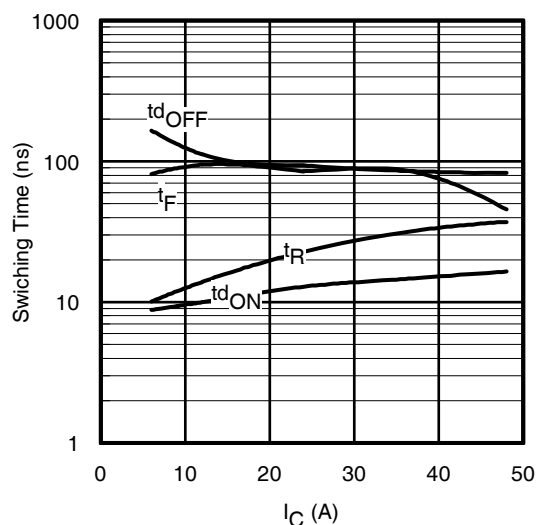
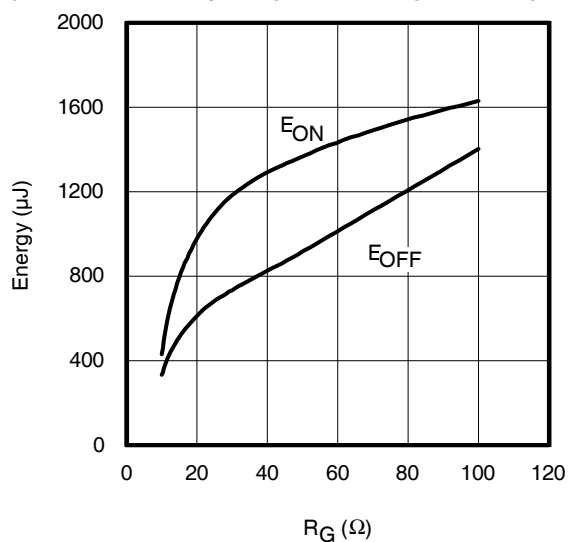
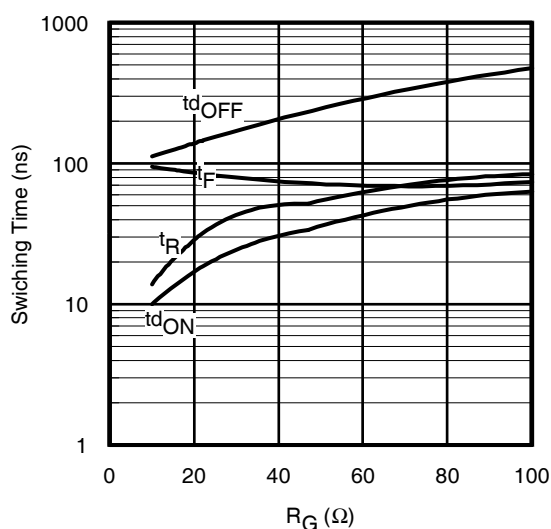
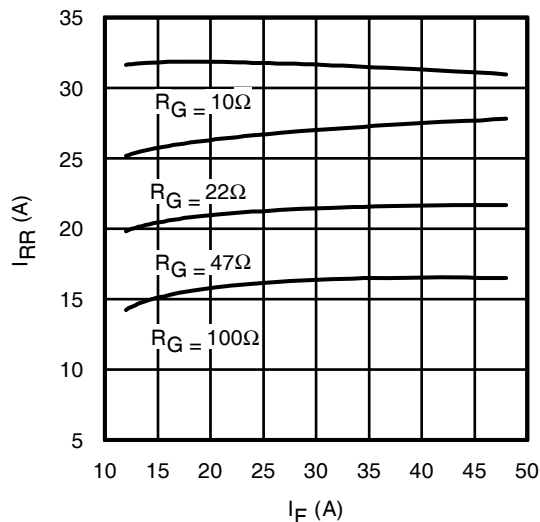
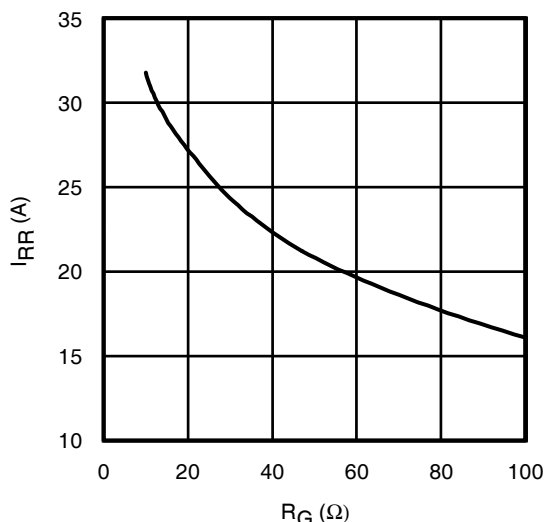

Fig. 12 - Typ. Transfer Characteristics
 $V_{CE} = 50\text{V}$; $t_p = 20\mu\text{s}$

Fig. 13 - Typ. Energy Loss vs. I_C
 $T_J = 175^\circ\text{C}; L = 210\mu\text{H}; V_{CE} = 400\text{V}, R_G = 10\Omega; V_{GE} = 15\text{V}$

Fig. 14 - Typ. Switching Time vs. I_C
 $T_J = 175^\circ\text{C}; L = 210\mu\text{H}; V_{CE} = 400\text{V}, R_G = 10\Omega; V_{GE} = 15\text{V}$

Fig. 15 - Typ. Energy Loss vs. R_G
 $T_J = 175^\circ\text{C}; L = 210\mu\text{H}; V_{CE} = 400\text{V}, I_{CE} = 24\text{A}; V_{GE} = 15\text{V}$

Fig. 16 - Typ. Switching Time vs. R_G
 $T_J = 175^\circ\text{C}; L = 210\mu\text{H}; V_{CE} = 400\text{V}, I_{CE} = 24\text{A}; V_{GE} = 15\text{V}$

Fig. 17 - Typ. Diode I_{RR} vs. I_F
 $T_J = 175^\circ\text{C}$

Fig. 18 - Typ. Diode I_{RR} vs. R_G
 $T_J = 175^\circ\text{C}$

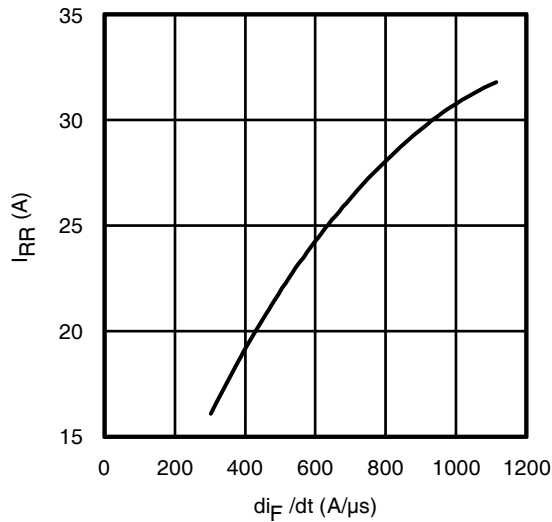

Fig. 19 - Typ. Diode I_{RR} vs. di_F/dt
 $V_{CC} = 400V$; $V_{GE} = 15V$; $I_F = 24A$; $T_J = 175^\circ C$

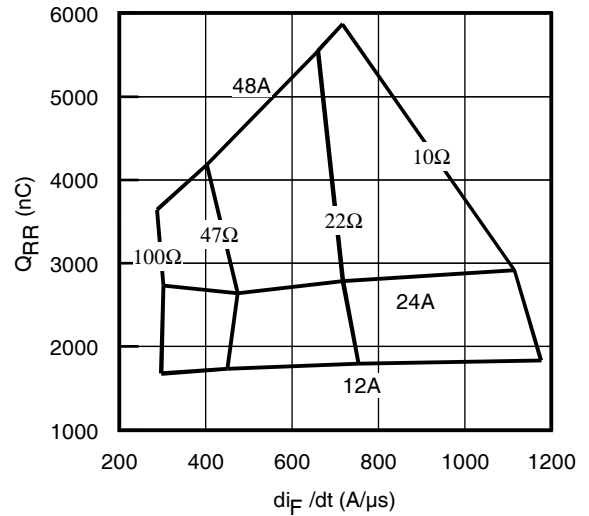

Fig. 20 - Typ. Diode Q_{RR} vs. di_F/dt
 $V_{CC} = 400V$; $V_{GE} = 15V$; $T_J = 175^\circ C$

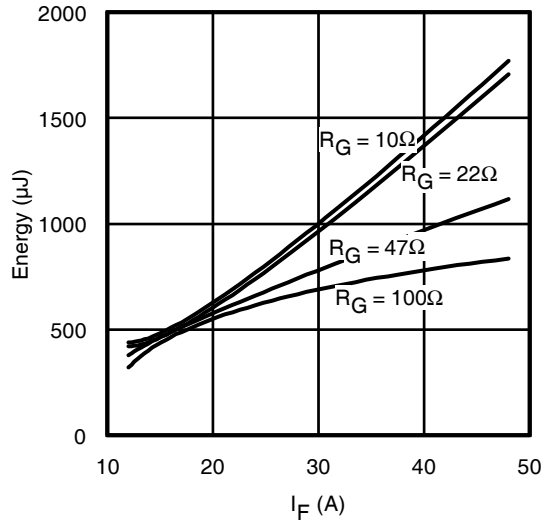

Fig. 21 - Typ. Diode E_{RR} vs. I_F
 $T_J = 175^\circ C$

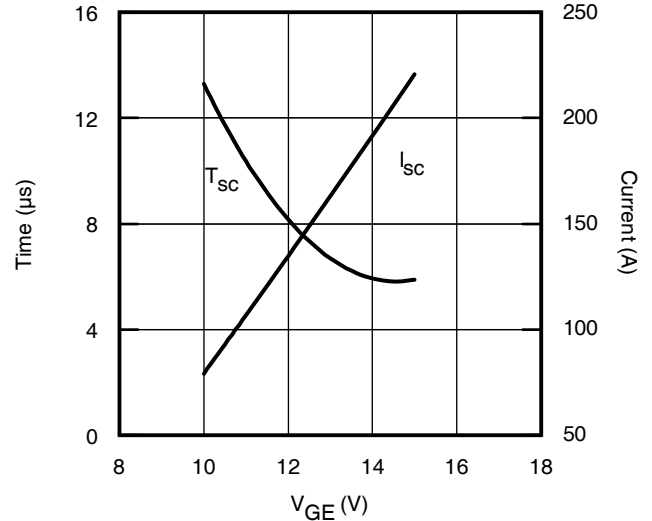

Fig. 22 - V_{GE} vs. Short Circuit Time
 $V_{CC} = 400V$; $T_C = 25^\circ C$

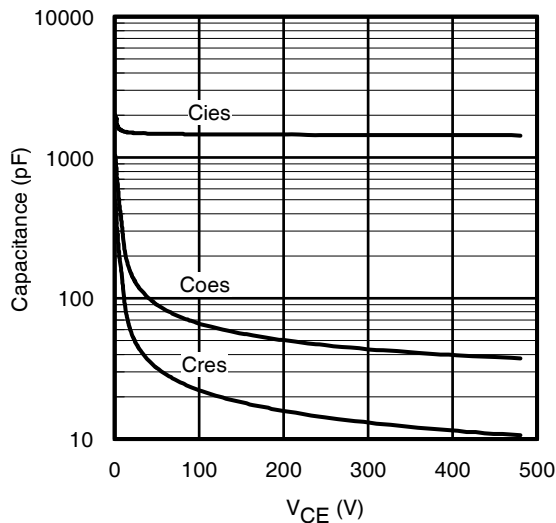

Fig. 23 - Typ. Capacitance vs. V_{CE}
 $V_{GE} = 0V$; $f = 1MHz$

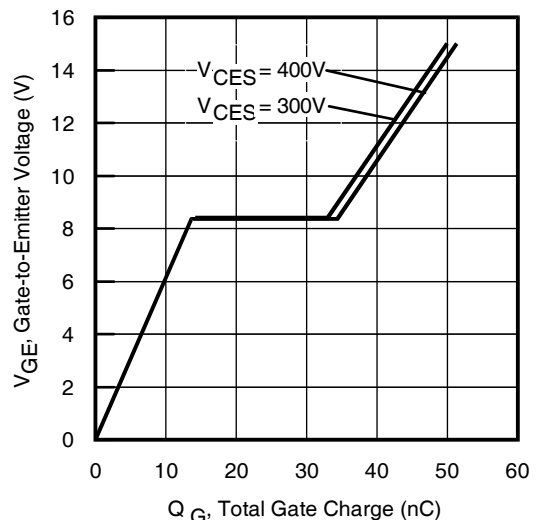
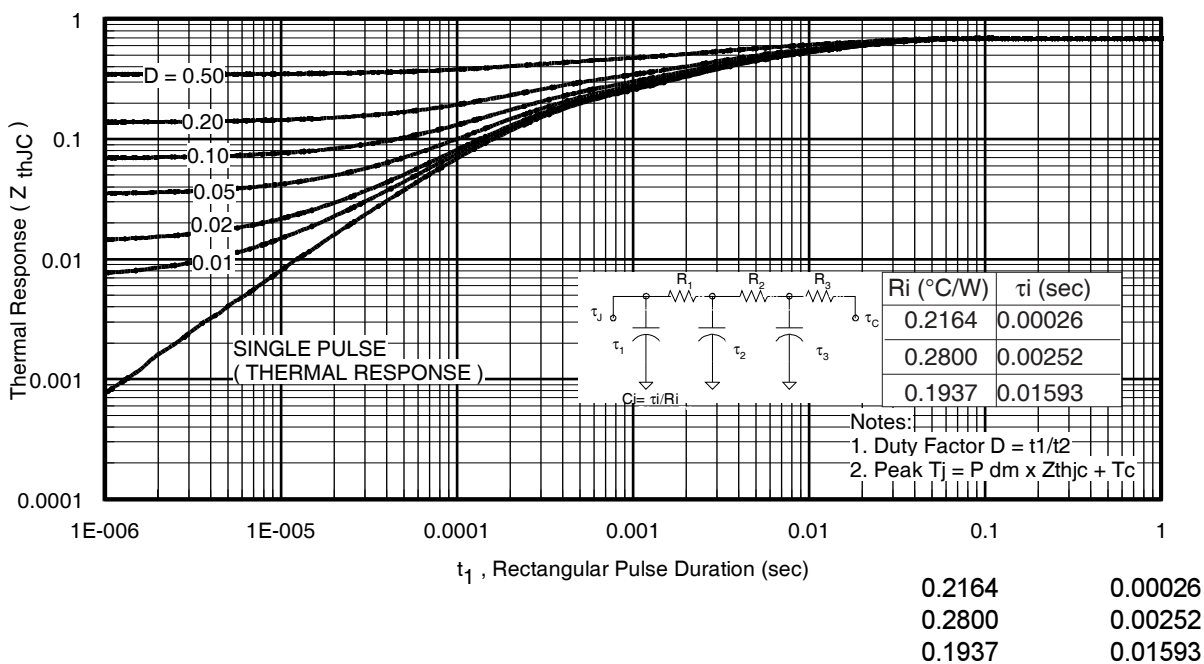
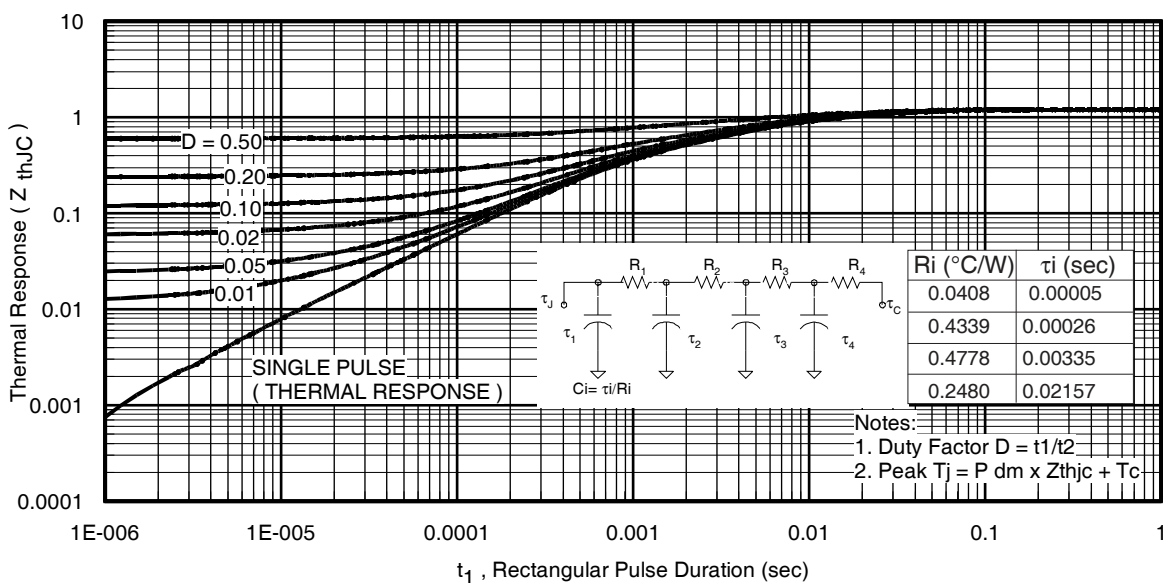

Fig. 24 - Typical Gate Charge vs. V_{GE}
 $I_{CE} = 24A$; $L = 585\mu H$

Fig 25. Maximum Transient Thermal Impedance, Junction-to-Case (IGBT)

Fig. 26. Maximum Transient Thermal Impedance, Junction-to-Case (DIODE)

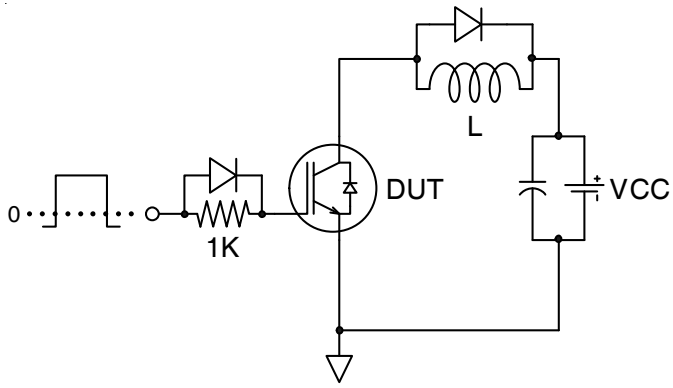

Fig.C.T.1 - Gate Charge Circuit (turn-off)

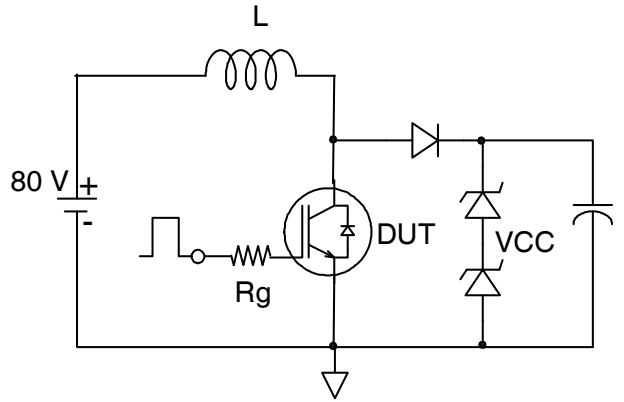
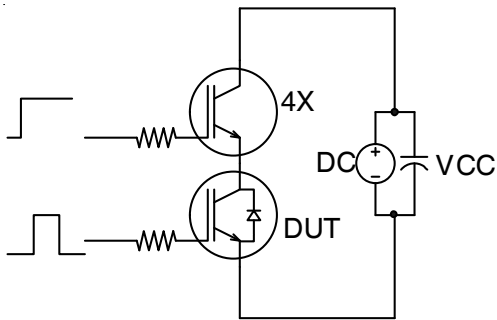

Fig.C.T.2 - RBSOA Circuit



SCSOA

Fig.C.T.3 - S.C. SOA Circuit

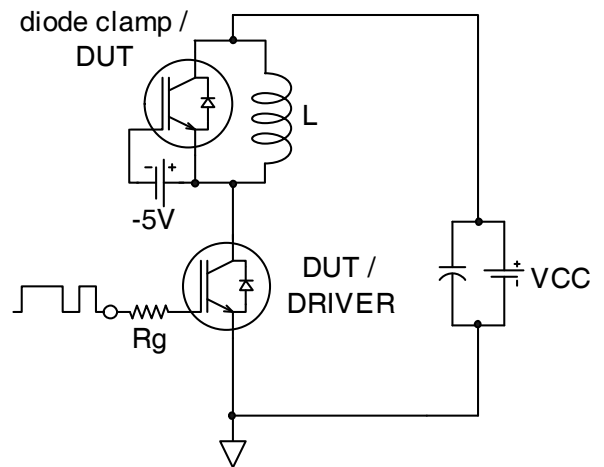

Fig.C.T.4 - Switching Loss Circuit

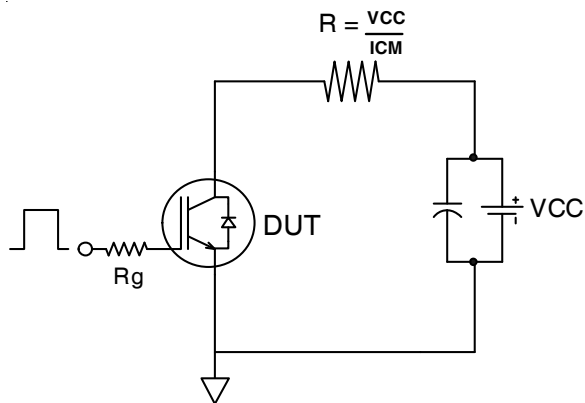

Fig.C.T.5 - Resistive Load Circuit

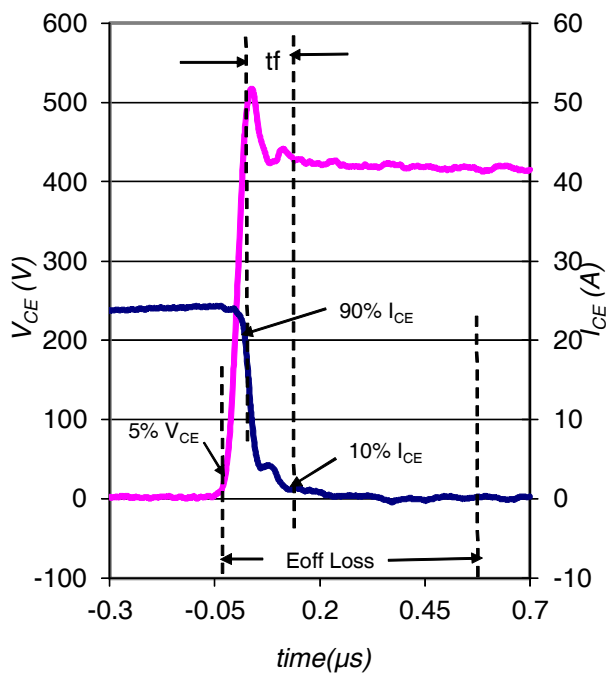

Fig. WF1 - Typ. Turn-off Loss Waveform
@ $T_J = 175^\circ\text{C}$ using Fig. CT.4

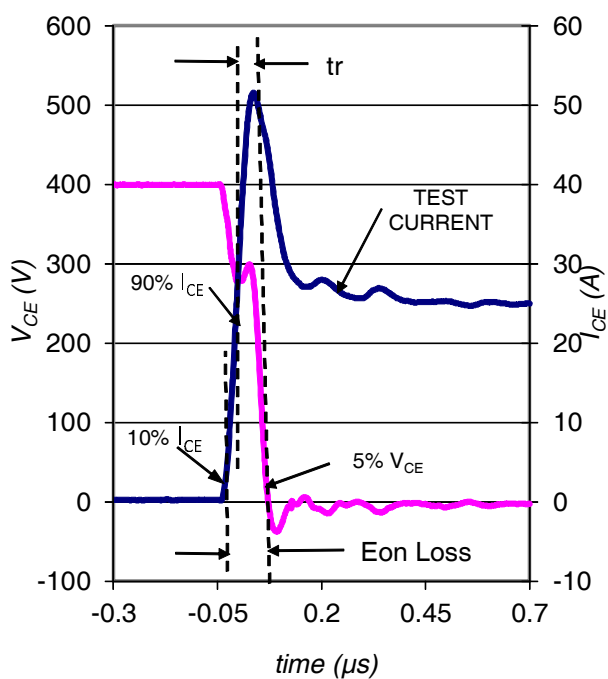

Fig. WF2 - Typ. Turn-on Loss Waveform
@ $T_J = 175^\circ\text{C}$ using Fig. CT.4

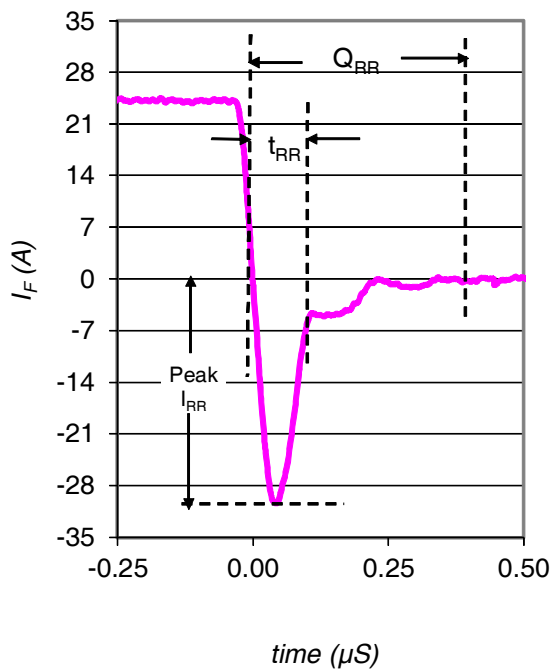

Fig. WF3 - Typ. Diode Recovery Waveform
@ $T_J = 175^\circ\text{C}$ using Fig. CT.4

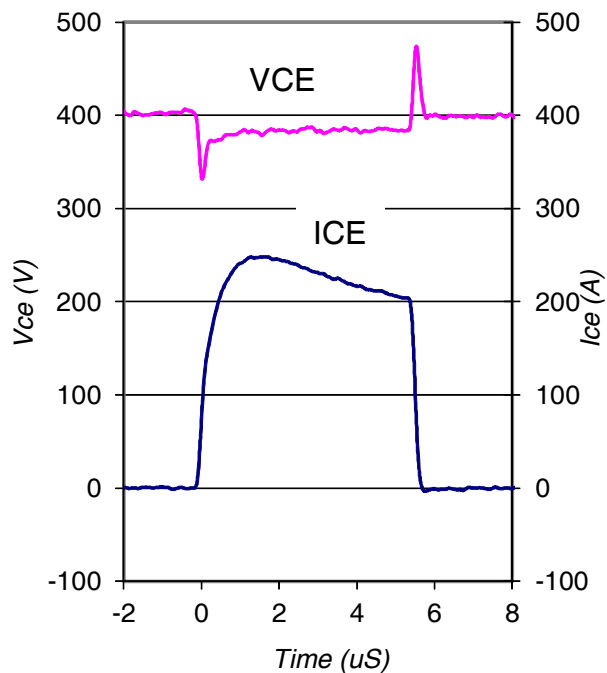
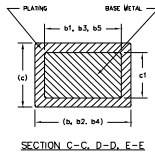
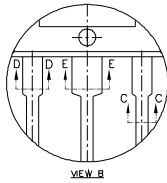
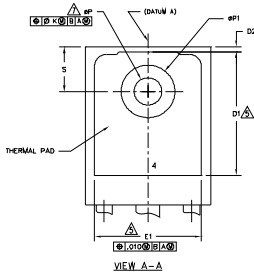
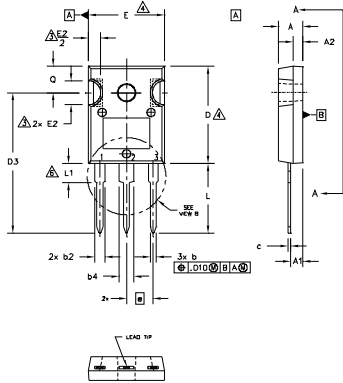

Fig. WF4 - Typ. S.C. Waveform
@ $T_J = 25^\circ\text{C}$ using Fig. CT.3

TO-247AC Package Outline

Dimensions are shown in millimeters (inches)



NOTES:

1. DIMENSIONING AND TOLERANCING AS PER ASME Y14.5M 1994.
2. DIMENSIONS ARE SHOWN IN INCHES.
3. CONTOUR OF SLOT OPTIONAL.
4. DIMENSION D & E DO NOT INCLUDE MOLD FLASH. MOLD FLASH SHALL NOT EXCEED .005" (0.127) PER SIDE. THESE DIMENSIONS ARE MEASURED AT THE OUTERMOST EXTREMES OF THE PLASTIC BODY.
5. THERMAL PAD CONTOUR OPTIONAL WITHIN DIMENSIONS D1 & E1.
6. LEAD FINISH UNCONTROLLED IN L1.
7. ØP TO HAVE A MAXIMUM DRAFT ANGLE OF 1.5 ° TO THE TOP OF THE PART WITH A MAXIMUM HOLE DIAMETER OF .154 INCH.
8. OUTLINE CONFORMS TO JEDEC OUTLINE TO-247AC .

SYMBOL	DIMENSIONS				NOTES
	INCHES		MILLIMETERS		
	MIN.	MAX.	MIN.	MAX.	
A	.183	.209	4.65	5.31	
A1	.087	.102	2.21	2.59	
A2	.059	.098	1.50	2.49	
b	.039	.055	0.99	1.40	
b1	.039	.053	0.99	1.35	
b2	.065	.094	1.65	2.39	
b3	.065	.092	1.65	2.34	
b4	.102	.135	2.59	3.43	
b5	.102	.133	2.59	3.38	
c	.015	.035	0.38	0.89	
c1	.015	.033	0.38	0.84	
D	.776	.815	19.71	20.70	4
D1	.515	-	13.08	-	5
D2	.020	.053	0.51	1.35	
D3	1.122	1.161	28.50	29.50	4
E	.602	.625	15.29	15.87	
E1	.530	-	13.46	-	
E2	.178	.216	4.52	5.49	
e	.215 BSC		5.46 BSC		
Øk	.010		0.25		
L	.559	.634	14.20	16.10	
L1	.146	.169	3.71	4.29	
ØP	.140	.144	3.56	3.66	
ØP1	-	.291	-	7.39	
Q	.209	.224	5.31	5.69	
S	.217 BSC		5.51 BSC		

PART NUMBERS AFFECTED:

- AUIRGP4PH50S
- AUIRGP4066D1/E
- AUIRGP4063D/E
- AUIRGP50B60PD1/E
- AUIRGP35B60PD/E
- AUIRGP4062D1/E
- AUIRGP6542D0D
- AUIRGP6520D0
- AUIRGP/F66524D0
- AUIRGP/F76524D0
- AUIRGP/F66548D0
- AUIRGP/F76548D0

LEAD ASSIGNMENTS

HEXFET

- 1.- GATE
- 2.- DRAIN
- 3.- SOURCE
- 4.- DRAIN

IGBTs, CoPACK

- 1.- GATE
- 2.- COLLECTOR
- 3.- EMITTER
- 4.- COLLECTOR

DIODES

- 1.- ANODE/OPEN
- 2.- CATHODE
- 3.- ANODE

SPECIAL NOTE:

- a) ADDED D3 FOR SPECIAL REQUIREMENT

TO-247AC Part Marking Information

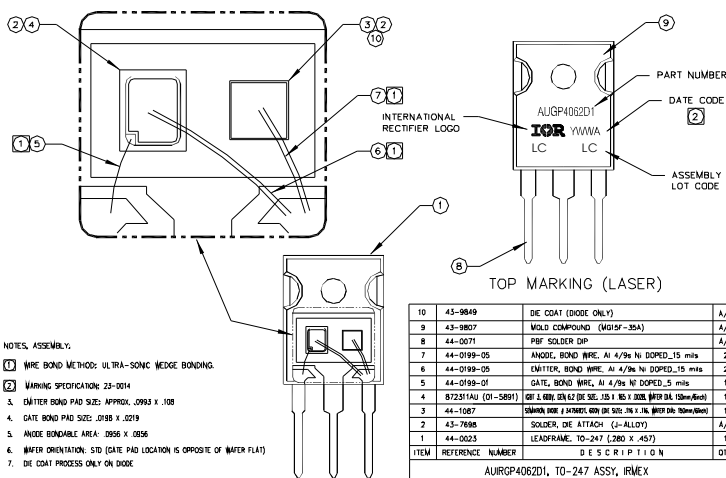

- NOTES, ASSEMBLY:**
1. WIRE BOND METHOD: ULTRA-SONIC WEDGE BONDING
 2. MARKING SPECIFICATION: 23-0014
 3. EMITTER BOND PAD SIZE: APPROX. .0983 x .108
 4. GATE BOND PAD SIZE: .098 x .0219
 5. ANODE BONDABLE AREA: .0958 x .0556
 6. WATER ORIENTATION: STD (GATE PAD LOCATION IS OPPOSITE OF WATER FLAT)
 7. DIE COAT PROCESS ONLY ON DIE

ITEM	REFERENCE NUMBER	DESCRIPTION	QTY
10	43-9849	DIE COAT (DIODE ONLY)	A/R
9	43-9807	MOLD COMPOUND (M012F-35A)	A/R
8	44-0071	PBF SOLDER DP	A/R
7	44-0199-05	ANGLED BOND WIRE, Al 4/96 Ni DOPED .15 mts	2
6	44-0199-05	EMITTER BOND WIRE, Al 4/96 Ni DOPED .15 mts	2
5	44-0199-01	GATE BOND WIRE, Al 4/96 Ni DOPED .5 mts	1
4	872317AU (01-5897)	ØP ± .001, ØP1 ± .002, ØP2 ± .002, ØP3 ± .002, ØP4 ± .002, ØP5 ± .002, ØP6 ± .002, ØP7 ± .002, ØP8 ± .002, ØP9 ± .002, ØP10 ± .002	A/R
3	44-1187	WIRE BOND WIRE, ØP ± .001, ØP1 ± .002, ØP2 ± .002, ØP3 ± .002, ØP4 ± .002, ØP5 ± .002, ØP6 ± .002, ØP7 ± .002, ØP8 ± .002, ØP9 ± .002, ØP10 ± .002	1
2	43-7698	SOLDER, DIE ATTACH (2-ALLOY)	A/R
1	44-0023	LEADFRAME, TO-247 (280 X .457)	1
TOTAL			1
AUIRGP4062D1, TO-247 ASSY, IRVEX			QTY

NOTES, PACKAGING:
1. TUBE - 25 UNITS/TUBE

ALL DIMENSIONS ARE SHOWN IN INCHES [MILLIMETERS]

Note: For the most current drawing please refer to IR website at <http://www.irf.com/package/>

TO-247AD Package Outline

Dimensions are shown in millimeters (inches)

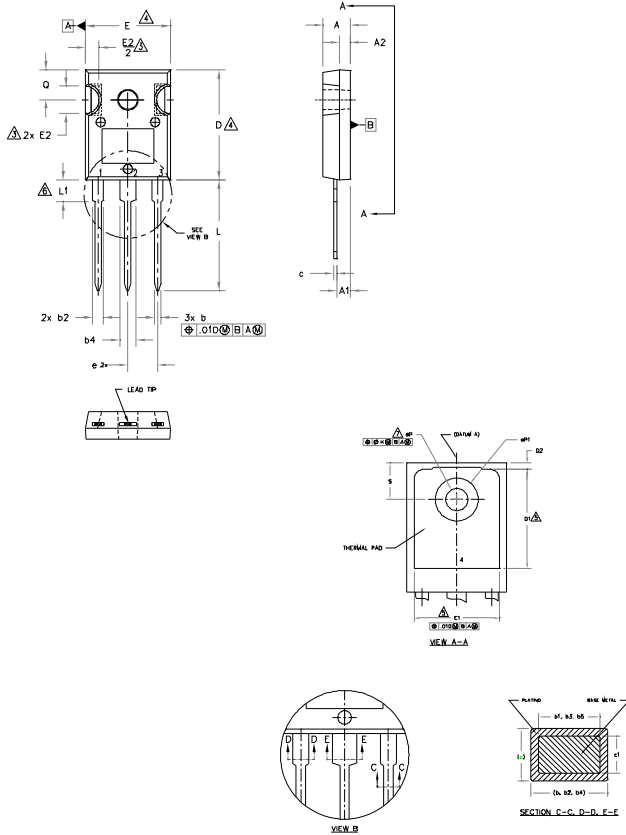

NOTES:

- DIMENSIONING AND TOLERANCING AS PER ASME Y14.5M 1994.
- DIMENSIONS ARE SHOWN IN INCHES.
- CONTOUR OF SLOT OPTIONAL.
- DIMENSION D & E DO NOT INCLUDE MOLD FLASH. MOLD FLASH SHALL NOT EXCEED .005" (0.127) PER SIDE. THESE DIMENSIONS ARE MEASURED AT THE OUTERMOST EXTREMES OF THE PLASTIC BODY.
- THERMAL PAD CONTOUR OPTIONAL WITHIN DIMENSIONS D1 & E1.
- LEAD FINISH UNCONTROLLED IN L1.
- φP TO HAVE A MAXIMUM DRAFT ANGLE OF 1.5° TO THE TOP OF THE PART WITH A MAXIMUM HOLE DIAMETER OF .154 INCH.
- OUTLINE CONFORMS TO JEDEC OUTLINE TO-247AD.

SYMBOL	DIMENSIONS				NOTES
	INCHES		MILLIMETERS		
	MIN.	MAX.	MIN.	MAX.	
A	.190	.203	4.83	5.13	
A1	.087	.102	2.21	2.59	
A2	.059	.098	1.50	2.49	
b	.039	.055	0.99	1.40	
b1	.039	.053	0.99	1.35	
b2	.065	.094	1.65	2.39	
b3	.065	.092	1.65	2.34	
b4	.102	.135	2.59	3.43	
b5	.102	.133	2.59	3.38	
c	.015	.035	0.38	0.89	
c1	.015	.033	0.38	0.84	
D	.776	.815	19.71	20.70	4
D1	.515	-	13.08	-	5
D2	.020	.053	0.51	1.35	
E	.602	.625	15.29	15.87	4
E1	.530	-	13.46	-	
E2	.178	.216	4.52	5.49	
e	.215 BSC		5.46 BSC		
eK	.010		0.25		
L	.780	.827	19.57	21.00	
L1	.146	.169	3.71	4.29	
φP	.140	.144	3.56	3.66	
φP1	-	.291	-	7.39	
φ	.209	.224	5.31	5.69	
S	.217 BSC		5.51 BSC		

LEAD ASSIGNMENTS

HEXFET

- GATE
- DRAIN
- SOURCE
- DRAIN

IGBTs, CoPACK

- GATE
- COLLECTOR
- EMITTER
- COLLECTOR

DIODES

- ANODE/OPEN
- CATHODE
- ANODE

TO-247AD Part Marking Information

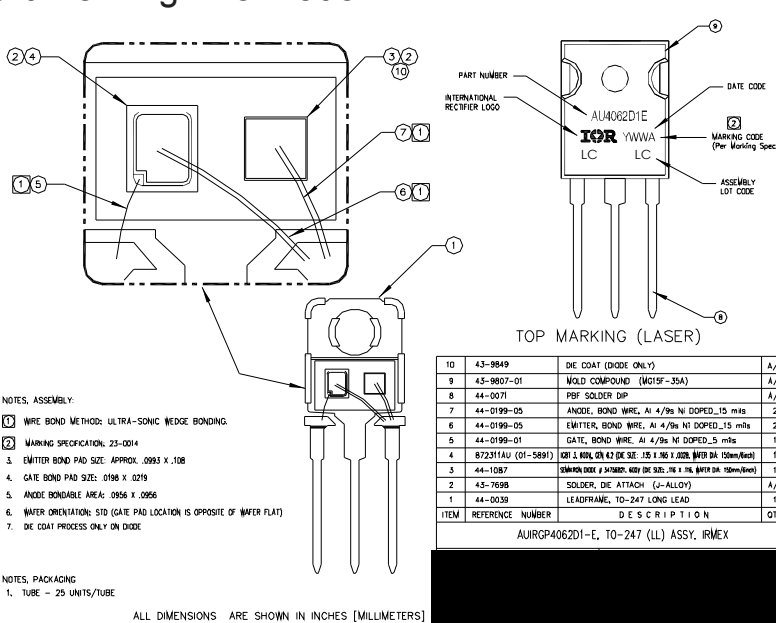

Note: For the most current drawing please refer to IR website at <http://www.irf.com/package/>

Qualification Information[†]

Qualification Level		Automotive (per AEC-Q101) ^{††}	
		Comments: This part number(s) passed Automotive qualification. IR's Industrial and Consumer qualification level is granted by extension of the higher Automotive level.	
Moisture Sensitivity Level		3L-TO-247AC	N/A
		3L-TO-247AD	
ESD	Machine Model	Class M4 (+/- 700V) (per AEC-Q101-002)	
	Human Body Model	Class H1C (+/- 2000V) (per AEC-Q101-001)	
	Charged Device Model	Class C5(+/- 2000V) (per AEC-Q101-005)	
RoHS Compliant		Yes	

[†] Qualification standards can be found at International Rectifier's web site: <http://www.irf.com/>

^{††} Highest passing voltage.

IMPORTANT NOTICE

Unless specifically designated for the automotive market, International Rectifier Corporation and its subsidiaries (IR) reserve the right to make corrections, modifications, enhancements, improvements, and other changes to its products and services at any time and to discontinue any product or services without notice. Part numbers designated with the "AU" prefix follow automotive industry and / or customer specific requirements with regards to product discontinuance and process change notification. All products are sold subject to IR's terms and conditions of sale supplied at the time of order acknowledgment.

IR warrants performance of its hardware products to the specifications applicable at the time of sale in accordance with IR's standard warranty. Testing and other quality control techniques are used to the extent IR deems necessary to support this warranty. Except where mandated by government requirements, testing of all parameters of each product is not necessarily performed.

IR assumes no liability for applications assistance or customer product design. Customers are responsible for their products and applications using IR components. To minimize the risks with customer products and applications, customers should provide adequate design and operating safeguards.

Reproduction of IR information in IR data books or data sheets is permissible only if reproduction is without alteration and is accompanied by all associated warranties, conditions, limitations, and notices. Reproduction of this information with alterations is an unfair and deceptive business practice. IR is not responsible or liable for such altered documentation. Information of third parties may be subject to additional restrictions.

Resale of IR products or serviced with statements different from or beyond the parameters stated by IR for that product or service voids all express and any implied warranties for the associated IR product or service and is an unfair and deceptive business practice. IR is not responsible or liable for any such statements.

IR products are not designed, intended, or authorized for use as components in systems intended for surgical implant into the body, or in other applications intended to support or sustain life, or in any other application in which the failure of the IR product could create a situation where personal injury or death may occur. Should Buyer purchase or use IR products for any such unintended or unauthorized application, Buyer shall indemnify and hold International Rectifier and its officers, employees, subsidiaries, affiliates, and distributors harmless against all claims, costs, damages, and expenses, and reasonable attorney fees arising out of, directly or indirectly, any claim of personal injury or death associated with such unintended or unauthorized use, even if such claim alleges that IR was negligent regarding the design or manufacture of the product.

Only products certified as military grade by the Defense Logistics Agency (DLA) of the US Department of Defense, are designed and manufactured to meet DLA military specifications required by certain military, aerospace or other applications. Buyers acknowledge and agree that any use of IR products not certified by DLA as military-grade, in applications requiring military grade products, is solely at the Buyer's own risk and that they are solely responsible for compliance with all legal and regulatory requirements in connection with such use.

IR products are neither designed nor intended for use in automotive applications or environments unless the specific IR products are designated by IR as compliant with ISO/TS 16949 requirements and bear a part number including the designation "AU". Buyers acknowledge and agree that, if they use any non-designated products in automotive applications, IR will not be responsible for any failure to meet such requirements.

For technical support, please contact IR's Technical Assistance Center

<http://www.irf.com/technical-info/>

WORLD HEADQUARTERS:

101 N. Sepulveda Blvd., El Segundo, California 90245

Tel: (310) 252-7105