

PART NAME: KNOB      SCALE: 1:1      DATE: 4/26/95      DR. BY HD

THIS DRAWING IS THE PROPERTY OF DAVIES MOLDING COMPANY, IS SUBMITTED SOLELY AS A DESIGN OR ENGINEERING PROJECT. WE ACCEPT NO RESPONSIBILITY WHATSOEVER FOR THE PRACTICAL APPLICATION OF THE PIECES MADE TO THIS DESIGN.

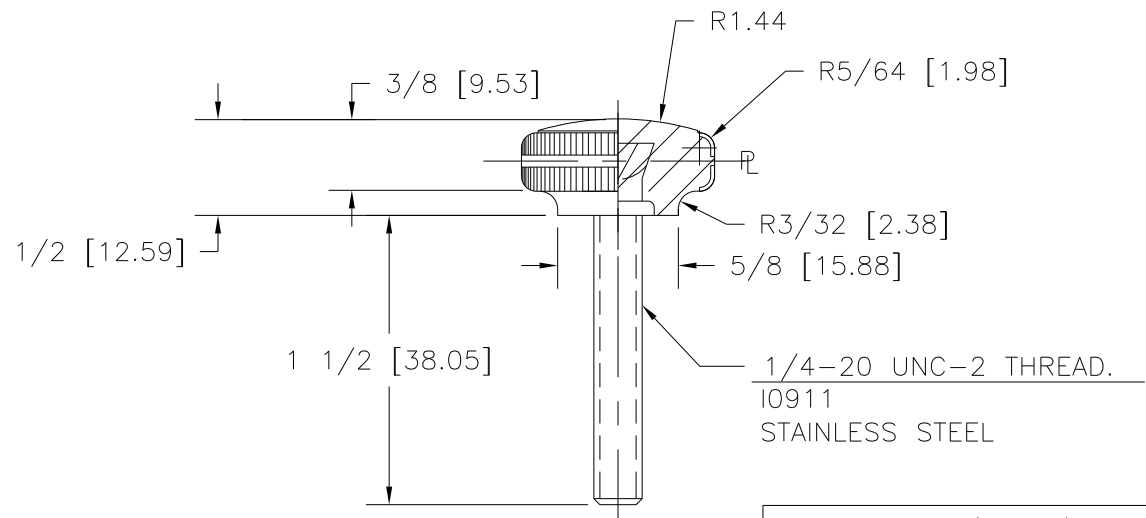

P/N	3065DJ
M NO.	1475
CAVITY	3065
PLUNGER	3065
SHIMS	1&2 (.500 THK)
SPACER	3065
PIN	2965-DX
INSERT	I0911
PLUNGER KEY	1/4x1/4x7/16
CAVITY KEY	1/4x1/4x1/2

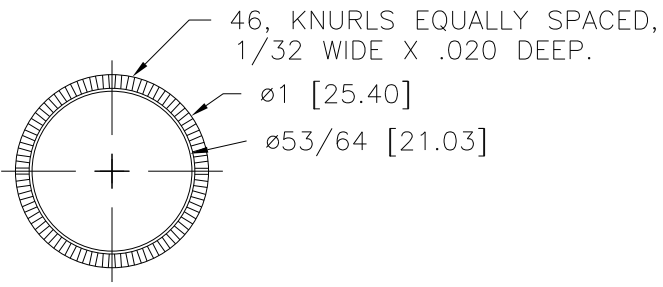

NOTE : TUBE (T0130) MUST BE INSTALLED TO ABOVE PART(S) DURING MOLDING PROCESS.

MATERIAL: G.P. PHENOLIC (B11)  
COLOR: BLACK

TOLERANCES: UNLESS OTHERWISE SPECIFIED	DO NOT SCALE DRAWING				
DECIMALS: X.XXX ± .005 X.XX ± .015	MM: X.XX ± 0.15MM X.X ± 0.4MM				
FRACTIONS ± 1/64	ANG. ± 1°	CHANGES			