

OM-0100-C7

Low Power Clock Oscillator 100.000 kHz

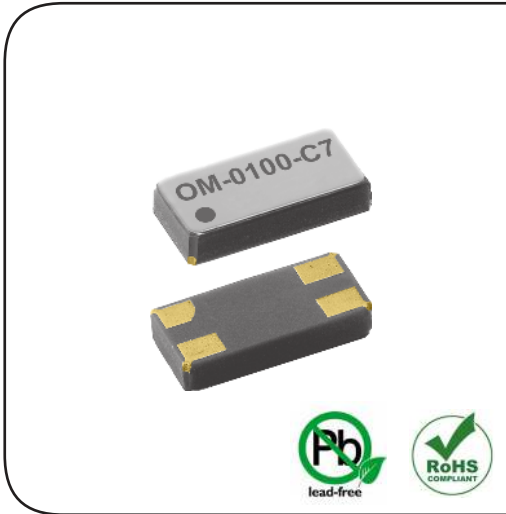

DIMENSIONS

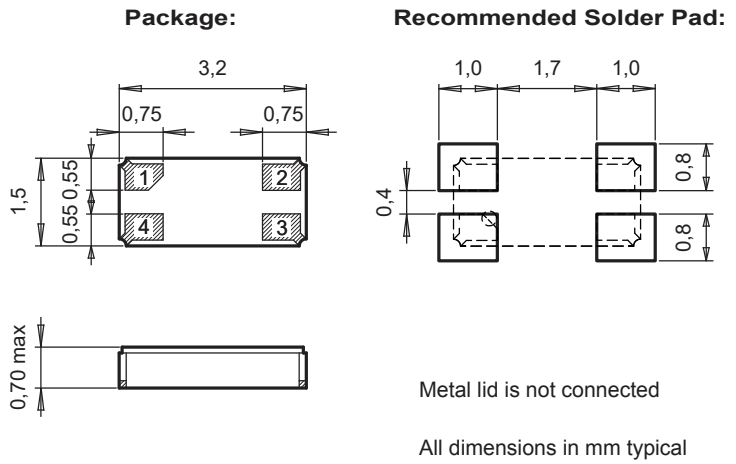

APPLICATIONS

IoT
 Metering
 Industrial
 Automotive
 Health Care
 Wearables, Portables

DESCRIPTION

The OM-0100-C7 is a Low Frequency SMD Oscillator that incorporates an integrated CMOS circuit together with an XTAL. It operates under vacuum in a hermetically sealed ceramic package with metal lid.

FEATURES

Wide supply voltage range.
 Very low power consumption.
 CLKOUT enable/disable.
 Small size, low profile, lightweight (10.6 mg).
 High shock and vibration resistant.
 100% Pb-free, RoHS-compliant.
 Automotive qualification according to AEC-Q200 available.

BLOCK DIAGRAM

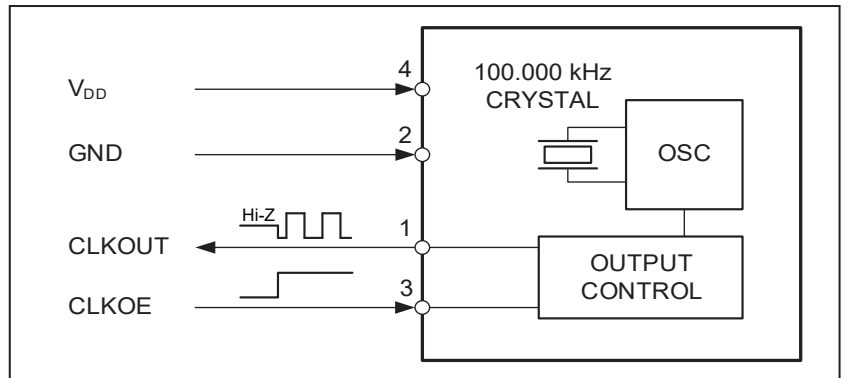

PIN CONNECTIONS TOP VIEW

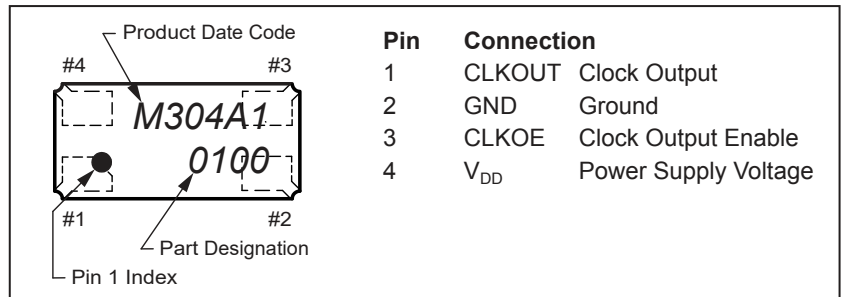

ELECTRICAL CHARACTERISTICS AT 25°C

More detailed information can be found in the Application Manual.

Output Frequency	F	100.000	kHz
Frequency tolerance	¹⁾ ΔF/F	±20	ppm
Supply voltage	V _{DD}	1.2 – 5.5	V
Current consumption (typ./max.)	²⁾ I _{DD}	0.65 / 0.85	μA
Duty cycle (min./max.)		40 / 60	%
Start up time (max.)	t _{start}	0.5	s
Voltage coefficient (max.)		±1.5	ppm/V
Aging first year max. @ 25°C	ΔF/F	±3	ppm
Turnover temperature (typ.)	T ₀	18 ±5	°C
Frequency vs. temperature	ΔF/F ₀	-0.035 ppm/°C ² (T - T ₀) ² ±10%	ppm

1) Tighter tolerances on request.

2) V_{DD} = 3.0 V, CLKOE = LOW.

ENVIRONMENTAL CHARACTERISTICS

	Conditions	Max. Dev.
Storage temperature range	-55 to +125°C	
TA Operating temperature range	-40 to +85°C	
Shock resistance	ΔF/F 5000 g, 0.3 ms, ½ sine	±5 ppm
Vibration resistance	ΔF/F 20 g / 10–2000 Hz	±5 ppm

TERMINATIONS AND PROCESSING

Package	Termination	Processing
SON-4	Au flashed pads	IPC/JEDEC J-STD-020C 260°C / 20 - 40 s

FREQUENCY TEMPERATURE CHARACTERISTICS

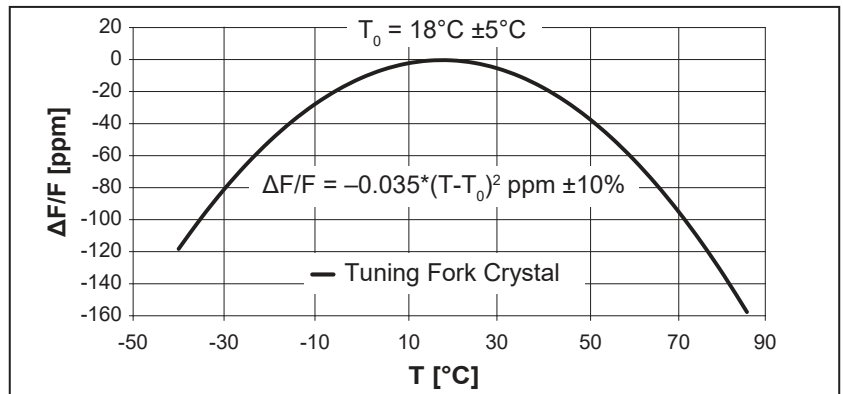

ORDERING INFORMATION

O M - 0100 - C7 ±20 ppm TA QC

Oscillator
Metal lid
Frequency
 0100 = 100.000 kHz
Package size
 C7 = 3.2 x 1.5 x 0.70 mm

Qualification
QC = Commercial Grade (Standard)
QA = Automotive Grade AEC-Q200

Temperature range
TA = -40 to +85°C (Standard)

Frequency tolerance
 ±20 ppm
 Tighter freq. tolerances on request

A unique part number will be generated for each product specification, i.e:	
20xxxx-MG01	1'000 pcs (in 12 mm tape on 7" reel)
20xxxx-MG03	3'000 pcs (in 12 mm tape on 7" reel)

All specifications subject to change without notice.



MICRO CRYSTAL SWITZERLAND

A COMPANY OF THE SWATCH GROUP

Micro Crystal AG
 Muehlestrasse 14
 CH-2540 Grenchen
 Switzerland

Phone +41 32 655 82 82
 sales@microcrystal.com
 www.microcrystal.com