

Figure 1

1. INTRODUCTION

This instruction sheet provides application instructions, maintenance, and inspection procedures for PIDG STRATO-THERM Terminal Crimping Dies 1976976-1 and 1976977-1 used in Battery Tool 1901343-[]. These dies will crimp PIDG STRATO-THERM Terminals with a wire size range of 12-10 AWG.

Basic instructions on the use of these dies, die adjustments, wire preparation, etc. are provided in Section 2, INSTRUCTIONS.

Section 3, MAINTENANCE and INSPECTION PROCEDURES enables you to establish and maintain a die certification program.

The dies are coated with oil to prevent rust and corrosion. With this oil from the dies, particularly from the crimping area. Instructions for the Battery Tool 1901343-[] are found in Instruction Sheet 408-10070.

i **NOTE**
Dimensions in this instruction sheet are in millimeters [with inches in brackets]. Figures and illustrations are for reference only and are not drawn to scale.

2. INSTRUCTIONS

2.1. Die Insertion

1. Pivot the latch arm away from the yoke to open the crimping head.

2. Loosen the set screw in the yoke.
3. Insert the shank of the nest into the yoke and tighten the set screw.
4. Extend the ram until the set screw is visible.
5. Loosen the set screw in the ram.
6. Insert the shank of the indenter into the ram and tighten the set screw.
7. Return the ram to the down position.
8. Pivot the latch arm and yoke toward each other until the locking flange secures the latch arm to the yoke.

2.2. Die Removal

1. Pivot the latch arm away from the yoke to open the head.
2. Loosen the set screw in the yoke and remove the nest.
3. Raise the ram to "full-up" position.
4. Loosen the set screw in the ram and remove the indenter.

2.3. Wire Stripping and Crimping Procedure

A. Wire Stripping

Strip the wires to the dimensions provided in Figure 2.

i **NOTE**
Refer to Paragraph 2.4 for die insulation crimp adjustment.

B. Crimping Procedure

! **DANGER**
Avoid personal injury. When operation the tool, exercise caution while holding terminals or wire near the crimping area.

1. Select the proper terminal for the wire to be crimped.
2. Place the terminal in the stationary die as shown in Figure 3.

i **NOTE**
Dies will not accommodate terminals with tongue widths exceeding 11.91 mm [.469 in.].

3. Jog the ram by pulsing the trigger until the moving die retains, but does not deform the terminal.
4. Insert a stripped wire into the terminal until the wire butts against the locator.



NOTE
Do not turn or twist the wire or terminal during insertion.

5. Hold the wire in place while activating the tool to complete the crimp.
6. The ram should automatically retract when the crimping cycle is complete. The terminal can be removed after the ram has retracted.

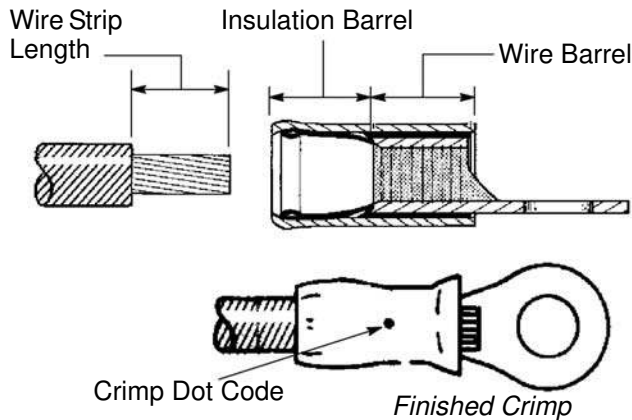

DIE PART NUMBER	WIRE SIZE (AWG)	COLOR AND DOT CODE	WIRE STRIP LENGTH	
			Min.	Max.
1976977-1	12	1 Dot (White)	5.56	6.35
1976976-1	10	1 Dot (Black)	[.219]	[.250]

Figure 2

2.4. Insulation Crimp Adjustment

1. The insulation crimping section of the moving die has three crimp positions: 1-Tight, 2-Medium, and 3-Loose.
2. Turn both insulation crimp adjustment spacers so that they fit into the notch in the side of the die. See Figure 1. This is the No. 3 or loose position. *(The insulation crimper screw must be loosened to make this adjustment.)*
3. Turn the insulation crimper screw enough to hold the die firmly in place. The insulation crimper screw will be tightened after completing steps 5 and 6.
4. Insert the unstripped wire into ONLY the insulation barrel position of the terminal.
5. Make a test crimp (refer to Paragraph 2.3.B for crimping procedure). Close the die on the terminal and hold the die in the bottomed position. Tighten the insulation crimper screw while the dies are bottomed, then complete the crimping cycle.
6. Remove the terminal from the dies, and check the insulation grip as follows: bend the wire back and force once. The terminal sleeve should retain the grip on the wire insulation.

7. If the wire pulls out, use the following procedure to set the insulation crimp adjustment to the next tighter position.
 - a. First, loosen the insulation crimper screw.
 - b. Then, turn the lower insulation adjustment spacer 905 so that it fits between the insulation crimper and the die. The No. 2 will appear on the corner of the spacer.
 - c. Repeat the test crimp, and adjust the die as necessary until the desired insulation grip is obtained.
8. With both adjustment spacers placed between the die and the die holder, the die is set in its tightest insulation crimping position. The No. 1 will appear on the corner of the top spacer.

2.5. Color and Dot Code

Note that the dies and terminals are color-coded according to wire size for easy identification. See Figure 2. When the terminals are properly crimped in the correct dies, 1 dot or 2 dots (depending on wire size), will appear embossed on the top and bottom of the terminal. See Figure 3.

NOTE: To locate PIDG STRATO-THERM Terminals, pull locator down slightly.

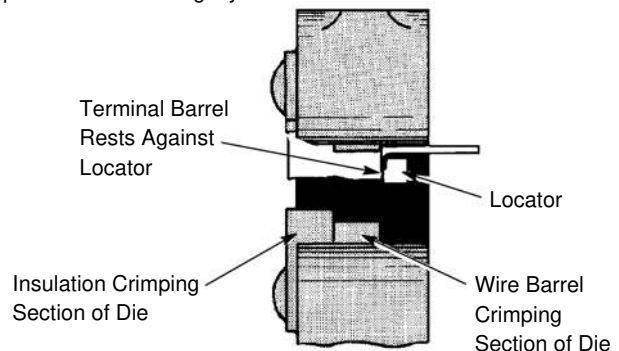

Figure 3



CAUTION
Damaged product should not be used. If a damaged product is evident, it should be cut from the wire and replaced with a new one. Do NOT reterminate terminals.

3. MAINTENANCE AND INSPECTION PROCEDURE

TE Connectivity recommends that a maintenance inspection program be performed periodically. This is necessary to ensure that continued use of the dies will result in the same dependable and uniform terminations for which the dies were designed.

TE recommends an initial frequency of inspection of once a month. This frequency may be adjusted to suit requirements through experience. The frequency of an inspection is dependent upon:

- The care, amount of use, and handling of the dies
- The type and size of the products applied
- The degree of operator skill
- The presence of abnormal amounts of dust and dirt
- User-established standards

With proper maintenance and inspection, these dies will give years of satisfactory service.

All TE dies are thoroughly inspected before being shipped from the factory, however, since there is a possibility of die damage during shipment, TE recommends that new dies be inspected in accordance with Section 3 when received in your plant.

3.1. Cleaning

Do not allow deposits of dirt, grease, and foreign matter to accumulate in the die closure area and on the bottoming surfaces of the dies. These deposits may prevent the dies from bottoming fully and may also cause excessive wear in the die closure surfaces, thereby affecting the quality of the crimp. The dies should be wiped clean frequently with a clean, soft cloth.

3.2. Visual Inspection

Visually inspect the die closure surfaces for broken, chipped, or pitted conditions. Although dies may gage within permissible limits, worn or damaged die closure surfaces are objectionable and can affect the quality of the crimp. Examples of possible damaged die surfaces are shown in Figure 4.

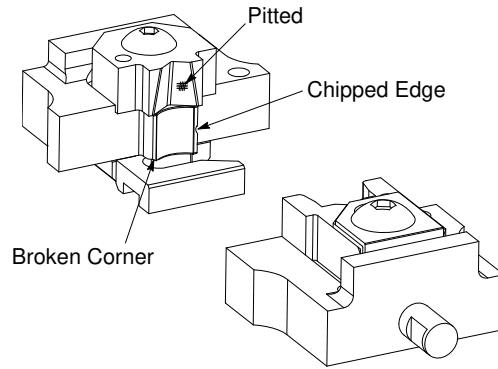

Figure 4

3.3. Die Closure Inspection

Every TE die set is inspected and tested for proper die closure before being shipped from the factory. An inspection should, however, be performed periodically to measure the die closure.

The die closure inspection is accomplished using the GO, NO-GO plug gages. A suggested plug gage design of the GO, NO-GO dimensions of the plug gage members are provided in Figure 5.

The following procedure is recommended for measuring the die closures:

1. Remove traces of oil or dirt from the die crimping areas, and plug gage members.
2. Turn both insulation adjustment spacers of the moving die so that they fit into the notch in the side of the die. See Figure 1. The die is now set in the No. 3 or loose position. This will provide access to the wire barrel dies for plug gaging.

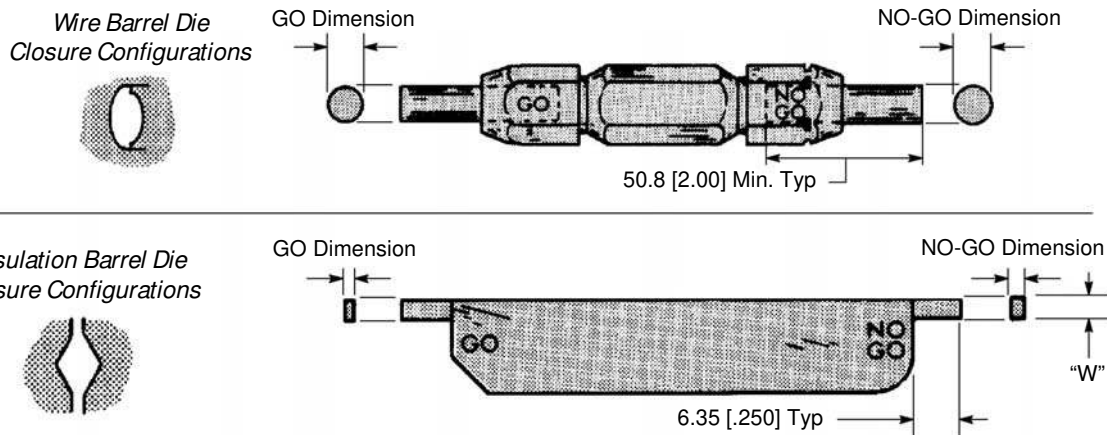

DIE SET	WIRE BARREL CRIMP CHAMBER		INSULATION BARREL CRIMP CHAMBER		
	GO	NO-GO	GO	NO-GO	WIDTH (W)
1976977-1	3.683-3.691 [.1450-.1453]	3.782-3.785 [.1489-.1490]	1.067-1.074 [.0420-.0423]	1.471-1.473 [.0579-.0580]	6.63 [.261]
1976976-1	4.775-4.783 [.1880-.1883]	4.874-4.877 [.1919-.1920]	1.676-1.684 [.0660-.0663]	2.080-2.083 [.0819-.0820]	8.43 [.332]

Figure 5

3. Insert both dies in the tool die holders.
4. Some dies need to be removed from the hand tool to gage the wire barrel dies. The position of the locator and the insulation die prevent gaging the wire barrel in the tool. Remove the complete die assembly and rotate the locator 180 degrees. This will allow access to the wire barrel die. The complete die can then be placed in a vise with light pressure for gaging.
5. With the wire barrel dies bottomed, check the wire barrel crimp die closure using the proper plug gage. Hold the gage in a straight alignment with the die closure and carefully try to insert, without forcing the GO member, and then the NO-GO member. See Figure 6, Detail A. The GO member must pass completely through the insulation and wire barrel crimp die closures.
6. The NO-GO member may enter partially, but must not pass completely through the wire barrel crimp die closure. See Figure 6, Detail A.
7. Remove the moving die from the tool die holder.
8. Reposition the insulation adjustment spacers in the No. 1 position. Refer to Paragraph 2.4 for insulation crimp position adjustment procedures.

9. Insert the moving die into the tool die holder.
10. With the wire barrel dies bottomed, check the insulation crimp die closure using the proper plug gage in the same manner as steps 6 and 7. See Figure 6, Detail B.
11. If both the wire barrel and insulation die closures meet the GO, NO-GO gage conditions, the dies may be considered dimensionally correct.
12. If you find that the crimp die closures do not conform with the GO, NO-GO gage conditions, contact your local TE Representative.

4. REPLACEMENT PARTS

A complete inventory of customer-replaceable parts for each die set assembly should be stocked and controlled to prevent lost time when replacement of parts is necessary. See Figure 7. Order replacement parts through your local TE Representative, or call 1-800-526-5142, or send a facsimile of your purchase order to 1-717-986-7605, or write to:

**CUSTOMER SERVICE (038-035)
 TYCO ELECTRONICS CORPORATION
 PO BOX 3608
 HARRISBURG PA 17105-3608**

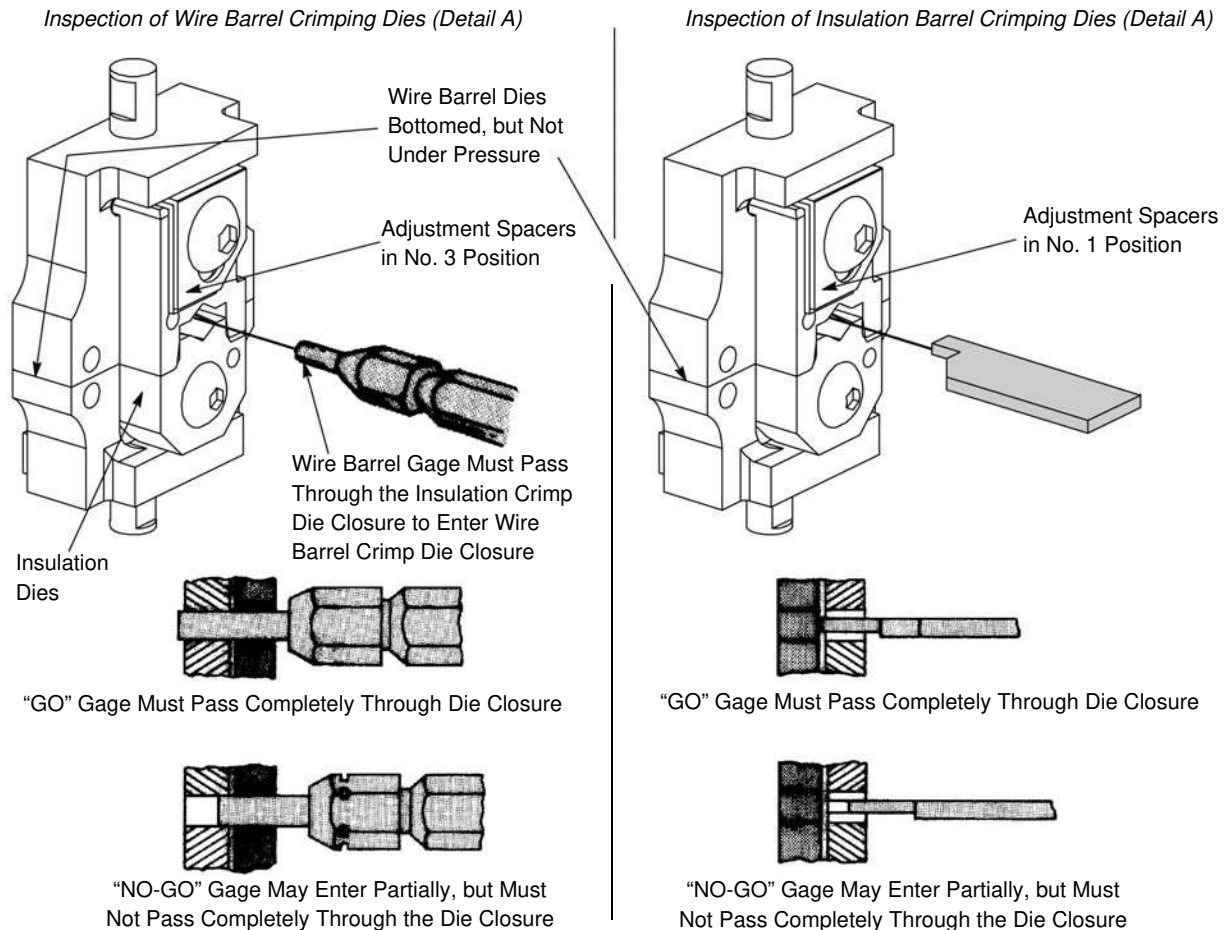
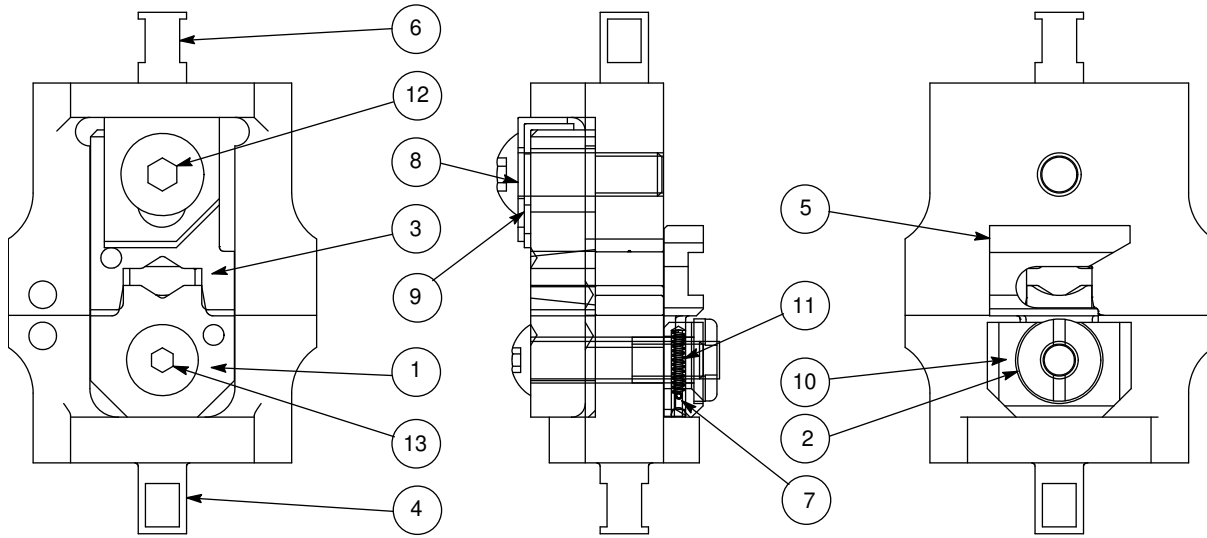

Figure 6

Tools and dies may also be returned to evaluation and repair. For repair service, contact a TE Representative at 1-800-526-5136.

5. REVISION SUMMARY

- Changed die set part number in table in Figure 7



ITEM NO.	DESCRIPTION	QTY PER DIE SET	DIE SET NUMBERS	
			1976977-1	1976976-1
1	ANVIL, Insulation	1	1-45932-8	3-45932-1
2	BARREL NUT	1	2031532-1	2031532-1
3	INDENTER, Insulation	1	2-45931-3	2-45931-9
4	INDENTER, STRATO-THERM	1	1976979-2	1976979-1
5	LOCATOR	1	576771-5	576771-5
6	NEST, STRATO-THERM	1	1976978-2	1976978-1
7	PIN, Spring	2	21949-1	21949-1
8	SPACER, Ins	1	306027-6	1-306027-0
9	SPACER, Ins	1	306027-7	306027-9
10	SPACER, Locator	1	2-305832-9	2-305832-9
11	SPRING	2	7-59683-4	7-59683-4
12	SCREW, 10-32	1	2-21002-6	2-21002-8
13	SCREW, 8-32	1	2-21002-2	2-21002-4

Figure 7