



## NB IoT – Cat-M1 Operated IP68 Low Power Floating Level Transmitter for Water Resource Management

- Compatible with most standard communication Protocols (UDP, LwM2M, MQTT, NIDD, etc.)
- Wide range of industrial applications
- High accuracy and Ultra-low power
- Designed to meet outdoor applications
- Long-term durable performance in harsh environment
- Designed for Water Resource Level and Volume Measurement



## TECHNICAL SPECIFICATION

### Sensor

• Range:	1, 2, 5, 10 (or other ranges up to 200)	m H2O
• Accuracy: (combined linearity, hysteresis, repeatability)	±0.25 (typ.)	%Span
• Resolution:	±0.01	%Span
• Pressure reference:	Sealed Gauge (with Built-in Atmospheric Pressure Sensor and floating housing)	
• Temperature Coefficient of Zero:	≤±0.03	%FS/°C
• Temperature Coefficient of Span:	≤±0.03	%FS/°C
• Long term stability (1 year):	≤ 0.2	%Span
• Overload Protection:	150	%FS
• Load Cycles (Zero to Full Scale):	10+	Million
• Storage / Operation Temperature:	-20 ~ +85	°C
• Compensated temperature:	0 ~ 60	°C

### Power

• Power Supply:	Built-in Replaceable Lithium Battery, External Power (option)	
• Rated Voltage	3.6	V
• Battery Lifetime:	50,000+ Readings and 10,000+ Transmission (With UDP protocol/ More than 10 years for most applications)	

### Physical Specification

• Materials:	O-rings: Viton, Sensor Head: SS304, Diaphragm: SS316, Oil: Silicon, Enclosure: POM and Compressed Plastic	
• Process Connection:	No Process Connection (or on request)	
• Weight:	~2,500 (for 10m range)	g
• Protection Rate:	IP68 and UV protected enclosure	

### Communication

• SIM Card Type	4FF Nano-SIM, from any Network Provider	
• Firmware Update:	Over The Air, Locally via wireless connectivity	
• Sampling Period:	Configurable via downlink (default 4 hours)	
• Power Consumption:	Power Saving: < 5uA, Transmission: < 220mA	

• Communication Standards	Cat-NB1 (NB-IoT) Cat-M1 (option of back support by GPRS)
• Communication Bands	B1/B2/B3/B4/B5/B8/B12/B13/B18/B19/B20/B26/B28 and B39
• Data Rates:	Cat-M1: 375Kbps (DL)/375Kbps (UL) NB-IoT: 32Kbps (DL)/70Kbps (UL)
• TX Power:	23dBm
• Min Receiver Sensitivity:	Cat-M1: -107dBm NB-IoT: -113dBm
• Antenna:	Internal (Default)/ External (customised options available)
• Optional Features:	<ul style="list-style-type: none"> <li>• Attach without PDN (Packet Data Network)</li> <li>• Support for IPV6</li> <li>• SMS communication</li> <li>• Mobility support (Cat-M1 only)</li> </ul>

## NETWORK CONNECTION AND VISUALISATION

### Network Integration

Pre-configured or configurable to all main narrow band networks (3, A1, AT&T, China Mobile, DU, Etisalat, KPN, M1 Singapore, Optus, Orange, Proximus, Spark, Sprint, Swisscom, Telefonica, Telstra, T-Mobile, Verizon, Vodafone, 1NCE, Emnify and any other network)

### Visualisation and Data Management

Ellenex white label microservice platform and Integratable to all main IIoT platforms directly or through the API(AWS, Azure, PTC ThingWorx, Bosch IoT, Cisco Jasper & Kinetic, Sierra Numerex, MathWorks ThingSpeak, GE Digital Predix, LandisGyr, Siemens MindSphere, Cumulocity, myDevices, Ubidots, TagoIO, AllThingsTalk Maker, HPE IoT and any other major IoT platform).

### Ellenex Platform Main Features

- Volume calculation based on the land topography formula
- Encrypted ultra-low power communication protocol
- Integration APIs for enterprise systems
- Multi-tenant role-based access control
- Data export and import
- White-label platform for enterprise runs on private account
- Variable alarm setting for high and low thresholds and multi-channel alerting
- Sampling and transmission interval configuration
- Transmission condition configuration
- Other configurations and customisation available on request



Encrypted & ultra-low power



Integratable



Dynamic alerting



Multi-tenant



Scalable



Composable & API first

## MODEL GUIDE

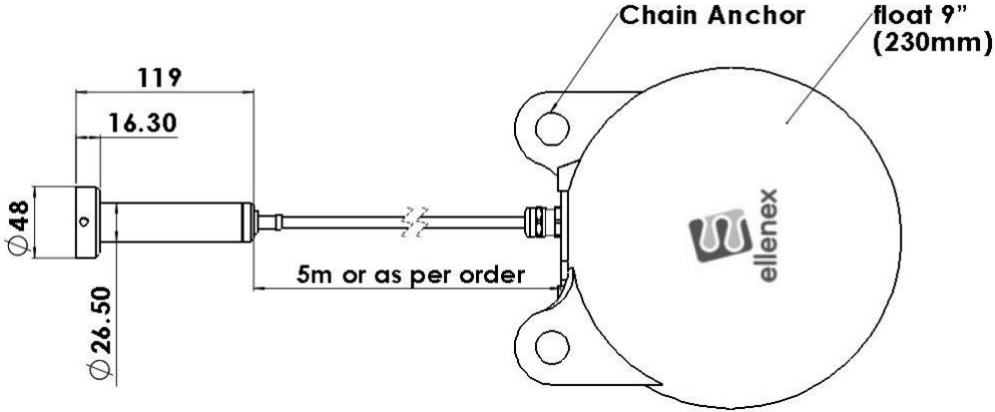
Model	
	 <p style="text-align: center;">PLV2 dimensions</p>

## INDUSTRIES



Water & Wastewater



Agriculture & Farming



Environmental Monitoring



Marine & Oceanography



Mining & Construction



Water Delivery

## APPLICATIONS

- Water Resources Level
- Dam Level
- Water Supply
- Lake Level
- Hydrology Research
- Bush Fire Management

## ORDERING CODE

PLV3-N									
Communication Type									
B: NB-IoT					C: Cat-M1				
Measurement Range									
1, 3, 10, 20, 50, 100, 200m H <sub>2</sub> O (or any other non-standard range)									
Sensor Head Material									
S: SS304 or SS316L			H: Hastelloy			Others			
Cable Material									
U: Polyurethane					Others				
Cable Length									
S: same as measurement range or 1m extra					Others				
Enclosure									
S: Standard					Others				
Device Activation									
X: No switch (always on)					Other (by request)				
Antenna									
I: Internal					E: External				
Options									
(On request) <sup>1</sup>									
PLV3-N	B	10m	S	U	S	S	X	I	

### Sample Product Code:

- **PLV3-N-B-10m-S-U-S-S-X-I**

IP68 Level sensor with floating housing operated on NB-IoT, measurement range of 10m H<sub>2</sub>O, with stainless steel sensor head and Polyurethane cable, standard cable length and enclosure, activated in the factory and equipped with internal antenna.