

Rev	AWO #	Description	Date	Appr
-		RELEASED	3/7/19	

APPROVED: \_\_\_\_\_  
 DATE: \_\_\_\_\_ TITLE: \_\_\_\_\_

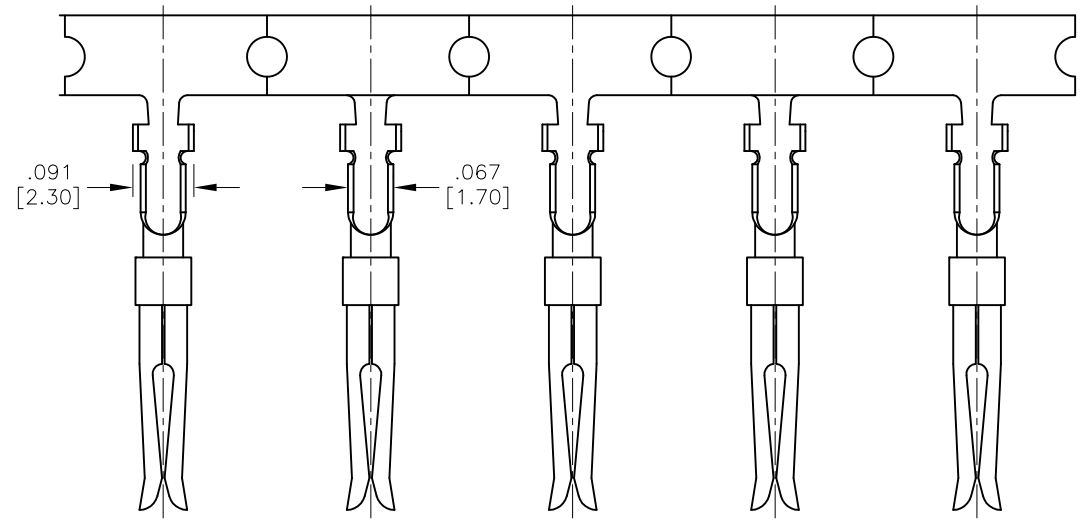

SPECIFICATIONS:  
 Material:  
 Contact: Phosphor Bronze  
 Plating:  
 Gold flash over Nickel underplate overall  
 Mechanical:  
 Recommended wire range: 24-28 AWG  
 Packaging:  
 R = Tape and Reel  
 Environmental:  
 Lead free, RoHS compliant

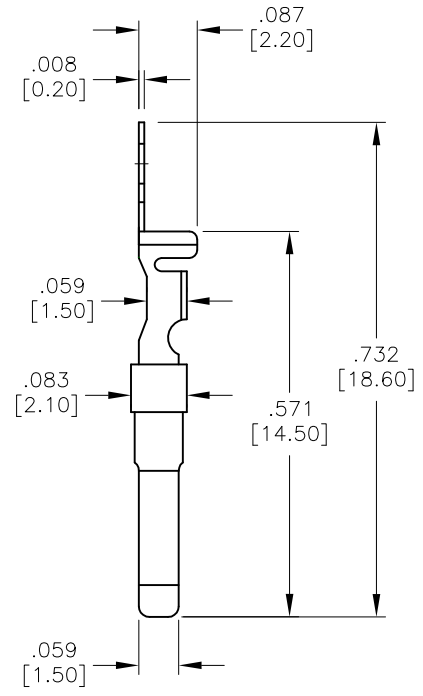

UNLESS OTHERWISE SPECIFIED ALL DIMENSIONS ARE INCHES [MM] TOLERANCES: EXCEPT AS NOTED			
INCHES		HOLES	
.X	± .10	Ø.X	± .10
.XX	± .020	Ø.XX	± .015
.XXX	± .015	Ø.XXX	± .010
APPROVALS		DATE	
DRAWN	AY	3/7/19	
CHECKED	CK	3/7/19	
APPROVED			



909 Rahway Avenue,  
 Union, NJ 07083  
 Phone: 908-687-5000  
 Fax: 908-687-5710

TITLE D-SUB SOCKET CONTACT, 24-28 AWG GOLD FLASH PLATED			
SIZE X	PART NO. DCS-01A-R	REV. -	
REF: S00298T	SCALE: NTS	SHEET 1 OF 1	