

The SwitchTrick
Breadboard-Compatible Voltage-Selectable Power Supply

FEATURES

- ◆ 1A buck (step-down) converter
- ◆ Output voltage selectable by jumper between: 1.8V, 2.5V, 3.0V, 3.3V, 3.7V, 4.2V, 5.0V, 6.0V, and a resistor-adjustable voltage
- ◆ Input voltage from 3-17V
- ◆ Diode-protected inputs include barrel jack, JST PH-2 battery header, USB, or alligator clips into plated holes
- ◆ Diodes can be bypassed with jumpers if the diode Vf drop is undesirable
- ◆ Plugs into breadboard power rails with included headers, board can be supported off breadboard with included standoffs
- ◆ EN and PGOOD broken out to breadboard-compatible holes
- ◆ ON/OFF switch enables/disables with LED for visual feedback of output presence
- ◆ Based off the Texas Instruments TPS62106 chip

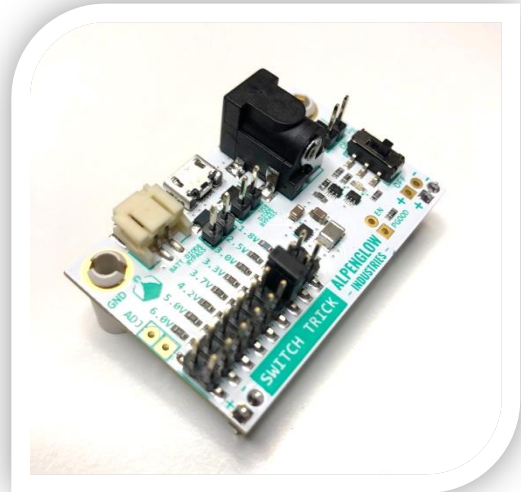

APPLICATIONS

- ◆ Breadboarding
- ◆ Low voltage processors (1.8V, 2.5V)
- ◆ 3.0 and 3.3V processors
- ◆ Simulating Li-Ion battery voltages at full, nominal, and low charge states (4.2V, 3.7V, 3.0V), from a 5V USB supply
- ◆ Servo driving (6.0V, 1A) from a 12V input

DESCRIPTION

Meet breadboard's hottest new power supply, the SwitchTrick! It's got EVERYTHING: a barrel jack, USB, 8 selectable output voltages, one adjustable voltage, and even an ON/OFF switch. It finally answers the question: whiiiiiiiiich?



ELECTRICAL CHARACTERISTICS

Symbol	Parameter	Typical Value	Units
Vin	Input Voltage	3 – 17	V
Vout (+)	Output Voltage <i>(Note 1)</i>	1.0 – 6.0	V
Iout	Output Current	1.0	A
EN	Enable <i>(Note 2)</i> (input)	0 = Disabled 0.6V – Vin = Enabled	V
PGOOD	Power Good (output)	0 = Bad Vout = Good	V
Fsw	Switching Frequency	2.25	MHz

Note 1: The SwitchTrick may be adjusted down to 0.9V if an on-board resistor is replaced, see “Output Voltage” below.

Note 2: This pin has internal connections and must not exceed Vin, for proper use see “Enable” below

For more detailed characteristics, please refer to the TPS62160 datasheet.

PROTECTIONS

- ◆ Undervoltage lockout
- ◆ Over current
- ◆ Short circuit
- ◆ Over temperature

WHAT’S WITH THE NAME?

It’s a tricked-out switching power supply. And I like snowboarding.

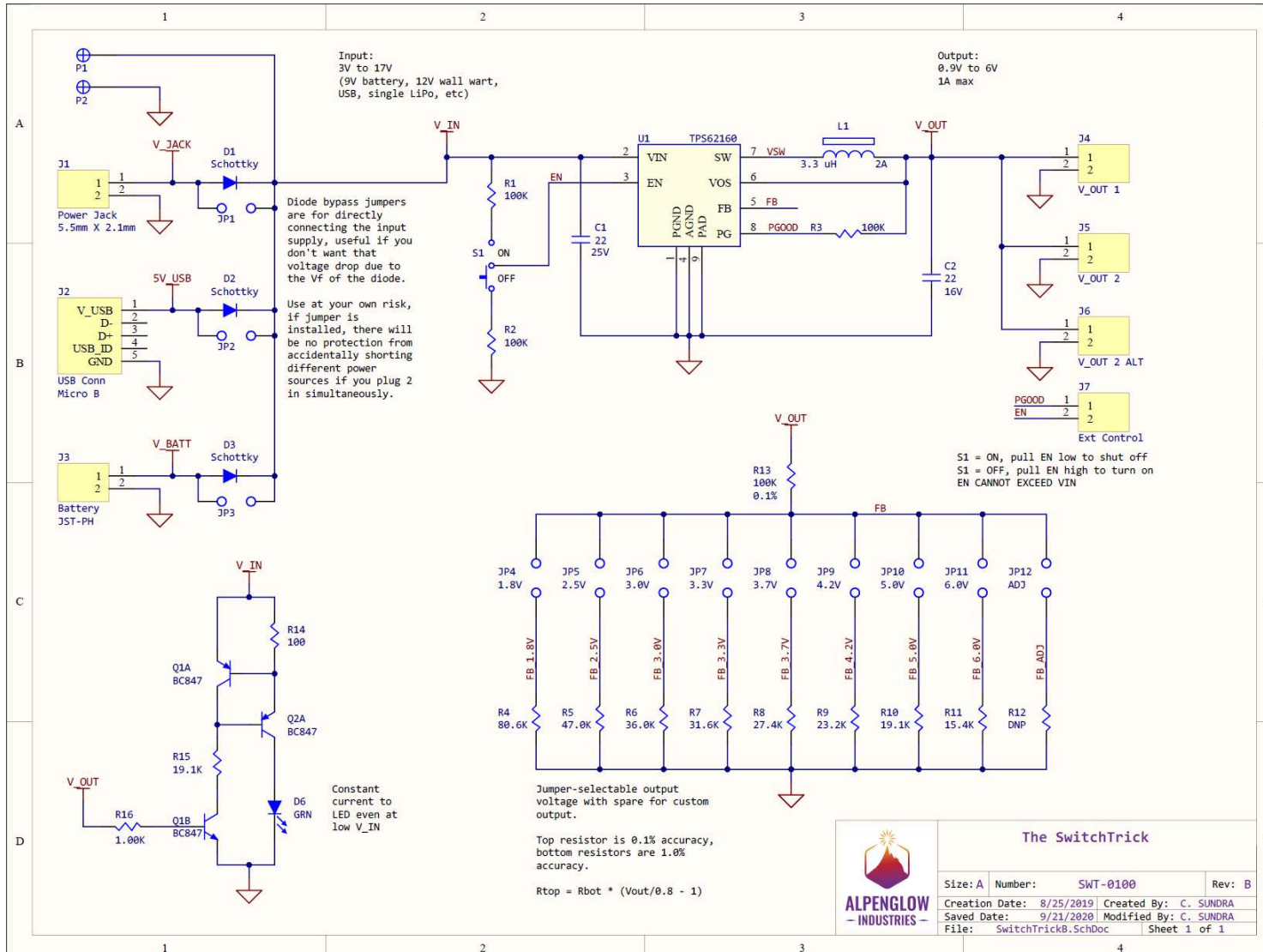
SCHEMATIC

INPUT VOLTAGE

The SwitchTrick utilizes a buck or step-down topology, meaning the input voltage must always be higher than the output voltage. The equation for this relationship is:

$$V_{in(min)} = V_{out(min)} + I_{out}(R_{DS(on)} + R_L)$$

where

$R_{DS(on)} = 0.430$ ohms (rough estimate over input voltage range)

$R_L = 0.065$ ohms

The minimum input voltages for each jumper-selectable output voltage are:

Jumper-Selectable Vout	Minimum Vin @ 250mA	Minimum Vin @ 500mA	Minimum Vin @ 1A
1.8V	1.93V	2.05V	2.3V
2.5V	2.63V	2.75V	3.0V
3.0V	3.13V	3.25V	3.5V
3.3V	3.43V	3.55V	3.8V
3.7V	3.83V	3.95V	4.2V
4.2V	4.33V	4.45V	4.7V
5.0V	5.13V	5.25V	5.5V
6.0V	6.13V	6.25V	6.5V

OUTPUT VOLTAGE

The ADJ holes are for you to create your own custom voltage by soldering in a resistor. Find the value of Rbottom to insert for your desired output voltage using:

$$R_{bottom} = \frac{R_{top}}{\frac{V_{out}}{0.8} - 1}$$

where $R_{top} = 100k$.

Note that Rbottom should not exceed 400k, which gives a minimum output voltage of 1.0V with Rtop at the default 100k. If you would like to adjust the SwitchTrick to the minimum 0.9V output that the TPS62160 is capable of, you'll need to also replace Rtop (resistor on the right side of the header, and I hope your SMT skills are good).



ENABLE

Note in the schematic that the EN pin is either pulled high or low, depending on where the ON/OFF switch is set. If you'd like to use a processor to control this pin, first determine which your default state is (ON or OFF), and set the switch accordingly. Note that voltage on this pin cannot exceed V_{in} ! For more info, see the TPS62160 datasheet.

POWER GOOD

This is an open-drain output of the TPS62160, meaning it's either disconnected inside the chip, or pulled to GND inside the chip. When the output voltage has not settled to the setpoint (power is not good), PGOOD is pulled to GND. When the output voltage is 90-95% of the set voltage, it's "open-drain" (essentially disconnected inside the TPS62160) and R3 on the SwitchTrick schematic pulls it up to the output voltage. You can daisy-chain supplies and do power-up sequencing by connecting the PGOOD output of the first supply to the EN of the second. But be sure to keep in the mind the EN voltage limit.

THE SHENANIGANS BY THE LED

Turns out it's not a trivial task to turn on a 2V V_f LED with a 1.8V output. It took 4 electrical engineers a chain of 57 emails to figure out which circuit to use, and of course it was the old analog-genius guy that came up with it. Thanks, Tom! So yes, all that business is just to have a nice green LED light up with almost constant brightness no matter what your input or output voltage is.

YOU MAY ALSO LIKE

RUL-0001
What the SOT?!
Transistor Footprint PCB Ruler

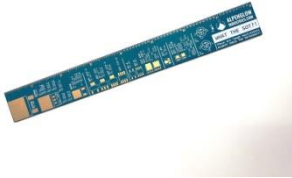

RUL-0002
For the Love of SOD
Diode Footprint PCB Ruler



CONNECT WITH US!

We love to see what you do with our products!
Tag us in your posts and use #frivolouscircuits or
#alpenglowindustries.

Instagram: @frivolous.circuits
YouTube: Alpenglow Industries
Email: info@alpenglowindustries.com