

REVISIONS				
P	LTN	DESCRIPTION	DATE	APPD
B		RELEASED PER ECO 19-008968	8-22-19	CT FB

- ⚠ PINS SHOWN IN AS-SHIPPED STATE. PINS TO BE PRESSED FLUSH TO TOP OF MODULE FLANGE BY CUSTOMER DURING ASSEMBLY PROCESS.
- ⚠ SEE VITA 67 SPECIFICATIONS FOR CONNECTOR LOCATION ON DAUGHTERCARD PCB. REFERENCE: DIM [X] FOR THE DAUGHTERCARD CONNECTOR LOCATION IS 6.76[.266] LESS THAN DIM [X] FOR THE BACKPLANE CONNECTOR LOCATION.
- ⚠ PRELIMINARY-NOT RELEASED FOR PRODUCTION

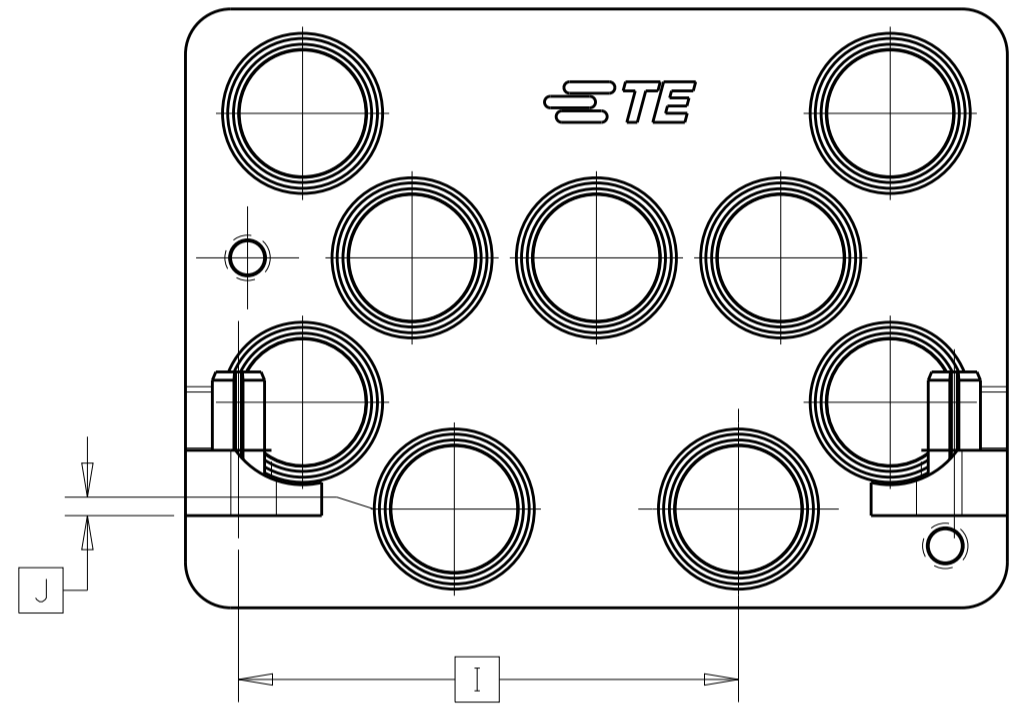

HOLE CHART			
HOLE ID	[I]	[J]	
A1	16.536 [.6510]	0.216 [.0085]	
A2	7.137 [.2810]	0.216 [.0085]	
B1	21.552 [.8485]	3.746 [.1475]	
B2	2.120 [.0835]	3.746 [.1475]	
C1	17.932 [.7060]	8.521 [.3355]	
C2	11.836 [.4660]	8.521 [.3355]	
C3	5.740 [.2260]	8.521 [.3355]	
D1	21.552 [.8485]	13.297 [.5235]	
D2	2.120 [.0835]	13.297 [.5235]	

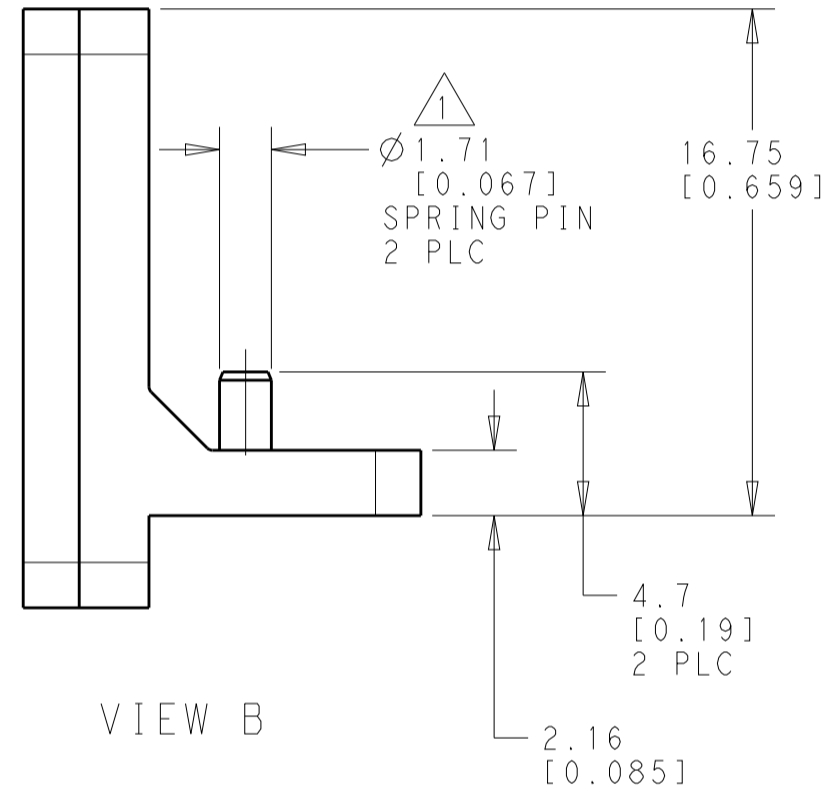
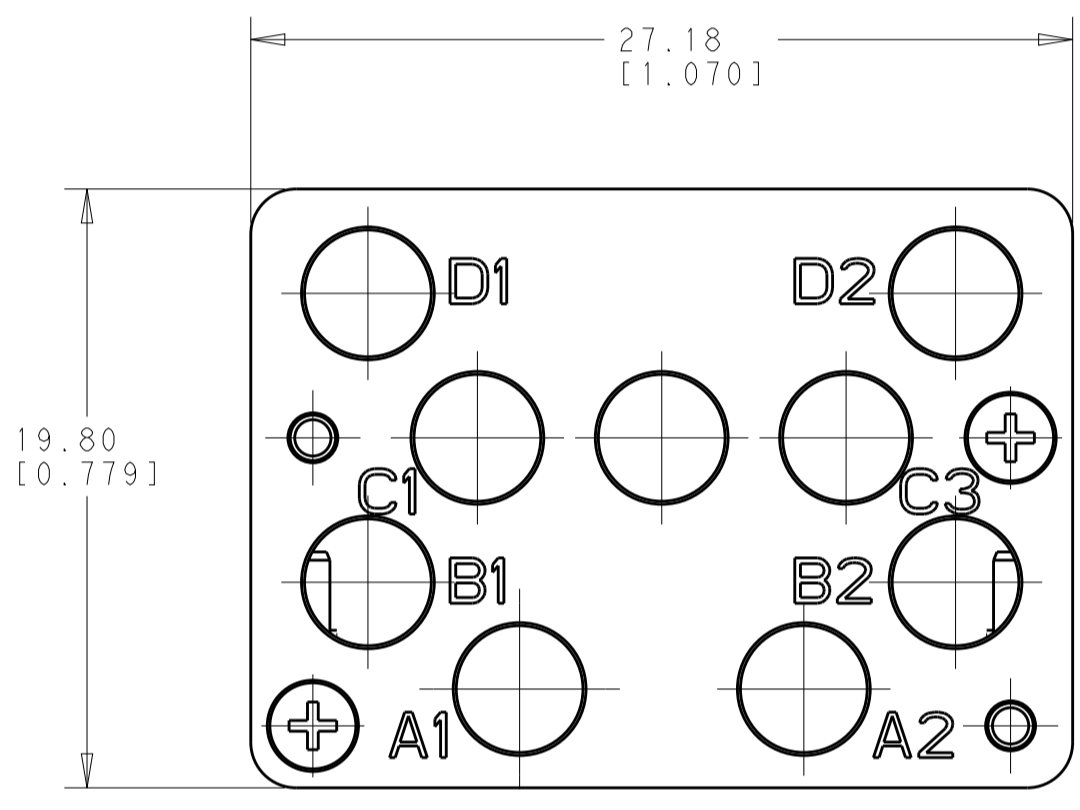
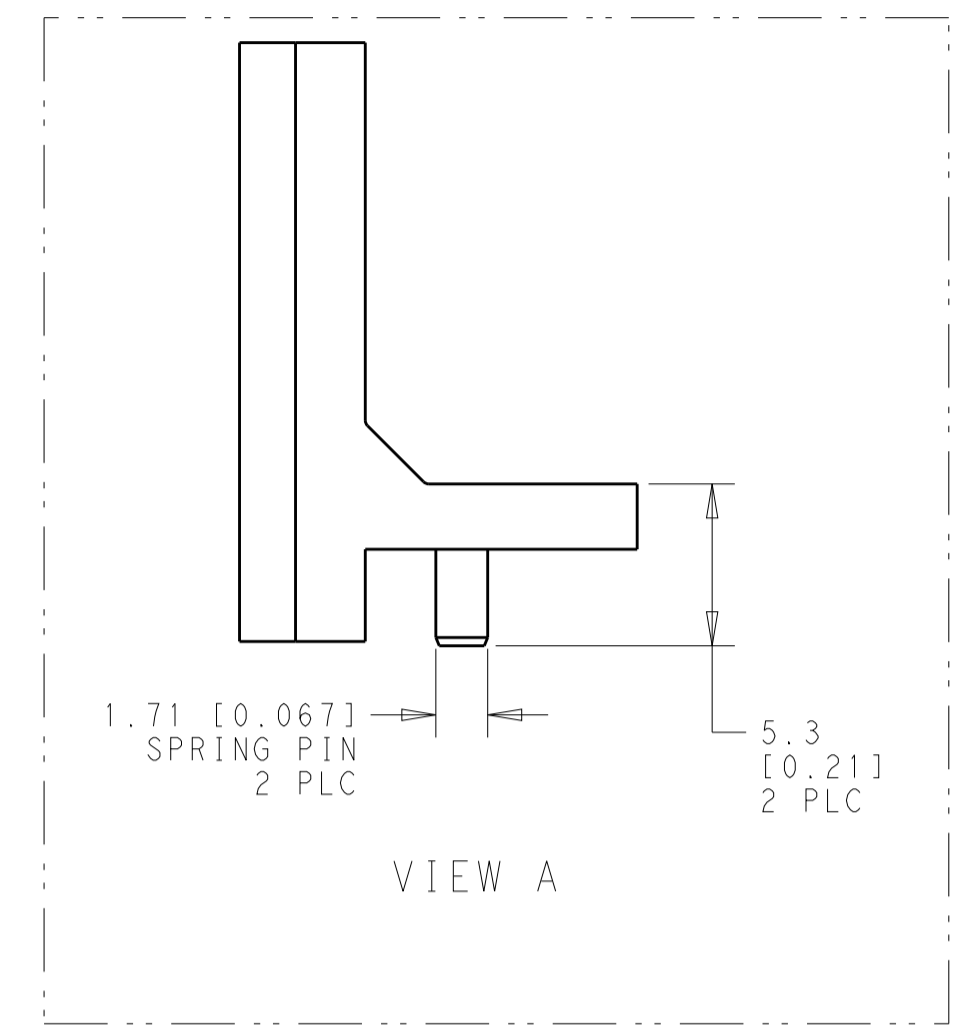
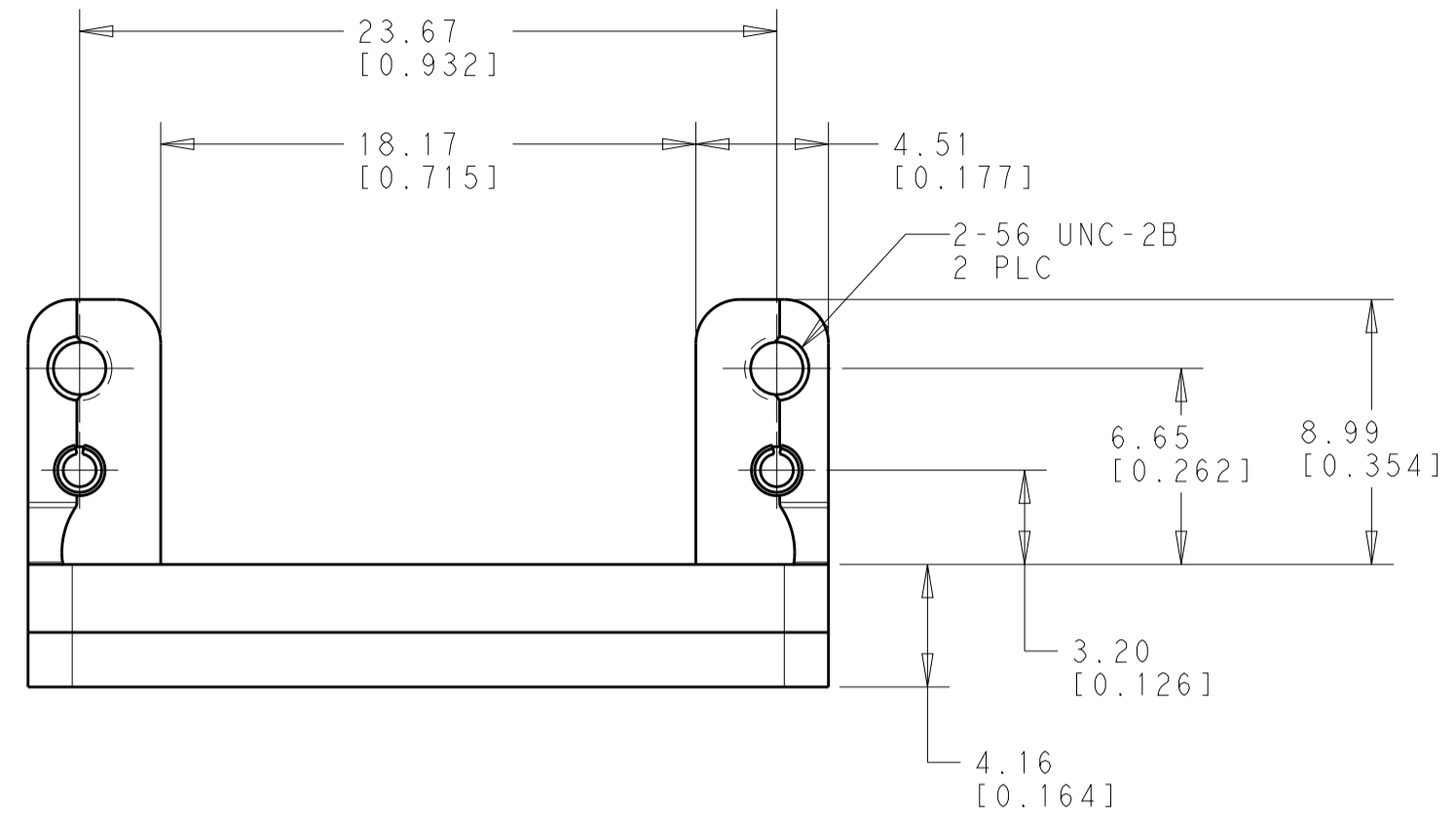
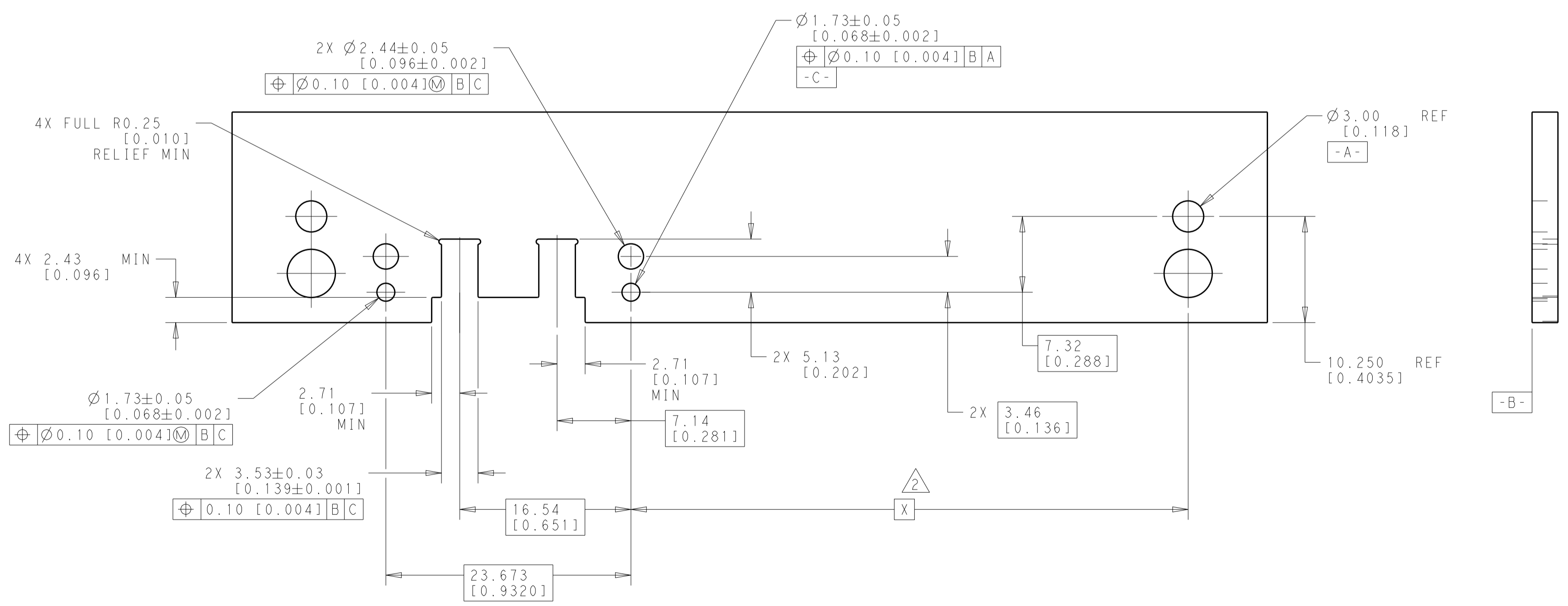

TE PART NO.	COMPONENT	MATERIAL	FINISH	VIEW
2332834-4	HOUSING	ALUMINUM ALLOY 7075-T651	TRIVALENT CHROMATE CONVERSION COATING, PER MIL-DTL-5541F, CLASS 1A, TYPE II	B
	SPRING PIN	NICKEL STAINLESS STEEL	PASSIVATED	
2332834-3	HOUSING	ALUMINUM ALLOY 7075-T651	TRIVALENT CHROMATE CONVERSION COATING, PER MIL-DTL-5541F, CLASS 1A, TYPE II	A
	SPRING PIN	NICKEL STAINLESS STEEL	PASSIVATED	
2332834-2	HOUSING	STAINLESS STEEL PER ASTM A484 AND ASTM A582, TYPE 303	PASSIVATED	B
	SPRING PIN	NICKEL STAINLESS STEEL	PASSIVATED	
2332834-1	HOUSING	STAINLESS STEEL PER ASTM A484 AND ASTM A582, TYPE 303	PASSIVATED	A
	SPRING PIN	NICKEL STAINLESS STEEL	PASSIVATED	

THIS DRAWING IS A CONTROLLED DOCUMENT. DWG: J.L. MILLER 22FEB2019
 CHK: F. BLASICK 22FEB2019
 APPD: F. BLASICK 22FEB2019

DIMENSIONS: mm [INCHES]
 TOLERANCES UNLESS OTHERWISE SPECIFIED:
 0 PLC ±.05 [0.002]
 1 PLC ±0.13 [0.005]
 2 PLC ±0.13 [0.005]
 3 PLC ±0.13 [0.005]
 4 PLC ±.05 [0.002]
 ANGLES ±.05 [0.002]

MATERIAL: -
 FINISH: -

WEIGHT: -
 CUSTOMER DRAWING

NAME: VITA 67.3 DAUGHTER CARD MODULE
 9 POSN PER VITA 65.1 R6.4.5.6.2
 FOR SMPM STRAIGHT CABLE PLUG

SIZE: A1 | 00779 | C=2332834
 SCALE: 3:1 | SHEET 1 OF 1 | REV B