

PART NO.	ENG. NO.	MAT'L.	PLATE	WIRE GAGE	DIM. "B"	DIM. "C"	DIM. "D"	DIM. "E"	DIM. "F"	DIM. "G"
39-00-0207	5556-SP	A BRASS	TIN	18-24 GA.	.142±.012 (3.60±0.30)	.177±.016 (4.50±0.40)	.035 ±.016 (0.90)±0.40	.075±.012 (1.90±0.30)	.091±.016 (2.30±0.40)	.020 (0.50)
39-00-0208	5556-SPL				.091±.012 (2.30±0.30)	.091±.016 (2.30±0.40)	.024 ±.016 (0.60)±0.40	.071±.012 (1.80±0.30)	.065±.016 (1.65±0.40)	.016 (0.40)
39-00-0209	5556-S2P			16 GA.	.142±.012 (3.60±0.30)	.177±.016 (4.50±0.40)	.035 ±.016 (0.90)±0.40	.091±.012 (2.30±0.30)	.106±.016 (2.70±0.40)	.024 (0.60)
39-00-0210	5556-S2PL				.091±.012 (2.30±0.30)	.091±.016 (2.30±0.40)	.024 ±.016 (0.60)±0.40	.071±.012 (1.80±0.30)	.065±.016 (1.65±0.40)	.016 (0.40)
39-00-0211	5556-S3P				.142±.012 (3.60±0.30)	.177±.016 (4.50±0.40)	.035 ±.016 (0.90)±0.40	.091±.012 (2.30±0.30)	.106±.016 (2.70±0.40)	.024 (0.60)
39-00-0212	5556-S3PL	B PHOS BRONZE	TIN	18-24 GA.	.142±.012 (3.60±0.30)	.177±.016 (4.50±0.40)	.035 ±.016 (0.90)±0.40	.075±.012 (1.90±0.30)	.091±.016 (2.30±0.40)	.020 (0.50)
39-00-0213	5556-PBSP				.091±.012 (2.30±0.30)	.091±.016 (2.30±0.40)	.024 ±.016 (0.60)±0.40	.071±.012 (1.80±0.30)	.065±.016 (1.65±0.40)	.016 (0.40)
39-00-0214	5556-PBSPL			16 GA.	.142±.012 (3.60±0.30)	.177±.016 (4.50±0.40)	.035 ±.016 (0.90)±0.40	.091±.012 (2.30±0.30)	.106±.016 (2.70±0.40)	.024 (0.60)
39-00-0215	5556-PBS2P				.091±.012 (2.30±0.30)	.091±.016 (2.30±0.40)	.024 ±.016 (0.60)±0.40	.071±.012 (1.80±0.30)	.065±.016 (1.65±0.40)	.016 (0.40)
39-00-0216	5556-PBS2PL				.142±.012 (3.60±0.30)	.177±.016 (4.50±0.40)	.035 ±.016 (0.90)±0.40	.091±.012 (2.30±0.30)	.106±.016 (2.70±0.40)	.024 (0.60)
39-00-0217	5556-PBS3P			16 GA.	.142±.012 (3.60±0.30)	.177±.016 (4.50±0.40)	.035 ±.016 (0.90)±0.40	.091±.012 (2.30±0.30)	.106±.016 (2.70±0.40)	.024 (0.60)
39-00-0218	5556-PBS3PL	.091±.012 (2.30±0.30)	.091±.016 (2.30±0.40)		.024 ±.016 (0.60)±0.40	.071±.012 (1.80±0.30)	.065±.016 (1.65±0.40)	.016 (0.40)		

LEGEND:

5556 - ** S * P *

BASE NO. _____
MATERIAL _____
BLANK= BRASS
PB= PHOS. BRONZE
S= TIN OVER NICKEL
PLATING & CRIMP SIZE COMB. _____
BLANK THRU 5

CHAIN OR LOOSE _____
BLANK= CHAIN
L= LOOSE

NOTES

- MATERIAL:
A= BRASS
B= PHOS. BRONZE
- FINISH:
TIN = .000100/(.00254) MIN BRIGHT TIN OVER .000050/(.00127)MIN. NICKEL
- PRODUCT SPECIFICATION: PS-5556-001, PS-5556-002, PS-5556-003.
- PACKAGING SPECIFICATION: PK-5556-001 FOR CHAIN TERMINALS
PK-5556-003 FOR LOOSE TERMINALS.
- MATES WITH: 5558, 5566, 5569, 30069, 30070, 42440, 42404, 43879, 43810, 44068.
- APPLICABLE HOUSINGS: 5557, 30067, 43760, 44516, OR 42474.
- THE NUMBER OF SERRATIONS TO BE ONE FOR WIRE RANGE #22-28.
- WHEN TERMINALS ARE INSTALLED IN THE HOUSING THE WIRES ARE TO BE DRESSED IN SUCH A MANNER TO ALLOW THE TERMINALS TO FLOAT FREELY IN THE POCKET.
- THIS TERMINAL IS DESIGNED FOR SINGLE WIRE CRIMPING.
- PART CONFORMS TO CLASS "B" REQUIREMENTS OF COSMETIC SPECIFICATION PS-45499-002.
- TEXT ON PART IS FOR REFERENCE ONLY. TEXT AND TEXT LOCATION MAY VARY DEPENDING ON PART NUMBER AND/OR TOOL.

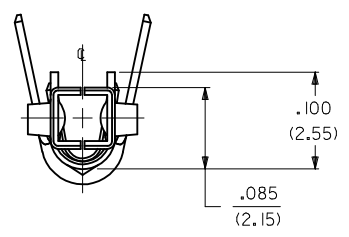
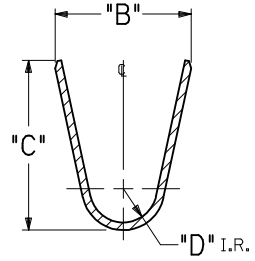
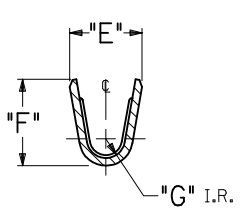
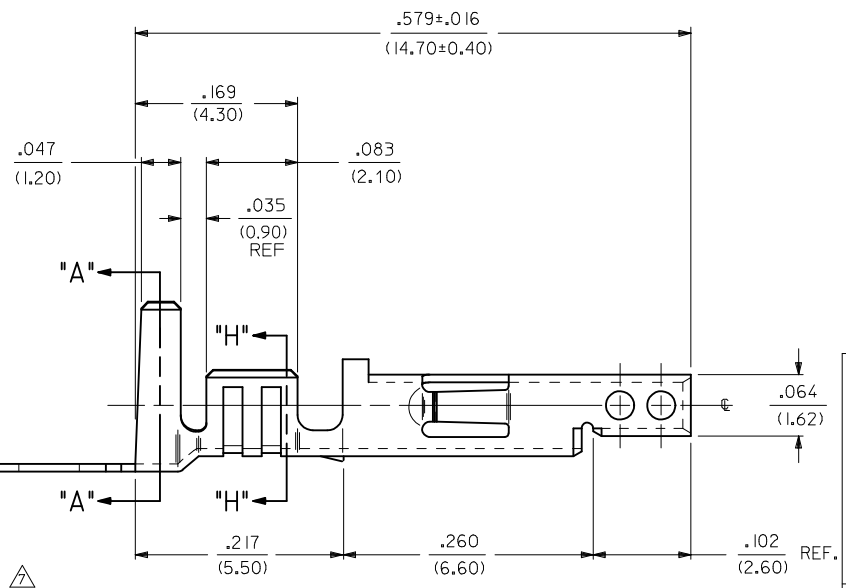
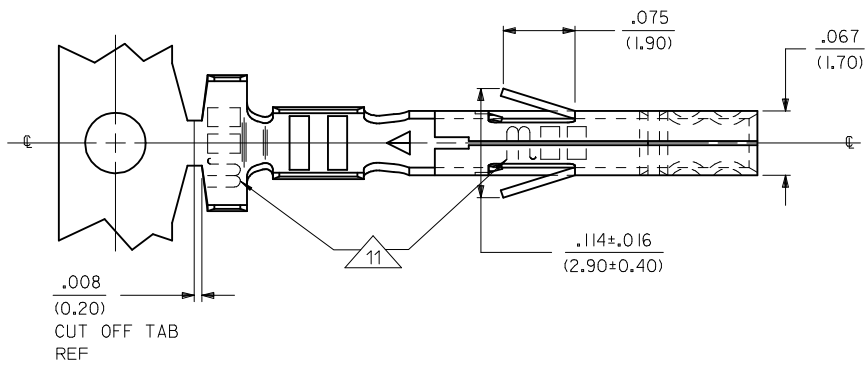

ADD NOTE 11 EC NO: UCP2017-2202 DRAWN: SLAFTER 2017/04/05 CHKD: J.BELL 2017/04/05 APPR: F.S.MITH 2017/09/29	QUALITY SYMBOLS ∇=0 ∇=0 ∇=0	GENERAL TOLERANCES (UNLESS SPECIFIED)		DIMENSION STYLE IN/MM		SCALE	DESIGN UNITS INCH	THIRD ANGLE PROJECTION		
		mm	INCH	DRAWN BY	DATE	TITLE MINI FIT JR OVERALL BRIGHT TIN OVER NICKEL FEMALE CRIMP TERMINAL				
		ANGULAR ±1/2° DRAFT WHERE APPLICABLE MUST REMAIN WITHIN DIMENSIONS		MATERIAL NO.	DATE	molex				
F3	REV	SEE CHART		APPROVED BY RAS 5/17/1990		DOCUMENT NO. SD-5556-SP*		SHEET NO. 1 OF 1		
THIS DRAWING CONTAINS INFORMATION THAT IS PROPRIETARY TO MOLEX INCORPORATED AND SHOULD NOT BE USED WITHOUT WRITTEN PERMISSION										

PART NO.	ENG. NO.	MAT'L.	PLATE	WIRE GAGE	DIM. "B"	DIM. "C"	DIM. "D"	DIM. "E"	DIM. "F"	DIM. "G"
39-00-0207	5556-SP	A BRASS	TIN	18-24 GA.	.142±.012 (3.60±0.30)	.177±.016 (4.50±0.40)	.035 ±.016 (0.90)±0.40	.075±.012 (1.90±0.30)	.091±.016 (2.30±0.40)	.020 (0.50)
39-00-0208	5556-SPL				.091±.012 (2.30±0.30)	.091±.016 (2.30±0.40)	.024 ±.016 (0.60)±0.40	.071±.012 (1.80±0.30)	.065±.016 (1.65±0.40)	.016 (0.40)
39-00-0209	5556-S2P			16 GA.	.142±.012 (3.60±0.30)	.177±.016 (4.50±0.40)	.035 ±.016 (0.90)±0.40	.091±.012 (2.30±0.30)	.106±.016 (2.70±0.40)	.024 (0.60)
39-00-0210	5556-S2PL				.091±.012 (2.30±0.30)	.091±.016 (2.30±0.40)	.024 ±.016 (0.60)±0.40	.071±.012 (1.80±0.30)	.065±.016 (1.65±0.40)	.016 (0.40)
39-00-0211	5556-S3P				.142±.012 (3.60±0.30)	.177±.016 (4.50±0.40)	.035 ±.016 (0.90)±0.40	.091±.012 (2.30±0.30)	.106±.016 (2.70±0.40)	.024 (0.60)
39-00-0212	5556-S3PL	B PHOS BRONZE	TIN	18-24 GA.	.142±.012 (3.60±0.30)	.177±.016 (4.50±0.40)	.035 ±.016 (0.90)±0.40	.075±.012 (1.90±0.30)	.091±.016 (2.30±0.40)	.020 (0.50)
39-00-0213	5556-PBSP				.091±.012 (2.30±0.30)	.091±.016 (2.30±0.40)	.024 ±.016 (0.60)±0.40	.071±.012 (1.80±0.30)	.065±.016 (1.65±0.40)	.016 (0.40)
39-00-0214	5556-PBSPL			16 GA.	.142±.012 (3.60±0.30)	.177±.016 (4.50±0.40)	.035 ±.016 (0.90)±0.40	.091±.012 (2.30±0.30)	.106±.016 (2.70±0.40)	.024 (0.60)
39-00-0215	5556-PBS2P				.091±.012 (2.30±0.30)	.091±.016 (2.30±0.40)	.024 ±.016 (0.60)±0.40	.071±.012 (1.80±0.30)	.065±.016 (1.65±0.40)	.016 (0.40)
39-00-0216	5556-PBS2PL				.142±.012 (3.60±0.30)	.177±.016 (4.50±0.40)	.035 ±.016 (0.90)±0.40	.091±.012 (2.30±0.30)	.106±.016 (2.70±0.40)	.024 (0.60)
39-00-0217	5556-PBS3P	16 GA.	.142±.012 (3.60±0.30)	.177±.016 (4.50±0.40)	.035 ±.016 (0.90)±0.40	.091±.012 (2.30±0.30)	.106±.016 (2.70±0.40)	.024 (0.60)		
39-00-0218	5556-PBS3PL		.091±.012 (2.30±0.30)	.091±.016 (2.30±0.40)	.024 ±.016 (0.60)±0.40	.071±.012 (1.80±0.30)	.065±.016 (1.65±0.40)	.016 (0.40)		

LEGEND:

5556 - ** S * P *

BASE NO. _____
MATERIAL _____
BLANK= BRASS
PB= PHOS. BRONZE
S= TIN OVER NICKEL
PLATING & CRIMP SIZE COMB. _____
BLANK THRU 5

CHAIN OR LOOSE _____
BLANK= CHAIN
L= LOOSE

NOTES

- MATERIAL:
A= BRASS
B= PHOS. BRONZE
- FINISH:
TIN = .000100/(.00254) MIN BRIGHT TIN OVER .000050/(.00127)MIN. NICKEL
- PRODUCT SPECIFICATION: PS-5556-001, PS-5556-002, PS-5556-003.
- PACKAGING SPECIFICATION: PK-5556-001 FOR CHAIN TERMINALS
PK-5556-003 FOR LOOSE TERMINALS.
- MATES WITH: 5558, 5566, 5569, 30069, 30070, 42440, 42404, 43879, 43810, 44068.
- APPLICABLE HOUSINGS: 5557, 30067, 43760, 44516, OR 42474.
- THE NUMBER OF SERRATIONS TO BE ONE FOR WIRE RANGE #22-28.
- WHEN TERMINALS ARE INSTALLED IN THE HOUSING THE WIRES ARE TO BE DRESSED IN SUCH A MANNER TO ALLOW THE TERMINALS TO FLOAT FREELY IN THE POCKET.
- THIS TERMINAL IS DESIGNED FOR SINGLE WIRE CRIMPING.
- PART CONFORMS TO CLASS "B" REQUIREMENTS OF COSMETIC SPECIFICATION PS-45499-002.
- TEXT ON PART IS FOR REFERENCE ONLY. TEXT AND TEXT LOCATION MAY VARY DEPENDING ON PART NUMBER AND/OR TOOL.

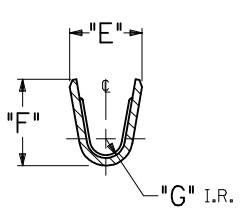
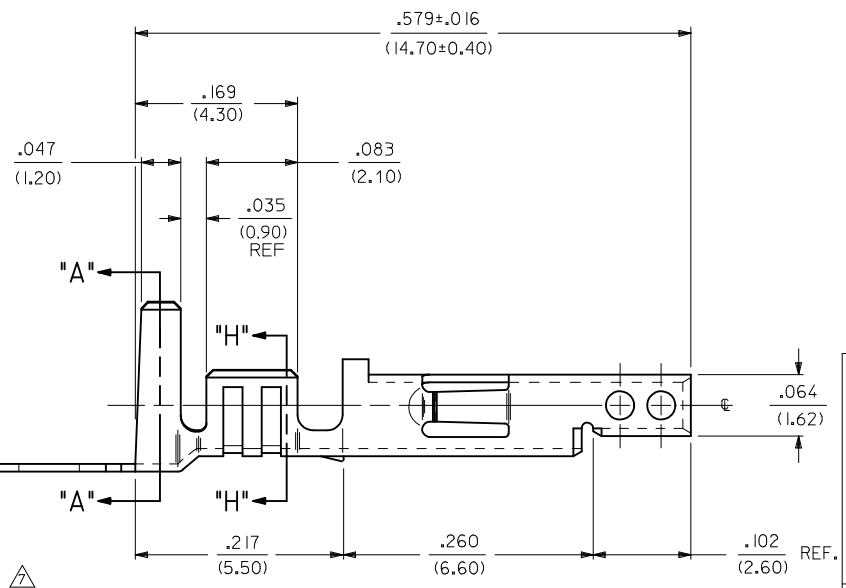
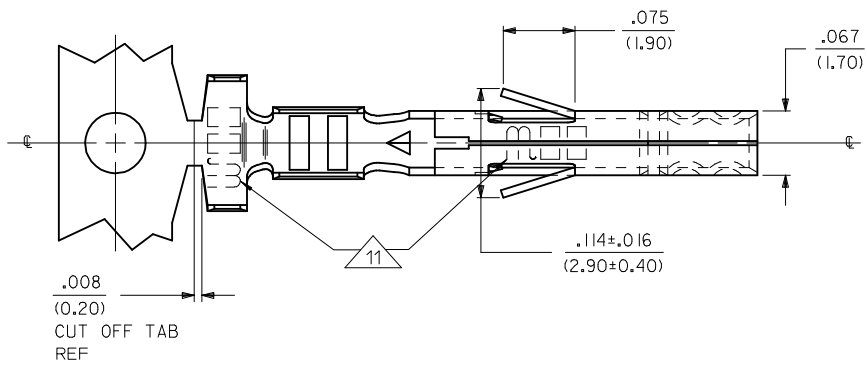

SECT. "H-H"

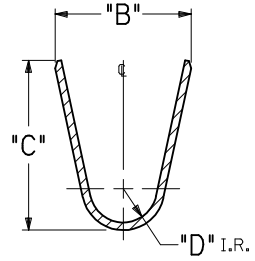

SECT. "A-A"

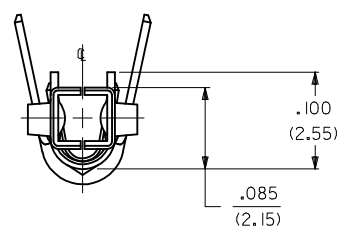

ADD NOTE 11 EC NO: UCP2017-2202 DRAWN: SLAFTER 2017/04/05 CHKD: J.BELL 2017/04/05 APPR: F.S.MITH 2017/09/29	QUALITY SYMBOLS ∇=0 ∇=0 ∇=0	GENERAL TOLERANCES (UNLESS SPECIFIED)		DIMENSION STYLE IN/MM		SCALE INCH	DESIGN UNITS INCH	THIRD ANGLE PROJECTION	
		mm	INCH	DRAWN BY	DATE	TITLE MINI FIT JR OVERALL BRIGHT TIN OVER NICKEL FEMALE CRIMP TERMINAL			
		4 PLACES ± --- ± ---	3 PLACES ± --- ± .010	2 PLACES ± 0.25 ± .014	1 PLACE ± 0.36 ± ---	0 PLACE ± ±	APPROVED BY	DATE	molex
ANGULAR ±1/2° DRAFT WHERE APPLICABLE MUST REMAIN WITHIN DIMENSIONS		MATERIAL NO. SEE CHART		DOCUMENT NO. SD-5556-SP*		SHEET NO. 1 OF 1			
THIS DRAWING CONTAINS INFORMATION THAT IS PROPRIETARY TO MOLEX INCORPORATED AND SHOULD NOT BE USED WITHOUT WRITTEN PERMISSION									