

SN74CB3Q3253 Dual 1-of-4 FET Multiplexer – Demultiplexer

2.5-V – 3.3-V Low-Voltage High-Bandwidth Bus Switch

1 Features

- High-Bandwidth Data Path (Up to 500 MHz) ⁽¹⁾
- 5-V Tolerant I/Os With Device Powered Up or Powered Down
- Low and Flat ON-State Resistance (r_{on}) Characteristics Over Operating Range ($r_{on} = 4 \Omega$ Typical)
- Rail-to-Rail Switching on Data I/O Ports
 - 0- to 5-V Switching With 3.3-V V_{CC}
 - 0- to 3.3-V Switching With 2.5-V V_{CC}
- Bidirectional Data Flow With Near-Zero Propagation Delay
- Low Input/Output Capacitance Minimizes Loading and Signal Distortion ($C_{iO(OFF)} = 3.5$ pF Typical)
- Fast Switching Frequency ($f_{OE} = 20$ MHz Max)
- Data and Control Inputs Provide Undershoot Clamp Diodes
- Low Power Consumption ($I_{CC} = 0.6$ mA Typical)
- V_{CC} Operating Range From 2.3 V to 3.6 V
- Data I/Os Support 0- to 5-V Signal Levels (0.8-V, 1.2-V, 1.5-V, 1.8-V, 2.5-V, 3.3-V, 5-V)
- Control Inputs Can be Driven by TTL or 5-V and 3.3-V CMOS Outputs
- I_{off} Supports Partial-Power-Down Mode Operation
- Latch-Up Performance Exceeds 100 mA Per JESD 78, Class II
- ESD Performance Tested Per JESD 22
 - 2000-V Human-Body Model (A114-B, Class II)
 - 1000-V Charged-Device Model (C101)
- Supports Both Digital and Analog Applications: USB Interface, Differential Signal Interface Bus Isolation, Low-Distortion Signal Gating

⁽¹⁾ For additional information regarding the performance characteristics of the CB3Q family, refer to the TI application report *CBT-C, CB3T, and CB3Q Signal-Switch Families*, (SCDA008).

2 Applications

- Video Broadcasting: IP-Based Multi-Format Transcoder
- Video Communications System

3 Description

The SN74CB3Q3253 device is a high-bandwidth FET bus switch using a charge pump to elevate the gate voltage of the pass transistor, providing a low and flat ON-state resistance (r_{on}). The low and flat ON-state resistance allows for minimal propagation delay and supports rail-to-rail switching on the data input and output (I/O) ports.

Device Information

PART NUMBER	PACKAGE	BODY SIZE (NOM)
SN74CB3Q3253DBQ	SSOP (16)	4.90 mm × 3.90 mm
SN74CB3Q3253DGV	TVSOP (16)	3.60 mm × 4.40 mm
SN74CB3Q3253RGY	VQFN (16)	4.00 mm × 3.50 mm
SN74CB3Q3253PW	TSSOP (16)	5.00 mm × 4.40 mm

⁽¹⁾ For all available packages, see the orderable addendum at the end of the data sheet.

Logic Diagram (Positive Logic)

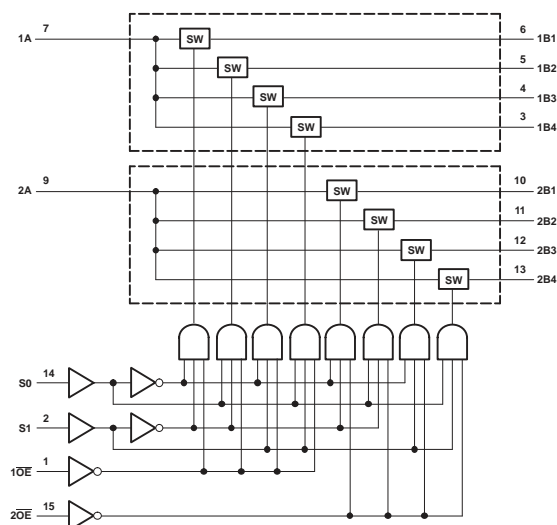

Table of Contents

1 Features 1 2 Applications 1 3 Description 1 4 Revision History 2 5 Pin Configuration and Functions 3 6 Specifications 4 6.1 Absolute Maximum Ratings 4 6.2 ESD Ratings 4 6.3 Recommended Operating Conditions 4 6.4 Thermal Information 5 6.5 Electrical Characteristics 5 6.6 Switching Characteristics 6 6.7 Typical Characteristics 6 7 Parameter Measurement Information 7 8 Detailed Description 8 8.1 Overview 8 8.2 Functional Block Diagram 9	8.3 Feature Description 9 8.4 Device Functional Modes 9 9 Application and Implementation 10 9.1 Application Information 10 9.2 Typical Application 10 10 Power Supply Recommendations 11 11 Layout 12 11.1 Layout Guidelines 12 11.2 Layout Example 12 12 Device and Documentation Support 13 12.1 Documentation Support 13 12.2 Receiving Notification of Documentation Updates 13 12.3 Community Resources 13 12.4 Trademarks 13 12.5 Electrostatic Discharge Caution 13 12.6 Glossary 13 13 Mechanical, Packaging, and Orderable Information 13
---	---

4 Revision History

Changes from Revision B (June 2015) to Revision C	Page
• Changed the pinout image appearance	3
• Updated the <i>Thermal Information</i> table	5
Changes from Revision A (November 2003) to Revision B	Page
• Removed <i>Ordering Information</i> table	1
• Added <i>Applications</i> , <i>Device Information</i> table, <i>Pin Configuration and Functions</i> section, <i>Storage Conditions</i> table, <i>ESD Ratings</i> table, <i>Feature Description</i> section, <i>Device Functional Modes</i> , <i>Application and Implementation</i> section, <i>Power Supply Recommendations</i> section, <i>Layout</i> section, <i>Device and Documentation Support</i> section, and <i>Mechanical, Packaging, and Orderable Information</i> section	1

5 Pin Configuration and Functions

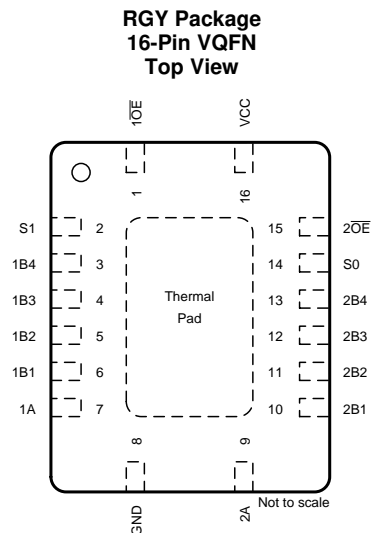
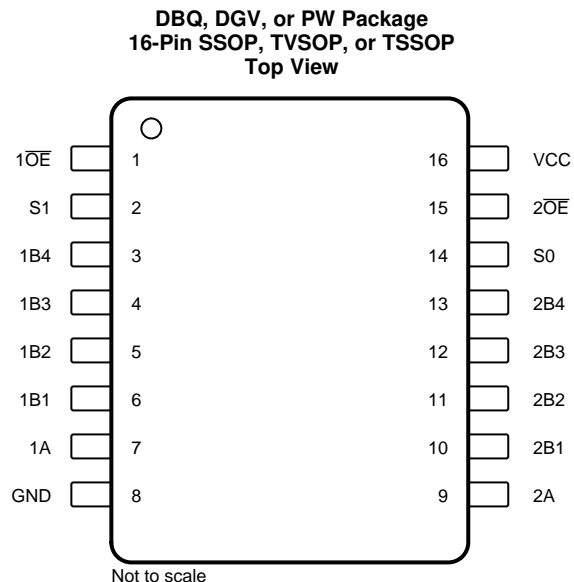

Pin Functions

PIN		I/O	DESCRIPTION
NAME	NO.		
$1\overline{OE}$	1	I	Output Enable 1 Active-Low
S1	2	I	Select Pin 1
1B4	3	I/O	Channel 1 I/O 4
1B3	4	I/O	Channel 1 I/O 3
1B2	5	I/O	Channel 1 I/O 2
1B1	6	I/O	Channel 1 I/O 1
1A	7	I/O	Channel 1 common
GND	8	—	Ground
2A	9	I/O	Channel 2 common
2B1	10	I/O	Channel 2 I/O 1
2B2	11	I/O	Channel 2 I/O 2
2B3	12	I/O	Channel 2 I/O 3
2B4	13	I/O	Channel 2 I/O 4
S0	14	I	Select Pin 0
$2\overline{OE}$	15	I	Output Enable 2 Active-Low
V _{CC}	16	—	Power

6 Specifications

6.1 Absolute Maximum Ratings

over operating free-air temperature range (unless otherwise noted)⁽¹⁾

		MIN	MAX	UNIT
V_{CC}	Supply voltage	-0.5	4.6	V
V_{IN}	Control input voltage ⁽²⁾⁽³⁾	-0.5	7	V
$V_{I/O}$	Switch I/O voltage ⁽²⁾⁽³⁾⁽⁴⁾	-0.5	7	V
I_{IK}	Control input clamp current	$V_{IN} < 0$	-50	mA
$I_{I/OK}$	I/O port clamp current	$V_{I/O} < 0$	-50	mA
$I_{I/O}$	ON-state switch current ⁽⁵⁾		±64	mA
	Continuous current through V_{CC} or GND		±100	mA
T_{stg}	Storage temperature	-65	150	°C

- (1) Stresses beyond those listed under *Absolute Maximum Ratings* may cause permanent damage to the device. These are stress ratings only, and functional operation of the device at these or any other conditions beyond those indicated under *Recommended Operating Conditions* is not implied. Exposure to absolute-maximum-rated conditions for extended periods may affect device reliability.
- (2) All voltages are with respect to ground, unless otherwise specified.
- (3) The input and output voltage ratings may be exceeded if the input and output clamp-current ratings are observed.
- (4) V_I and V_O are used to denote specific conditions for $V_{I/O}$.
- (5) I_I and I_O are used to denote specific conditions for $I_{I/O}$.

6.2 ESD Ratings

		VALUE	UNIT
$V_{(ESD)}$	Electrostatic discharge	Human body model (HBM), per ANSI/ESDA/JEDEC JS-001 ⁽¹⁾	+2000
		Charged-device model (CDM), per JEDEC specification JESD22-C101 ⁽²⁾	+1000
			V

- (1) JEDEC document JEP155 states that 500-V HBM allows safe manufacturing with a standard ESD control process.
- (2) JEDEC document JEP157 states that 250-V CDM allows safe manufacturing with a standard ESD control process.

6.3 Recommended Operating Conditions

over operating free-air temperature range (unless otherwise noted)⁽¹⁾

		MIN	MAX	UNIT
V_{CC}	Supply voltage	2.3	3.6	V
V_{IH}	High-level control input voltage	$V_{CC} = 2.3\text{ V to }2.7\text{ V}$	1.7	5.5
		$V_{CC} = 2.7\text{ V to }3.6\text{ V}$	2	5.5
V_{IL}	Low-level control input voltage	$V_{CC} = 2.3\text{ V to }2.7\text{ V}$	0	0.7
		$V_{CC} = 2.7\text{ V to }3.6\text{ V}$	0	0.8
$V_{I/O}$	Data input/output voltage	0	5.5	V
T_A	Operating free-air temperature	-40	85	°C

- (1) All unused control inputs of the device must be held at V_{CC} or GND to ensure proper device operation. Refer to the TI application report, *Implications of Slow or Floating CMOS Inputs*, (SCBA004).

6.4 Thermal Information

THERMAL METRIC ⁽¹⁾	SN74CB3Q3253				UNIT
	DBQ (SSOP)	DGV (TVSOP)	PW (TSSOP)	RGY (VQFN)	
	16 PINS	16 PINS	16 PINS	16 PINS	
R _{θJA} Junction-to-ambient thermal resistance	114.3	126	112.7	45.7	°C/W
R _{θJC(top)} Junction-to-case (top) thermal resistance	65.4	51.3	47.5	59.6	°C/W
R _{θJB} Junction-to-board thermal resistance	56.8	57.8	57.85	23.3	°C/W
ψ _{JT} Junction-to-top characterization parameter	18.3	5.9	6	2.2	°C/W
ψ _{JB} Junction-to-board characterization parameter	56.4	57.3	57.3	23.4	°C/W
R _{θJC(bot)} Junction-to-case (bottom) thermal resistance	n/a	n/a	n/a	11.5	°C/W

(1) For more information about traditional and new thermal metrics, see the [Semiconductor and IC Package Thermal Metrics](#) application report.

6.5 Electrical Characteristics

over recommended operating free-air temperature range (unless otherwise noted)⁽¹⁾

PARAMETER	TEST CONDITIONS		MIN	TYP ⁽²⁾	MAX	UNIT
V _{IK}	V _{CC} = 3.6 V,	I _I = -18 mA			-1.8	V
I _{IN} Control inputs	V _{CC} = 3.6 V,	V _{IN} = 0 to 5.5 V			±1	μA
I _{OZ} ⁽³⁾	V _{CC} = 3.6 V,	V _O = 0 to 5.5 V, V _I = 0, Switch OFF, V _{IN} = V _{CC} or GND			±1	μA
I _{off}	V _{CC} = 0,	V _O = 0 to 5.5 V, V _I = 0			1	μA
I _{CC}	V _{CC} = 3.6 V,	I _{I/O} = 0, Switch ON or OFF, V _{IN} = V _{CC} or GND		0.6	2	mA
ΔI _{CC} ⁽⁴⁾ Control inputs	V _{CC} = 3.6 V,	One input at 3 V, Other inputs at V _{CC} or GND			30	μA
I _{CCD} ⁽⁵⁾ Per control input	V _{CC} = 3.6 V, Control input switching at 50% duty cycle	A and B ports open, OE input		0.15	0.16	mA/ MHz
		S input		0.04	0.05	
C _{in} Control inputs	V _{CC} = 3.3 V,	V _{IN} = 5.5 V, 3.3 V, or 0		2.5	3.5	pF
C _{io(OFF)}	A port	V _{CC} = 3.3 V, Switch OFF, V _{IN} = V _{CC} or GND, V _{I/O} = 5.5 V, 3.3 V, or 0		8	11	pF
	B port	V _{CC} = 3.3 V, Switch OFF, V _{IN} = V _{CC} or GND, V _{I/O} = 5.5 V, 3.3 V, or 0		3.5	4.5	pF
C _{io(ON)}	V _{CC} = 3.3 V,	Switch ON, V _{IN} = V _{CC} or GND, V _{I/O} = 5.5 V, 3.3 V, or 0		13	17	pF
r _{on} ⁽⁶⁾	V _{CC} = 2.3 V, TYP at V _{CC} = 2.5 V	V _I = 0, I _O = 30 mA		4	10	Ω
		V _I = 1.7 V, I _O = -15 mA		4.5	11	
	V _{CC} = 3 V	V _I = 0, I _O = 30 mA		3.5	8	
		V _I = 2.4 V, I _O = -15 mA		4	10	

(1) V_{IN} and I_{IN} refer to control inputs. V_I, V_O, I_I, and I_O refer to data pins.

(2) All typical values are at V_{CC} = 3.3 V (unless otherwise noted), T_A = 25°C.

(3) For I/O ports, the parameter I_{OZ} includes the input leakage current.

(4) This is the increase in supply current for each input that is at the specified TTL voltage level, rather than V_{CC} or GND.

(5) This parameter specifies the dynamic power-supply current associated with the operating frequency of a single control input (see [Figure 2](#)).

(6) Measured by the voltage drop between the A and B terminals at the indicated current through the switch. ON-state resistance is determined by the lower of the voltages of the two (A or B) terminals.

6.6 Switching Characteristics

over recommended operating free-air temperature range (unless otherwise noted) (see Figure 3)

PARAMETER	FROM (INPUT)	TO (OUTPUT)	V _{CC} = 2.5 V ± 0.2 V		V _{CC} = 3.3 V ± 0.3 V		UNIT
			MIN	MAX	MIN	MAX	
f _{OE} or f _S ⁽¹⁾	OE or S	A or B		10		20	MHz
t _{pd} ⁽²⁾	A or B	B or A		0.12		0.18	ns
t _{pd(s)}	S	A	1.5	6.7	1.5	5.9	ns
t _{en}	S	B	1.5	6.7	1.5	5.9	ns
	OE	A or B	1.5	6.7	1.5	5.9	
t _{dis}	S	B	1	6.1	1	6.1	ns
	OE	A or B	1	6.1	1	6.1	

- (1) Maximum switching frequency for control input (V_O > V_{CC}, V_I = 5 V, R_L ≥ 1 MΩ, C_L = 0).
- (2) The propagation delay is the calculated RC time constant of the typical ON-state resistance of the switch and the specified load capacitance, when driven by an ideal voltage source (zero output impedance).

6.7 Typical Characteristics

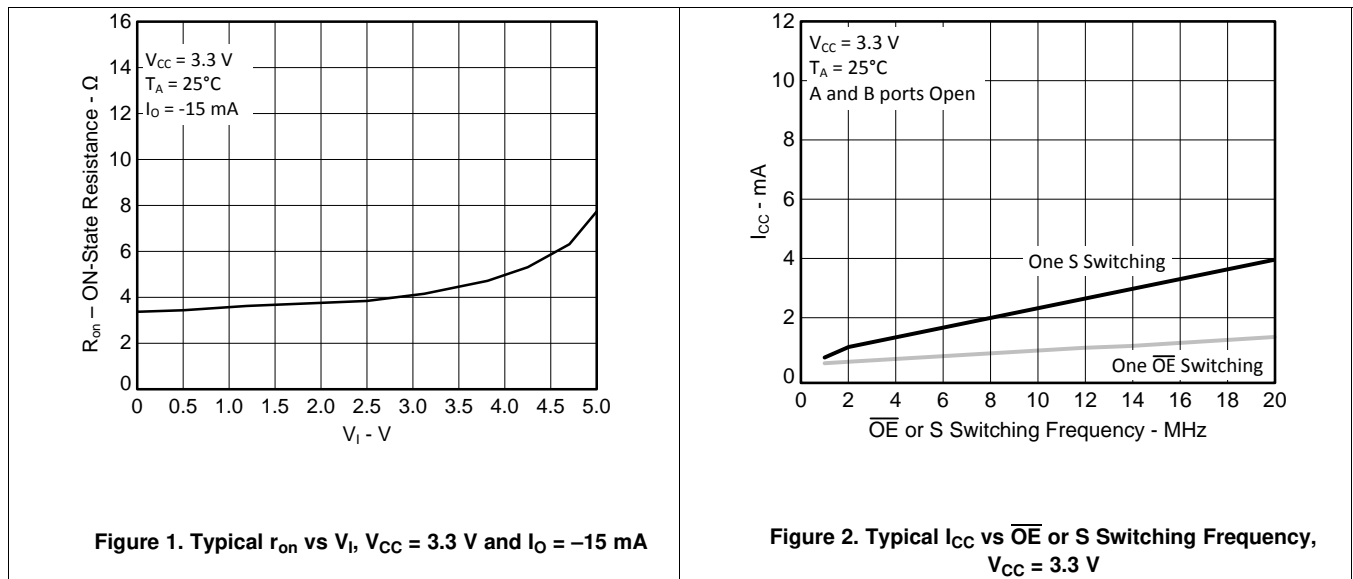

7 Parameter Measurement Information

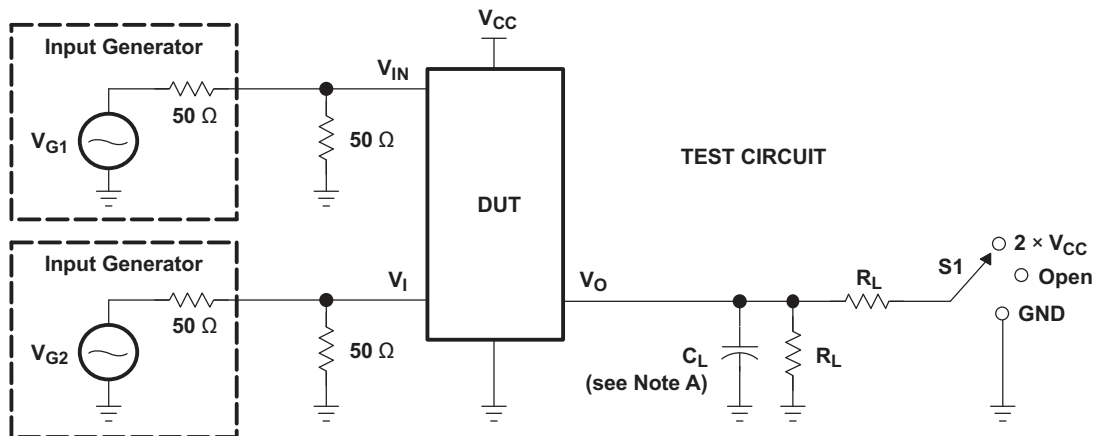

TEST	V _{CC}	S1	R _L	V _I	C _L	V _Δ
t _{pd(s)}	2.5 V ± 0.2 V	Open	500 Ω	V _{CC} or GND	30 pF	
	3.3 V ± 0.3 V	Open	500 Ω	V _{CC} or GND	50 pF	
t _{PLZ} /t _{PZL}	2.5 V ± 0.2 V	2 × V _{CC}	500 Ω	GND	30 pF	0.15 V
	3.3 V ± 0.3 V	2 × V _{CC}	500 Ω	GND	50 pF	0.3 V
t _{PHZ} /t _{PZH}	2.5 V ± 0.2 V	GND	500 Ω	V _{CC}	30 pF	0.15 V
	3.3 V ± 0.3 V	GND	500 Ω	V _{CC}	50 pF	0.3 V

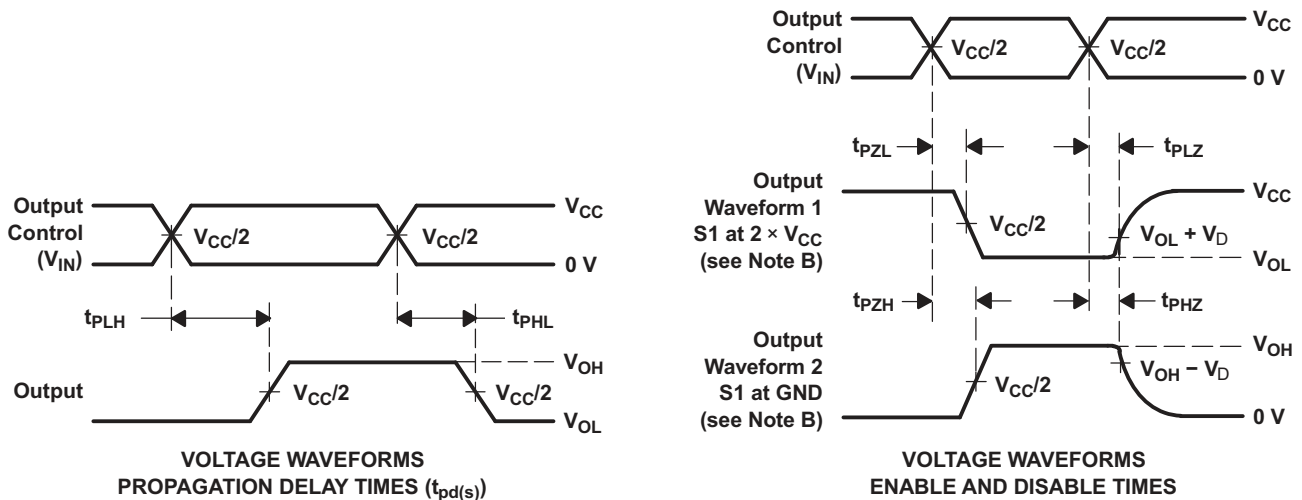

- NOTES:
- A. C_L includes probe and jig capacitance.
 - B. Waveform 1 is for an output with internal conditions such that the output is low except when disabled by the output control. Waveform 2 is for an output with internal conditions such that the output is high, except when disabled by the output control.
 - C. All input pulses are supplied by generators having the following characteristics: PRR ≤ 10 MHz, Z_O = 50 Ω, t_r ≤ 2.5 ns, t_f ≤ 2.5 ns.
 - D. The outputs are measured one at a time, with one transition per measurement.
 - E. t_{PLZ} and t_{PHZ} are the same as t_{dis}.
 - F. t_{PZL} and t_{PZH} are the same as t_{en}.
 - G. t_{PLH} and t_{PHL} are the same as t_{pd(s)}. The t_{pd} propagation delay is the calculated RC time constant of the typical ON-state resistance of the switch and the specified load capacitance, when driven by an ideal voltage source (zero output impedance).
 - H. All parameters and waveforms are not applicable to all devices.

Figure 3. Test Circuit and Voltage Waveforms

8 Detailed Description

8.1 Overview

The SN74CB3Q3253 device is a high-bandwidth FET bus switch using a charge pump to elevate the gate voltage of the pass transistor, providing a low and flat ON-state resistance (r_{on}). The low and flat ON-state resistance allows for minimal propagation delay and supports rail-to-rail switching on the data input/output (I/O) ports. The device also features low data I/O capacitance to minimize capacitive loading and signal distortion on the data bus. Specifically designed to support high-bandwidth applications, the SN74CB3Q3253 device provides an optimized interface solution ideally suited for broadband communications, networking, and data-intensive computing systems.

The SN74CB3Q3253 device is organized as two 1-of-4 multiplexers/demultiplexers with separate output-enable ($1\overline{OE}$, $2\overline{OE}$) inputs. The select (S0, S1) inputs control the data path of each multiplexer/demultiplexer. When \overline{OE} is low, the associated multiplexer/demultiplexer is enabled, and the A port is connected to the B port, allowing bidirectional data flow between ports. When \overline{OE} is high, the associated multiplexer/demultiplexer is disabled, and a high-impedance state exists between the A and B ports.

This device is fully specified for partial-power-down applications using I_{off} . The I_{off} circuitry prevents damaging current backflow through the device when it is powered down. The device has isolation during power off.

To ensure the high-impedance state during power up or power down, \overline{OE} should be tied to V_{CC} through a pullup resistor; the minimum value of the resistor is determined by the current-sinking capability of the driver.

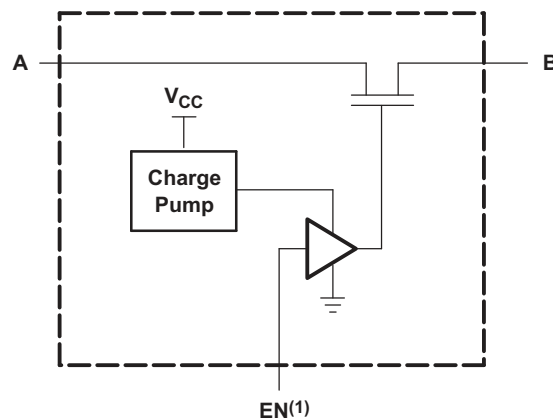

(1) EN is the internal enable signal applied to the switch.

Figure 4. Simplified Schematic, Each FET Switch (SW)

8.2 Functional Block Diagram

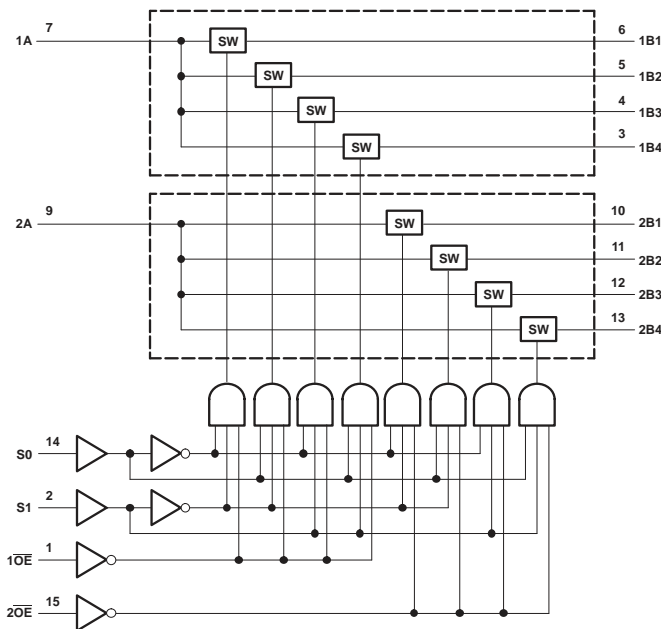

8.3 Feature Description

The SN74CB3Q3253 device has a high-bandwidth data path (up to 500 MHz) and has 5-V tolerant I/Os with the device powered up or powered down. It also has low and flat ON-state resistance (r_{on}) characteristics over operating range ($r_{on} = 4 \Omega$ Typical)

This device also has rail-to-rail switching on data I/O ports for 0- to 5-V switching with 3.3-V V_{CC} and 0- to 3.3-V switching with 2.5-V V_{CC} as well as bidirectional data flow with near-zero propagation delay and low input and output capacitance that minimizes loading and signal distortion ($C_{iO(OFF)} = 3.5$ pF Typical)

The SN74CB3Q3253 also provides a fast switching frequency ($f_{OE} = 20$ MHz Maximum) with data and control inputs that provide undershoot clamp diodes as well as low power consumption ($I_{CC} = 0.6$ mA Typical)

The V_{CC} operating range is from 2.3 V to 3.6 V and the data I/Os support 0- to 5-V signal levels of (0.8-V, 1.2-V, 1.5-V, 1.8-V, 2.5-V, 3.3-V, 5-V)

The control inputs can be driven by TTL or 5-V and 3.3-V CMOS outputs as well as I_{off} Supports Partial-Power-Down Mode Operation

8.4 Device Functional Modes

Table 1 lists the functional modes of the SN74CB3Q3253.

**Table 1. Function Table
(Each Multiplexer/Demultiplexer)**

INPUTS			INPUT/OUTPUT	FUNCTION
\overline{OE}	S1	S0	A	
L	L	L	B1	A port = B1 port
L	L	H	B2	A port = B2 port
L	H	L	B3	A port = B3 port
L	H	H	B4	A port = B4 port
H	X	X	Z	Disconnect

9 Application and Implementation

NOTE

Information in the following applications sections is not part of the TI component specification, and TI does not warrant its accuracy or completeness. TI's customers are responsible for determining suitability of components for their purposes. Customers should validate and test their design implementation to confirm system functionality.

9.1 Application Information

The SN74CB3Q3253 device can be used to multiplex and demultiplex up to 4 channels simultaneously in a 2:1 configuration.

9.2 Typical Application

The application shown here is a 4-bit bus being multiplexed between two devices. the \overline{OE} and S pins are used to control the chip from the bus controller. This is a very generic example, and could apply to many situations. If an application requires less than 4 bits, be sure to tie the A side to either high or low on unused channels.

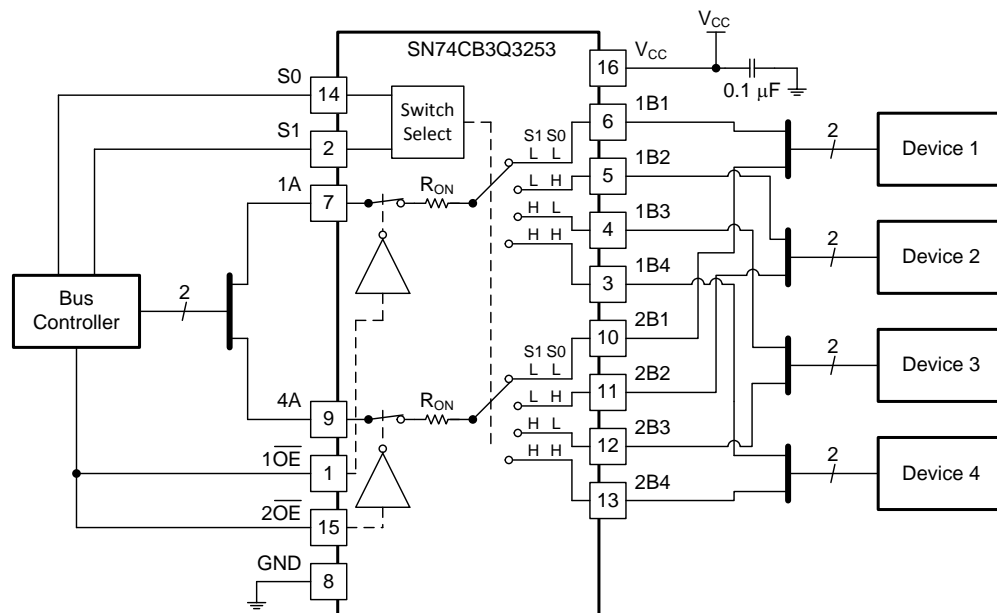

Figure 5. Typical Application of the SN74CB3Q3253

9.2.1 Design Requirements

The 0.1- μ F capacitor should be placed as close as possible to the device.

9.2.2 Detailed Design Procedure

1. Recommended Input Conditions:
 - For specified high and low levels, see V_{IH} and V_{IL} in [Recommended Operating Conditions](#).
 - Inputs and outputs are overvoltage tolerant allowing them to go as high as 4.6 V at any valid V_{CC} .
2. Recommended Output Conditions:
 - Load currents should not exceed ± 128 mA per channel.
3. Frequency Selection Criterion:
 - Maximum frequency tested is 500 MHz.
 - Added trace resistance and capacitance can reduce maximum frequency capability; use layout practices as directed in [Layout](#).

Typical Application (continued)

9.2.3 Application Curve

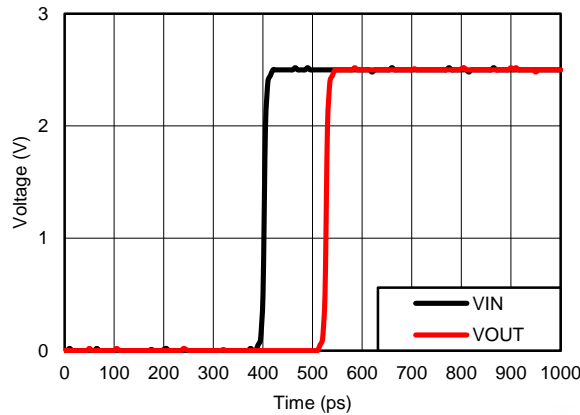

Figure 6. Propagation Delay (t_{pd}) Simulation Result at $V_{CC} = 2.5\text{ V}$

10 Power Supply Recommendations

The power supply can be any voltage between the minimum and maximum supply voltage rating listed in the [Absolute Maximum Ratings](#) table.

Each V_{CC} terminal should have a good bypass capacitor to prevent power disturbance. For devices with a single supply, a 0.1- μF bypass capacitor is recommended. If multiple pins are labeled V_{CC} , then a 0.01- μF or 0.022- μF capacitor is recommended for each V_{CC} because the V_{CC} pins are tied together internally. For devices with dual-supply pins operating at different voltages, for example V_{CC} and V_{DD} , a 0.1- μF bypass capacitor is recommended for each supply pin. To reject different frequencies of noise, use multiple bypass capacitors in parallel. Capacitors with values of 0.1 μF and 1 μF are commonly used in parallel. The bypass capacitor should be installed as close to the power terminal as possible for best results.

11 Layout

11.1 Layout Guidelines

Reflections and matching are closely related to the loop antenna theory but are different enough to be discussed separately from the theory. When a PCB trace turns a corner at a 90° angle, a reflection can occur. A reflection occurs primarily because of the change of width of the trace. At the apex of the turn, the trace width increases to 1.414 times the width. This increase upsets the transmission-line characteristics, especially the distributed capacitance and self-inductance of the trace which results in the reflection. Not all PCB traces can be straight and therefore some traces must turn corners. [Figure 7](#) shows progressively better techniques of rounding corners. Only the last example (BEST) maintains constant trace width and minimizes reflections.

11.2 Layout Example

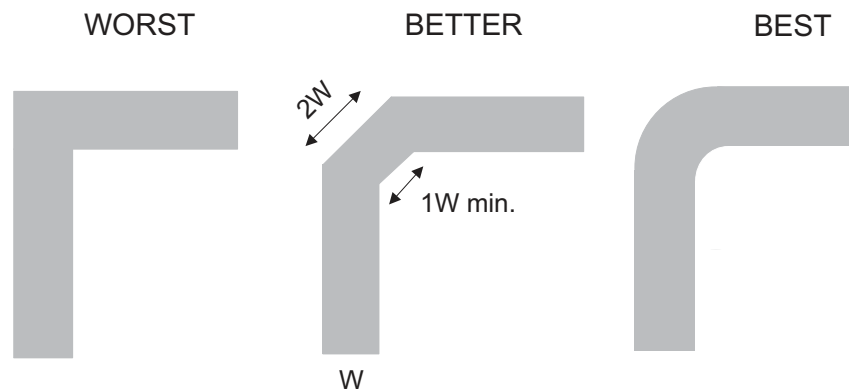

Figure 7. Trace Example

12 Device and Documentation Support

12.1 Documentation Support

12.1.1 Related Documentation

For related documentation see the following:

- *Implications of Slow or Floating CMOS Inputs*, [SCBA004](#)
- *Selecting the Right Texas Instruments Signal Switch*, [SZZA030](#)

12.2 Receiving Notification of Documentation Updates

To receive notification of documentation updates, navigate to the device product folder on ti.com. In the upper right corner, click on *Alert me* to register and receive a weekly digest of any product information that has changed. For change details, review the revision history included in any revised document.

12.3 Community Resources

The following links connect to TI community resources. Linked contents are provided "AS IS" by the respective contributors. They do not constitute TI specifications and do not necessarily reflect TI's views; see TI's [Terms of Use](#).

TI E2E™ Online Community *TI's Engineer-to-Engineer (E2E) Community*. Created to foster collaboration among engineers. At e2e.ti.com, you can ask questions, share knowledge, explore ideas and help solve problems with fellow engineers.

Design Support *TI's Design Support* Quickly find helpful E2E forums along with design support tools and contact information for technical support.

12.4 Trademarks

E2E is a trademark of Texas Instruments.

All other trademarks are the property of their respective owners.

12.5 Electrostatic Discharge Caution



These devices have limited built-in ESD protection. The leads should be shorted together or the device placed in conductive foam during storage or handling to prevent electrostatic damage to the MOS gates.

12.6 Glossary

[SLYZ022](#) — *TI Glossary*.

This glossary lists and explains terms, acronyms, and definitions.

13 Mechanical, Packaging, and Orderable Information

The following pages include mechanical, packaging, and orderable information. This information is the most current data available for the designated devices. This data is subject to change without notice and revision of this document. For browser-based versions of this data sheet, refer to the left-hand navigation.

PACKAGING INFORMATION

Orderable Device	Status (1)	Package Type	Package Drawing	Pins	Package Qty	Eco Plan (2)	Lead finish/ Ball material (6)	MSL Peak Temp (3)	Op Temp (°C)	Device Marking (4/5)	Samples
SN74CB3Q3253DBQR	ACTIVE	SSOP	DBQ	16	2500	RoHS & Green	NIPDAU	Level-2-260C-1 YEAR	-40 to 85	BU253	Samples
SN74CB3Q3253DGVR	ACTIVE	TVSOP	DGV	16	2000	RoHS & Green	NIPDAU	Level-1-260C-UNLIM	-40 to 85	BU253	Samples
SN74CB3Q3253PW	ACTIVE	TSSOP	PW	16	90	RoHS & Green	NIPDAU	Level-1-260C-UNLIM	-40 to 85	BU253	Samples
SN74CB3Q3253PWR	ACTIVE	TSSOP	PW	16	2000	RoHS & Green	NIPDAU	Level-1-260C-UNLIM	-40 to 85	BU253	Samples
SN74CB3Q3253PWRE4	ACTIVE	TSSOP	PW	16	2000	RoHS & Green	NIPDAU	Level-1-260C-UNLIM	-40 to 85	BU253	Samples
SN74CB3Q3253PWRG4	ACTIVE	TSSOP	PW	16	2000	RoHS & Green	NIPDAU	Level-1-260C-UNLIM	-40 to 85	BU253	Samples
SN74CB3Q3253RGYR	ACTIVE	VQFN	RGY	16	3000	RoHS & Green	NIPDAU	Level-2-260C-1 YEAR	-40 to 85	BU253	Samples

(1) The marketing status values are defined as follows:

ACTIVE: Product device recommended for new designs.

LIFEBUY: TI has announced that the device will be discontinued, and a lifetime-buy period is in effect.

NRND: Not recommended for new designs. Device is in production to support existing customers, but TI does not recommend using this part in a new design.

PREVIEW: Device has been announced but is not in production. Samples may or may not be available.

OBSOLETE: TI has discontinued the production of the device.

(2) **RoHS:** TI defines "RoHS" to mean semiconductor products that are compliant with the current EU RoHS requirements for all 10 RoHS substances, including the requirement that RoHS substance do not exceed 0.1% by weight in homogeneous materials. Where designed to be soldered at high temperatures, "RoHS" products are suitable for use in specified lead-free processes. TI may reference these types of products as "Pb-Free".

RoHS Exempt: TI defines "RoHS Exempt" to mean products that contain lead but are compliant with EU RoHS pursuant to a specific EU RoHS exemption.

Green: TI defines "Green" to mean the content of Chlorine (Cl) and Bromine (Br) based flame retardants meet JS709B low halogen requirements of <=1000ppm threshold. Antimony trioxide based flame retardants must also meet the <=1000ppm threshold requirement.

(3) MSL, Peak Temp. - The Moisture Sensitivity Level rating according to the JEDEC industry standard classifications, and peak solder temperature.

(4) There may be additional marking, which relates to the logo, the lot trace code information, or the environmental category on the device.

(5) Multiple Device Markings will be inside parentheses. Only one Device Marking contained in parentheses and separated by a "~" will appear on a device. If a line is indented then it is a continuation of the previous line and the two combined represent the entire Device Marking for that device.

⁽⁶⁾ Lead finish/Ball material - Orderable Devices may have multiple material finish options. Finish options are separated by a vertical ruled line. Lead finish/Ball material values may wrap to two lines if the finish value exceeds the maximum column width.

Important Information and Disclaimer:The information provided on this page represents TI's knowledge and belief as of the date that it is provided. TI bases its knowledge and belief on information provided by third parties, and makes no representation or warranty as to the accuracy of such information. Efforts are underway to better integrate information from third parties. TI has taken and continues to take reasonable steps to provide representative and accurate information but may not have conducted destructive testing or chemical analysis on incoming materials and chemicals. TI and TI suppliers consider certain information to be proprietary, and thus CAS numbers and other limited information may not be available for release.

In no event shall TI's liability arising out of such information exceed the total purchase price of the TI part(s) at issue in this document sold by TI to Customer on an annual basis.

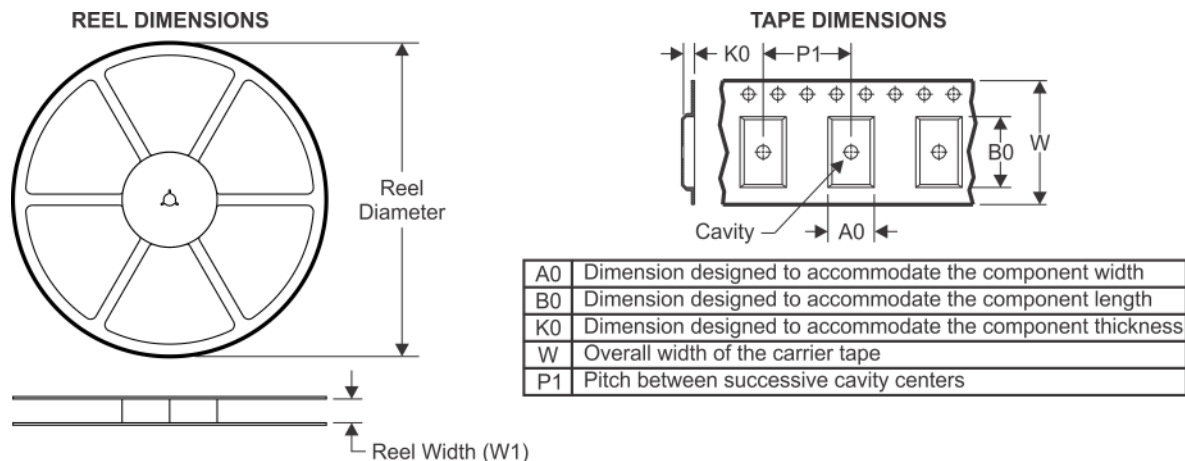
TAPE AND REEL INFORMATION

QUADRANT ASSIGNMENTS FOR PIN 1 ORIENTATION IN TAPE

*All dimensions are nominal

Device	Package Type	Package Drawing	Pins	SPQ	Reel Diameter (mm)	Reel Width W1 (mm)	A0 (mm)	B0 (mm)	K0 (mm)	P1 (mm)	W (mm)	Pin1 Quadrant
SN74CB3Q3253DBQR	SSOP	DBQ	16	2500	330.0	12.5	6.4	5.2	2.1	8.0	12.0	Q1
SN74CB3Q3253DGVR	TVSOP	DGV	16	2000	330.0	12.4	6.8	4.0	1.6	8.0	12.0	Q1
SN74CB3Q3253PWR	TSSOP	PW	16	2000	330.0	12.4	6.9	5.6	1.6	8.0	12.0	Q1
SN74CB3Q3253RGYR	VQFN	RGY	16	3000	330.0	12.4	3.8	4.3	1.5	8.0	12.0	Q1

TAPE AND REEL BOX DIMENSIONS

*All dimensions are nominal

Device	Package Type	Package Drawing	Pins	SPQ	Length (mm)	Width (mm)	Height (mm)
SN74CB3Q3253DBQR	SSOP	DBQ	16	2500	340.5	338.1	20.6
SN74CB3Q3253DGVR	TVSOP	DGV	16	2000	367.0	367.0	35.0
SN74CB3Q3253PWR	TSSOP	PW	16	2000	367.0	367.0	35.0
SN74CB3Q3253RGYR	VQFN	RGY	16	3000	367.0	367.0	35.0

TUBE

*All dimensions are nominal

Device	Package Name	Package Type	Pins	SPQ	L (mm)	W (mm)	T (μm)	B (mm)
SN74CB3Q3253PW	PW	TSSOP	16	90	530	10.2	3600	3.5

PW0016A



PACKAGE OUTLINE

TSSOP - 1.2 mm max height

SMALL OUTLINE PACKAGE

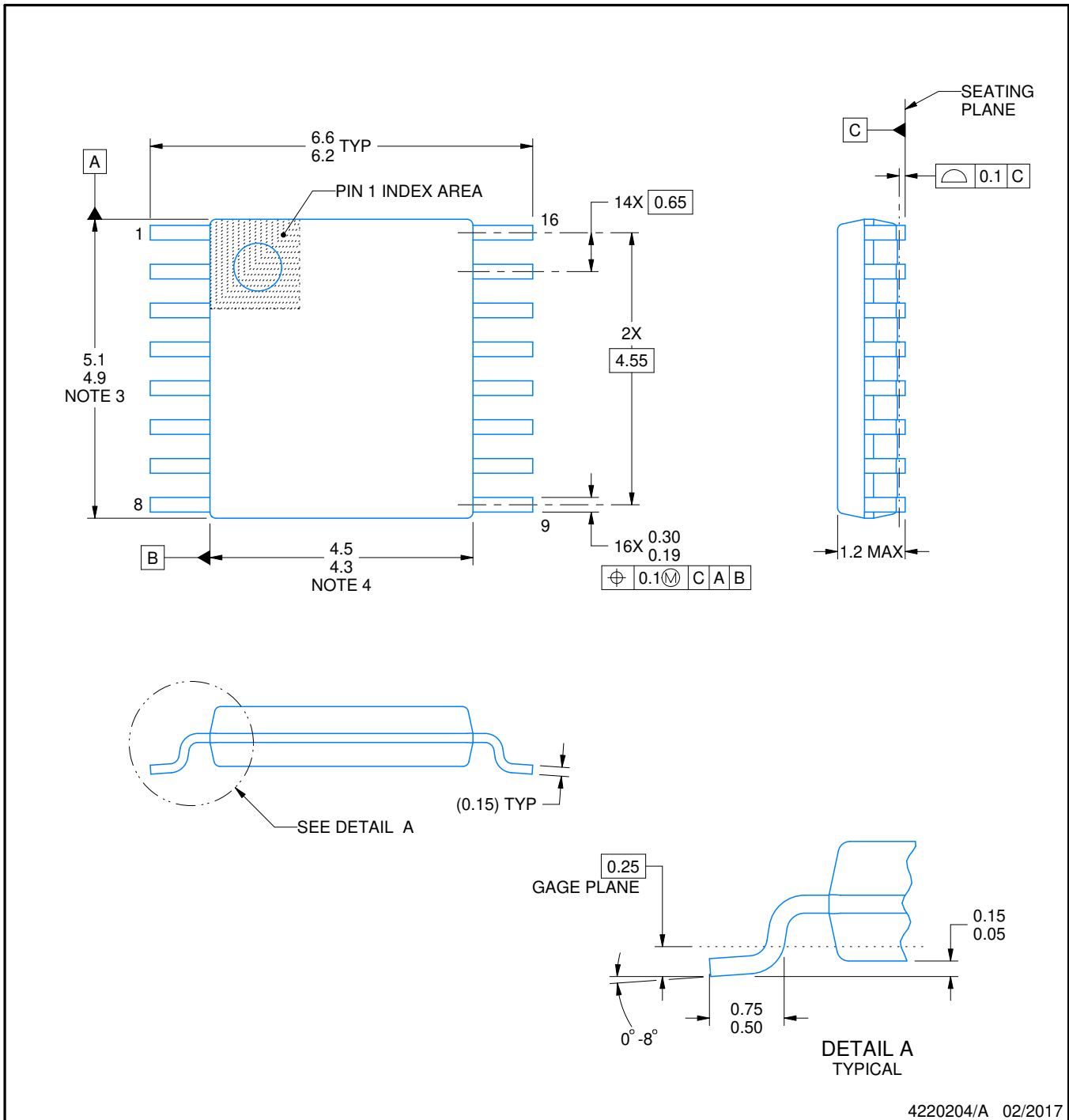

4220204/A 02/2017

NOTES:

1. All linear dimensions are in millimeters. Any dimensions in parenthesis are for reference only. Dimensioning and tolerancing per ASME Y14.5M.
2. This drawing is subject to change without notice.
3. This dimension does not include mold flash, protrusions, or gate burrs. Mold flash, protrusions, or gate burrs shall not exceed 0.15 mm per side.
4. This dimension does not include interlead flash. Interlead flash shall not exceed 0.25 mm per side.
5. Reference JEDEC registration MO-153.

EXAMPLE BOARD LAYOUT

PW0016A

TSSOP - 1.2 mm max height

SMALL OUTLINE PACKAGE

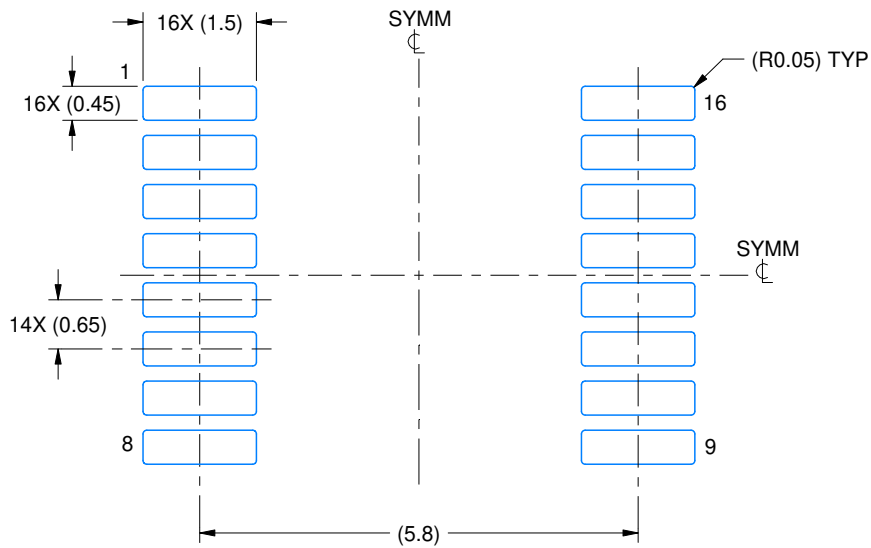

LAND PATTERN EXAMPLE
EXPOSED METAL SHOWN
SCALE: 10X

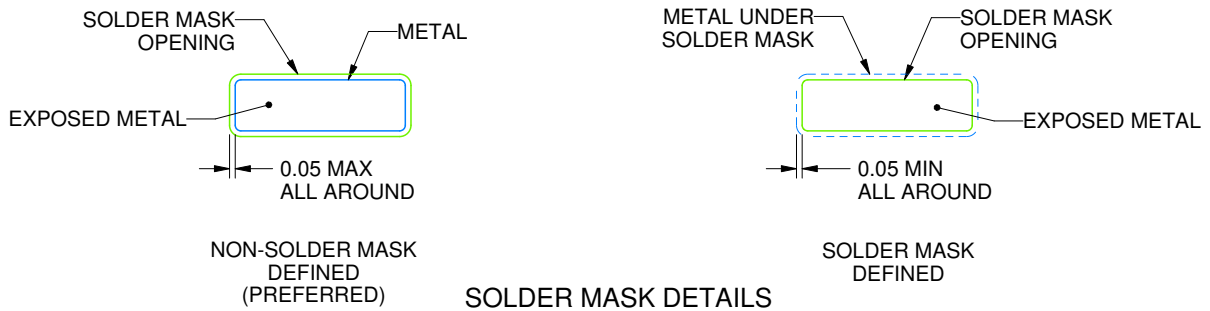

SOLDER MASK DETAILS

4220204/A 02/2017

NOTES: (continued)

- 6. Publication IPC-7351 may have alternate designs.
- 7. Solder mask tolerances between and around signal pads can vary based on board fabrication site.

EXAMPLE STENCIL DESIGN

PW0016A

TSSOP - 1.2 mm max height

SMALL OUTLINE PACKAGE

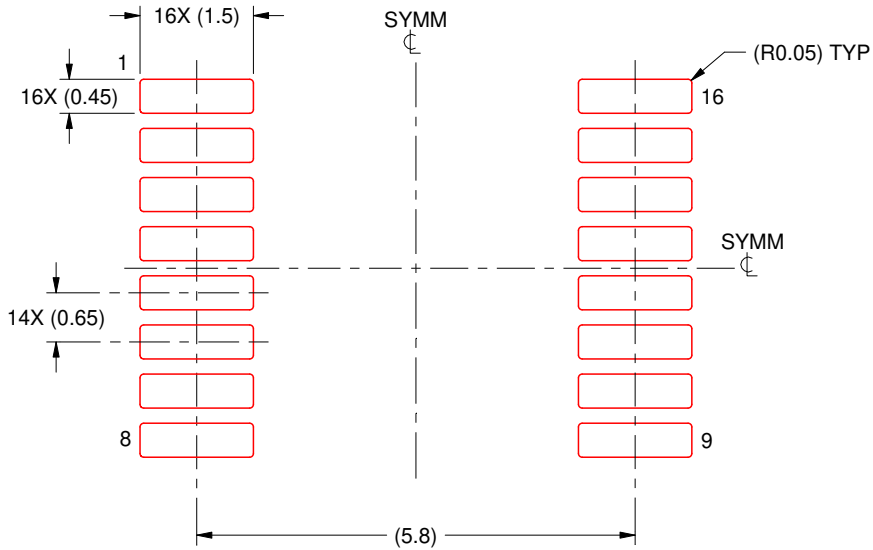

SOLDER PASTE EXAMPLE
BASED ON 0.125 mm THICK STENCIL
SCALE: 10X

4220204/A 02/2017

NOTES: (continued)

8. Laser cutting apertures with trapezoidal walls and rounded corners may offer better paste release. IPC-7525 may have alternate design recommendations.
9. Board assembly site may have different recommendations for stencil design.

DGV (R-PDSO-G**)

PLASTIC SMALL-OUTLINE

24 PINS SHOWN

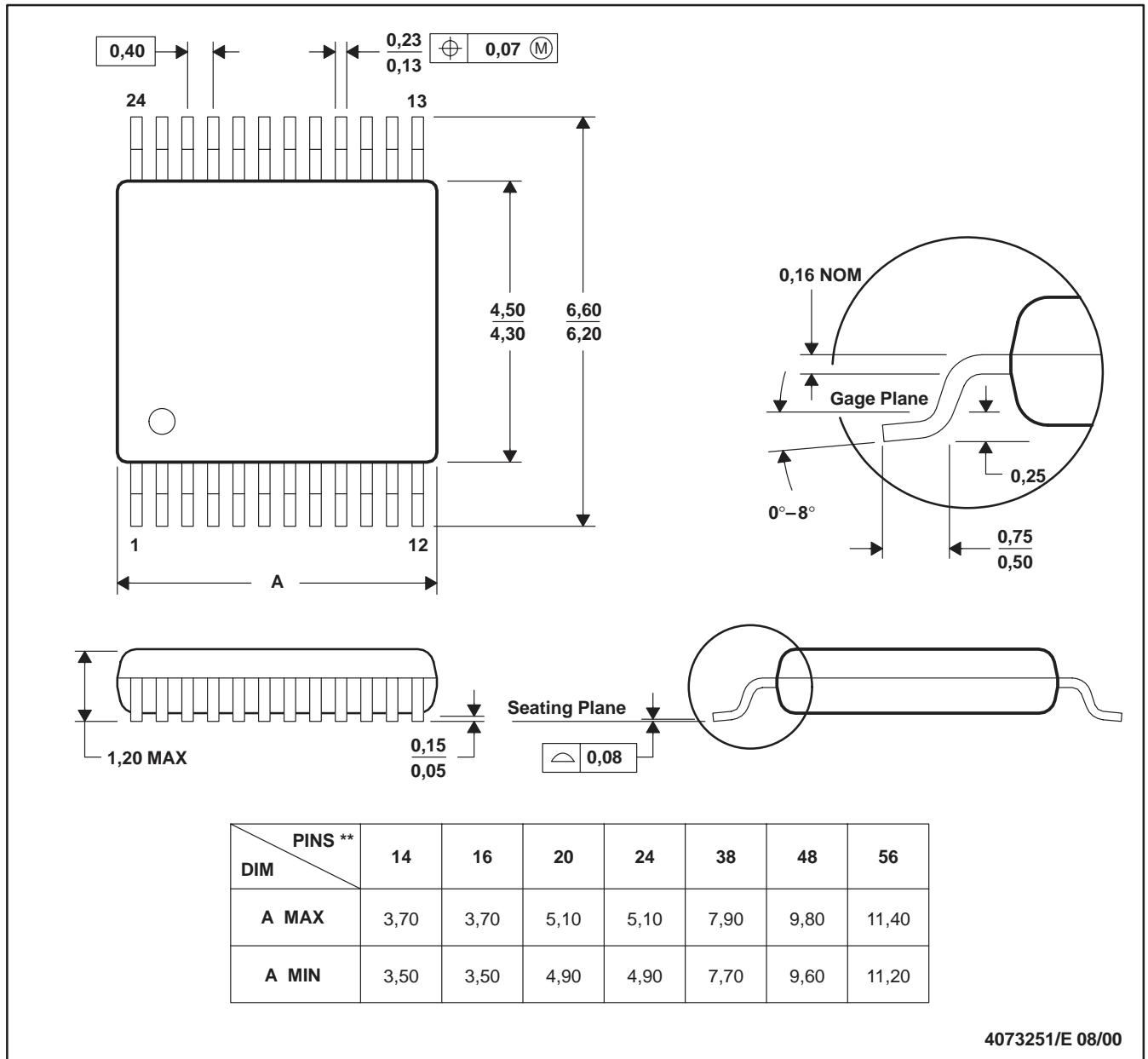

4073251/E 08/00

- NOTES: A. All linear dimensions are in millimeters.
 B. This drawing is subject to change without notice.
 C. Body dimensions do not include mold flash or protrusion, not to exceed 0,15 per side.
 D. Falls within JEDEC: 24/48 Pins – MO-153
 14/16/20/56 Pins – MO-194

EXAMPLE STENCIL DESIGN

DBQ0016A

SSOP - 1.75 mm max height

SHRINK SMALL-OUTLINE PACKAGE

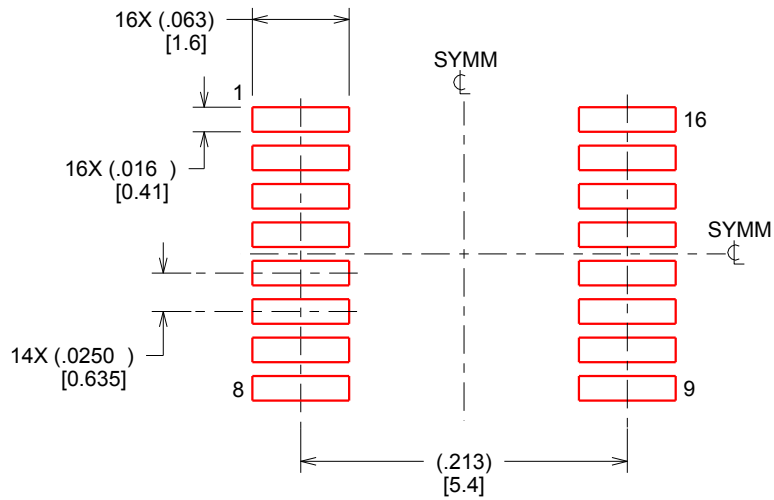

SOLDER PASTE EXAMPLE
BASED ON .005 INCH [0.127 MM] THICK STENCIL
SCALE:8X

4214846/A 03/2014

NOTES: (continued)

8. Laser cutting apertures with trapezoidal walls and rounded corners may offer better paste release. IPC-7525 may have alternate design recommendations.
9. Board assembly site may have different recommendations for stencil design.

RGY (R-PVQFN-N16)

PLASTIC QUAD FLATPACK NO-LEAD

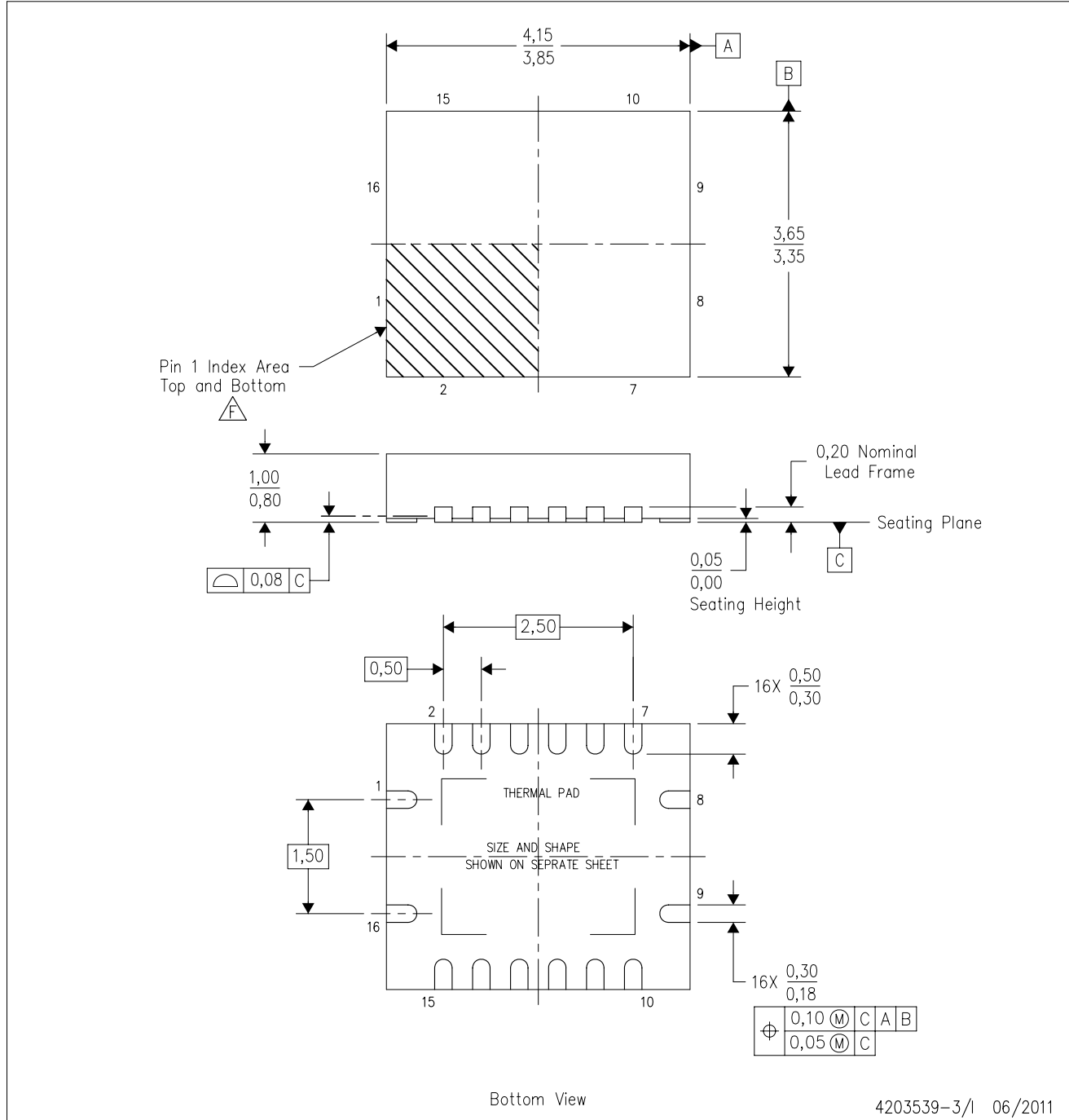

- NOTES:
- A. All linear dimensions are in millimeters. Dimensioning and tolerancing per ASME Y14.5M-1994.
 - B. This drawing is subject to change without notice.
 - C. QFN (Quad Flatpack No-Lead) package configuration.
 - D. The package thermal pad must be soldered to the board for thermal and mechanical performance.
 - E. See the additional figure in the Product Data Sheet for details regarding the exposed thermal pad features and dimensions.
 - \triangle Pin 1 identifiers are located on both top and bottom of the package and within the zone indicated. The Pin 1 identifiers are either a molded, marked, or metal feature.
 - G. Package complies to JEDEC MO-241 variation BA.

RGY (R-PVQFN-N16)

PLASTIC QUAD FLATPACK NO-LEAD

THERMAL INFORMATION

This package incorporates an exposed thermal pad that is designed to be attached directly to an external heatsink. The thermal pad must be soldered directly to the printed circuit board (PCB). After soldering, the PCB can be used as a heatsink. In addition, through the use of thermal vias, the thermal pad can be attached directly to the appropriate copper plane shown in the electrical schematic for the device, or alternatively, can be attached to a special heatsink structure designed into the PCB. This design optimizes the heat transfer from the integrated circuit (IC).

For information on the Quad Flatpack No-Lead (QFN) package and its advantages, refer to Application Report, QFN/SON PCB Attachment, Texas Instruments Literature No. SLUA271. This document is available at www.ti.com.

The exposed thermal pad dimensions for this package are shown in the following illustration.

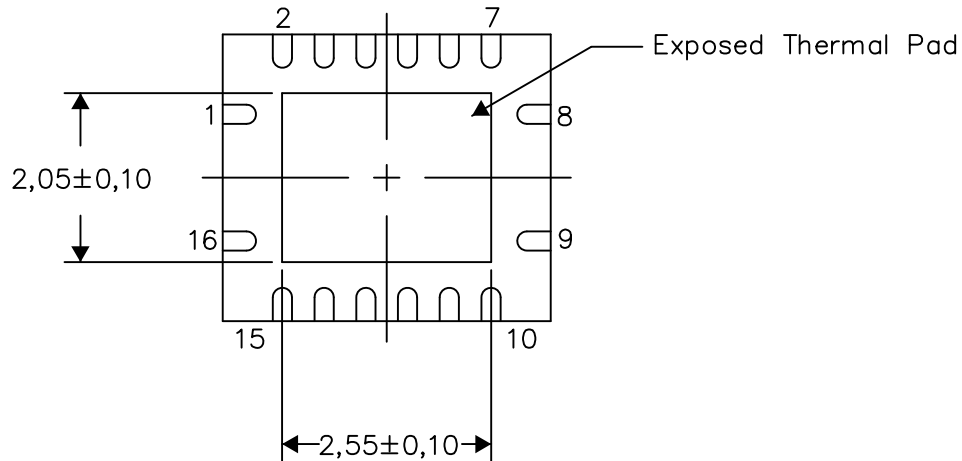

Bottom View

Exposed Thermal Pad Dimensions

4206353-3/P 03/14

NOTE: All linear dimensions are in millimeters

RGY (R-PVQFN-N16)

PLASTIC QUAD FLATPACK NO-LEAD

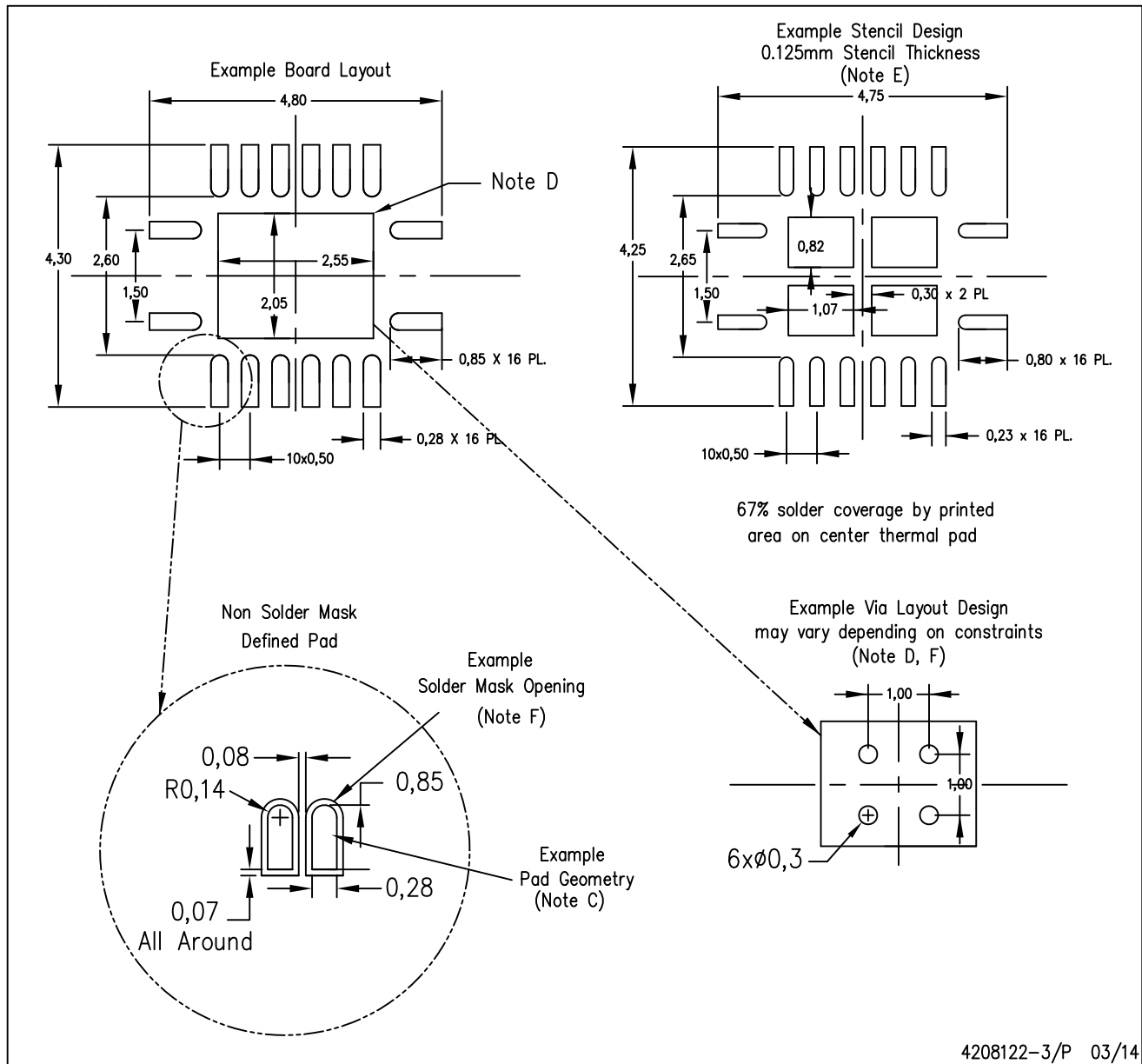

4208122-3/P 03/14

- NOTES:
- A. All linear dimensions are in millimeters.
 - B. This drawing is subject to change without notice.
 - C. Publication IPC-7351 is recommended for alternate designs.
 - D. This package is designed to be soldered to a thermal pad on the board. Refer to Application Note, Quad Flat-Pack QFN/SON PCB Attachment, Texas Instruments Literature No. SLUA271, and also the Product Data Sheets for specific thermal information, via requirements, and recommended board layout. These documents are available at www.ti.com <<http://www.ti.com>>.
 - E. Laser cutting apertures with trapezoidal walls and also rounding corners will offer better paste release. Customers should contact their board assembly site for stencil design recommendations. Refer to IPC 7525 for stencil design considerations.
 - F. Customers should contact their board fabrication site for minimum solder mask web tolerances between signal pads.

IMPORTANT NOTICE AND DISCLAIMER

TI PROVIDES TECHNICAL AND RELIABILITY DATA (INCLUDING DATA SHEETS), DESIGN RESOURCES (INCLUDING REFERENCE DESIGNS), APPLICATION OR OTHER DESIGN ADVICE, WEB TOOLS, SAFETY INFORMATION, AND OTHER RESOURCES "AS IS" AND WITH ALL FAULTS, AND DISCLAIMS ALL WARRANTIES, EXPRESS AND IMPLIED, INCLUDING WITHOUT LIMITATION ANY IMPLIED WARRANTIES OF MERCHANTABILITY, FITNESS FOR A PARTICULAR PURPOSE OR NON-INFRINGEMENT OF THIRD PARTY INTELLECTUAL PROPERTY RIGHTS.

These resources are intended for skilled developers designing with TI products. You are solely responsible for (1) selecting the appropriate TI products for your application, (2) designing, validating and testing your application, and (3) ensuring your application meets applicable standards, and any other safety, security, regulatory or other requirements.

These resources are subject to change without notice. TI grants you permission to use these resources only for development of an application that uses the TI products described in the resource. Other reproduction and display of these resources is prohibited. No license is granted to any other TI intellectual property right or to any third party intellectual property right. TI disclaims responsibility for, and you will fully indemnify TI and its representatives against, any claims, damages, costs, losses, and liabilities arising out of your use of these resources.

TI's products are provided subject to [TI's Terms of Sale](#) or other applicable terms available either on ti.com or provided in conjunction with such TI products. TI's provision of these resources does not expand or otherwise alter TI's applicable warranties or warranty disclaimers for TI products.

TI objects to and rejects any additional or different terms you may have proposed.

Mailing Address: Texas Instruments, Post Office Box 655303, Dallas, Texas 75265
Copyright © 2022, Texas Instruments Incorporated