

REVISIONS					
REV	ECO	DESCRIPTION	DATE	BY	APPR
A1	--	FIRST RELEASED	Mar.26,2017	Ben	Tommy
A2	--	UPDATE NOTES	Jul-06-2017	Nick	Tommy
A3	--	UPDATE DRAWING	Mar-21-2018	White	Tommy

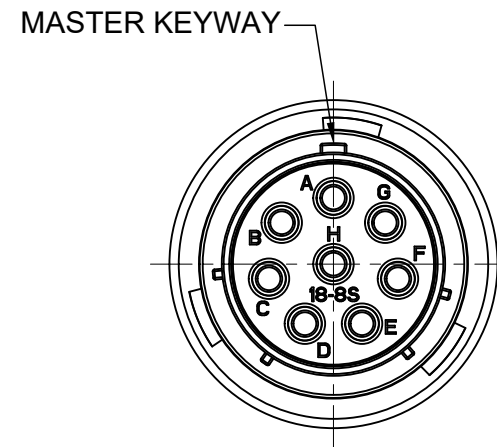

SEALING PLUGS CAN BE PURCHASED SEPARATELY

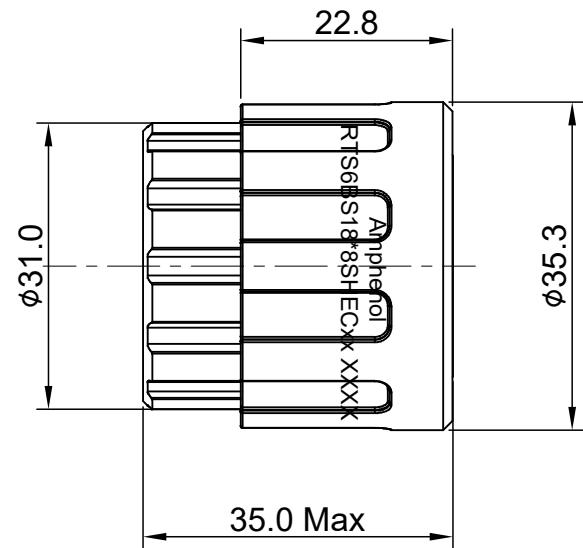
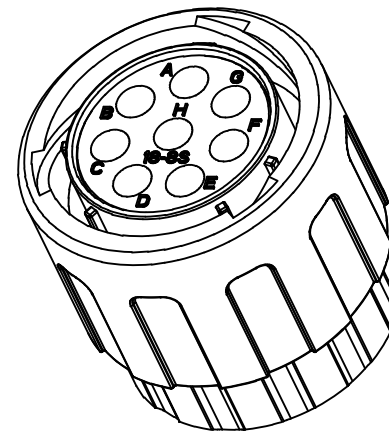
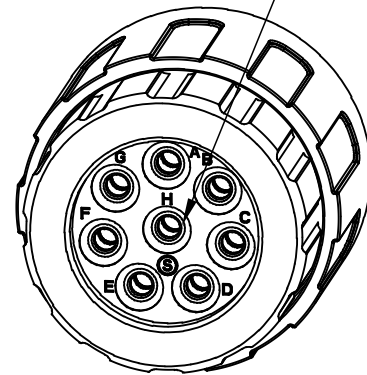

NOTES : (UNLESS OTHERWISE SPECIFIED)

- MATERIAL :
 SHELL : THERMOPLASTIC , UL94 V-0.
 INSERT : THERMOPLASTIC , UL94 V-0.
 COUPLING NUT : THERMOPLASTIC , UL94 V-0.
 O-RING : NBR OR SILICONE RUBBER.
 WASHER: SILICONE RUBBER.
 END CAP : THERMOPLASTIC , UL94 V-0.
 PLASTIC RING : THERMOPLASTIC , UL94 V-0.
 WIRE SEAL : SILICONE RUBBER.
- SPECIFICATIONS :
 2.1, RATED CURRENT : 23A (MAX).
 2.2, RATED VOLTAGE : 500V(AC/DC).
 2.3, OPERATING TEMPERATURE : SEE TABLE.
 2.4, DIELECTRIC WITHSTANDING VOLTAGE : LESS THAN 2 MILLIAMPS CURRENT LEAKAGE@2000 VOLTS AC.
 2.5, INSULATION RESISTANCE : 5000 MEGOHMS MIN.
 2.6, IP-CLASS : IP67 AND IP69K IN THE MATED CONDITION, WIRE SEALS FULLY POPULATED.
 2.7, MATING CYCLES DURABILITY : 500 CYCLES MIN.
 2.8, RoHS COMPLIANT.
- SUITABLE CONTACTS : 2.5mm CONTACT.
- ALL DIMENSIONS ARE FOR REFERENCE USE ONLY.
- CONTACT SIZE AND REAR SEAL WIRE RANGE :

CONTACT SIZE	MIN. INSUL O.D.	MAX. INSUL O.D.	WIRE RANGE
2.5MM	ø3.3MM	ø4.3MM	12 - 14AWG

KEY	PART NUMBER	
	-40°C ~ 105°C	-40°C ~ 125°C
N	RTS6BS18N8SHEC	RTS6BS18N8SHEC03

QUANTITY	PART NUMBER	DESCRIPTION	ITEM
MATERIALS LIST			
UNLESS OTHERWISE SPECIFIED 1) All dimensions are in metric(mm). 2) Tolerances are as follows: 1 PL DEC ±0.30 2 PL DEC ±0.15 3 PL DEC ±0.08 3) Note reference =		SIGNATURES DRAWN: White CHECKED: Tod ENGINEER: APPROVAL: Tommy	DATE Mar-21-2018 Mar-21-2018 Mar-21-2018
MATERIAL SPECIFICATIONS:		<div style="text-align: center;"> <h1>Amphenol</h1> <p>Sine Systems - www.amphenol-sine.com 44724 Morley Drive Clinton Township, MI 48036</p> </div>	
PROCESS SPECIFICATIONS:		CUSTOMER: THIS DRAWING IS SUPPLIED FOR INFORMATION ONLY. DESIGN FEATURES, SPECIFICATIONS AND PERFORMANCE DATA SHOWN HEREON ARE THE PROPERTY OF THE AMPHENOL CORPORATION. NO RIGHTS OF REPRODUCTION ARE IMPLIED. ALL DIMENSIONS ARE SUBJECT TO NORMAL MANUFACTURING VARIATIONS.	
NEXT ASSY:		SIZE: B TYPE: C- SCALE: NONE	DWG NO: RTS6BS18*8SHECxx REVISION: A3 SHEET 1 OF 1

TITLE: ECO-MATE,PLUG,END CAP,8POS,SOCKET CONTACT,SIZE 18
 DWG NO: RTS6BS18*8SHECxx
 REV: A3
 SH: 1
 OF: 1

ecomate® RM/RSSM/Aquarius™ - Contact Size 12 Options

Crimp Contacts, Machined				
Part Number		AWG	Wire Range (mm ²)	Plating
Male	Female			
N/A				

Tooling, Machined	
Part Number	Description
N/A	N/A
N/A	N/A

Plating Options, All	
Symbol	Plating
N/A	N/A

Crimp Contacts, Stamped & Formed				
Part Number		AWG	Wire Range (mm ²)	Plating
Male	Female			
SP12A1T	SS12A1T	14-12	2.5-3.5	Tin

Tooling, Stamped & Formed	
Part Number	Description
QXRT12S	Contact Extraction Tool, 2.5mm Contact
MFX-3962	Hand Tool, Stamped & Formed Contact, 2.5mm Contact

Misc Tooling, All	
Part Number	Description
CA-4012-59	Sealing Plug, Size 12

Standard Quantity Order Options	
Machined	Stamped & Formed
N/A	Reel, 1000 Pieces