

**SLA7031M/SLA7032M/SLA7033M**

**2-Phase/1-2 Phase Excitation**

**■ Absolute Maximum Ratings**

(T<sub>a</sub>=25°C)

Parameter	Symbol	Ratings			Unit
		SLA7031M	SLA7032M	SLA7033M	
Motor Supply Voltage	V <sub>CC</sub>	46			V
Control Supply Voltage	V <sub>S</sub>	46			V
FET Drain-Source Voltage	V <sub>DSS</sub>	100			V
Input Voltage	V <sub>IN</sub>	-0.3 to +7			V
	V <sub>SYNC</sub>	-0.3 to +7			
Reference Voltage	V <sub>REF</sub>	-0.3 to +7			V
Sense Voltage	V <sub>RS</sub>	-5 to +7			V
Output Current	I <sub>O</sub>	1	1.5	3	A
	P <sub>D1</sub>	4.5(Without Heatsink)			W
Power Dissipation	P <sub>D2</sub>	35(T <sub>c</sub> =25°C)			W
Channel Temperature	T <sub>ch</sub>	+150			°C
Operating Ambient Temperature	T <sub>a</sub>	-20 to +85			°C
Storage Temperature	T <sub>stg</sub>	-40 to +150			°C

**■ Recommended Operating Conditions**

Parameter	Symbol	Ratings		Unit	Remarks
		min.	max.		
Motor Supply Voltage	V <sub>M</sub>		44	V	
Control Supply Voltage	V <sub>S</sub>	10	44	V	
REF Input Voltage	V <sub>REF</sub>	0.1	1.0	V	The control current precision is degraded at 0.1V or lower.
	V <sub>REF(dis)</sub>	4.0	5.5	V	Output MOS FET OFF
Case Temperature	T <sub>C</sub>		100	°C	Temperature of 4(15)-Pin Lead(without heatsink)

**■ Electrical Characteristics**

Parameter	Symbol	Ratings									Unit				
		SLA7031M			SLA7032M			SLA7033M							
		min.	typ.	max.	min.	typ.	max.	min.	typ.	max.					
Control Supply Current	I <sub>S</sub>	10			15			10			15			mA	
	Condition	V <sub>S</sub> =44V													
Control Supply Voltage	V <sub>S</sub>	10	24	44	10	24	44	10	24	44	V				
FET Drain-Source Voltage	V <sub>DSS</sub>	100									V				
	Condition	V <sub>S</sub> =44V, I <sub>DSS</sub> =250μA													
FET ON Voltage	V <sub>DS</sub>				0.85						0.85			V	
	Condition	I <sub>D</sub> =1A, V <sub>S</sub> =10V													
FET Diode Forward Voltage	V <sub>SD</sub>				1.2						2.3			V	
	Condition	I <sub>SD</sub> =1A													
FET Drain Leakage Current	I <sub>DSS</sub>				250						250			μA	
	Condition	V <sub>DSS</sub> =100V, V <sub>S</sub> =44V													
IN Terminal	Input Voltage (Active High)	V <sub>IH</sub>	2.0									V			
		Condition	I <sub>D</sub> =1A												
		V <sub>IL</sub>				0.8							0.8		
	Input Voltage (Active Low)	V <sub>IH</sub>	2.0									V			
		Condition	V <sub>DSS</sub> =100V												
		V <sub>IL</sub>				0.8							0.8		
Input Current	I <sub>I</sub>				±1						±1			μA	
	Condition	V <sub>S</sub> =44V, V <sub>I</sub> =0 or 5V													
SYNC Terminal	Input Voltage	V <sub>SYNC</sub>	4.0									V			
		Condition	Synchronous chopping mode												
		V <sub>SYNC</sub>				0.8							0.8		
	Input Current	Condition	Asynchronous chopping mode									mA			
		I <sub>SYNC</sub>				0.1							0.1		
		Condition	V <sub>S</sub> =44V, V <sub>SYNC</sub> =5V												
REF Terminal	Input Current	I <sub>SYNC</sub>				-0.1						-0.1			μA
		Condition	V <sub>S</sub> =44V, V <sub>SYNC</sub> =0V												
		V <sub>REF</sub>	0			2.0			0			2.0			
	Internal Resistance	Condition	Reference Voltage input									V			
		V <sub>REF</sub>	4.0			5.5			4.0				5.5		
		Condition	Output FET OFF												
Sense Voltage	I <sub>REF</sub>				±1						±1			μA	
	Condition	No synchronous trigger													
Switching Time	R <sub>REF</sub>				40						40			Ω	
	Condition	Resistance between GND and REF terminal at synchronous trigger													
	V <sub>RS</sub>				V <sub>REF</sub>						V <sub>REF</sub>				
	T <sub>r</sub>				0.5						0.5				
	T <sub>stg</sub>				0.7						0.7				
Chopping OFF Time	T <sub>f</sub>				0.1						0.1			μs	
	Condition	V <sub>S</sub> =24V, I <sub>D</sub> =0.8A													
	T <sub>OFF</sub>				12						12				
	Condition	V <sub>S</sub> =24V													

**Internal Block Diagram**

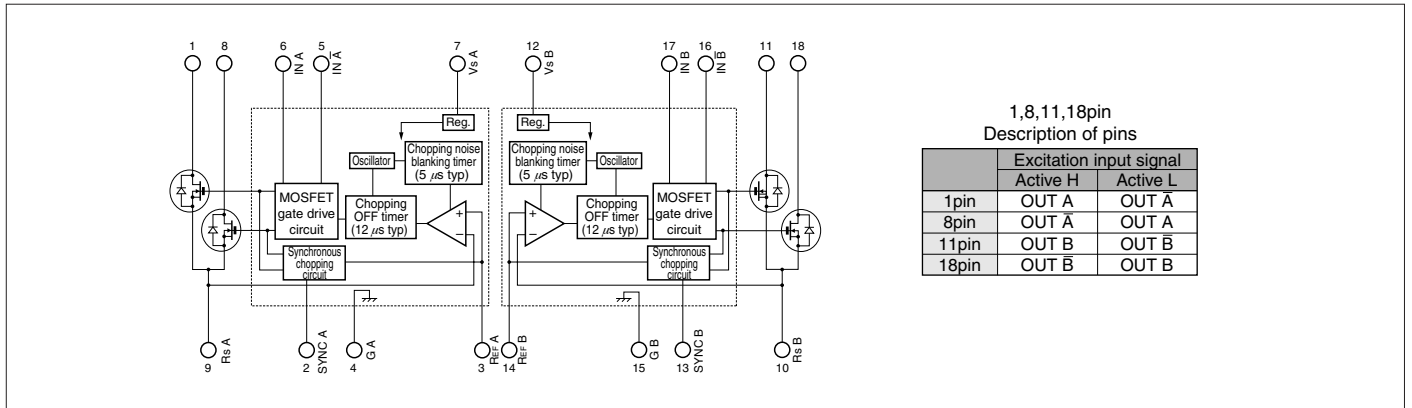

**Typical Connection Diagram (Recommended component values)**

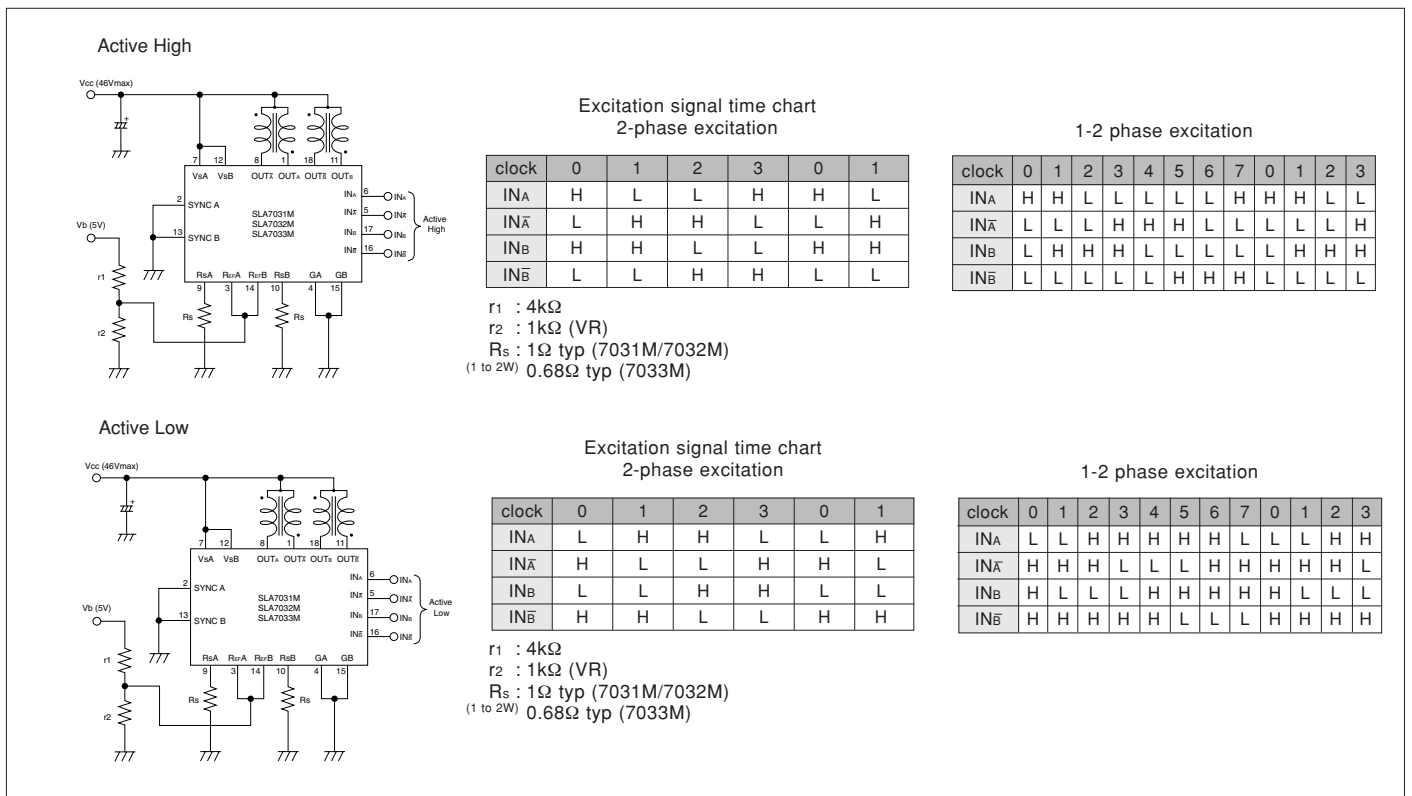

**External Dimensions (ZIP18 with Fin [SLA18Pin])**

(Unit : mm)

