

# 1.8 V/2.5 V/3.3 V Crystal Input to 1:6 LVTTL/LVCMOS Clock Fanout Buffer with OE



ON Semiconductor®

[www.onsemi.com](http://www.onsemi.com)

## NB3H83905C

### Description

The NB3H83905C is a 1.8 V, 2.5 V or 3.3 V  $V_{DD}$  core Crystal input to 1:6 LVTTL/LVCMOS fanout buffer with outputs powered by flexible 1.8 V, 2.5 V, or 3.3 V supply  $V_{DDO}$  (with  $V_{DD} \geq V_{DDO}$ ). The device accepts a fundamental Parallel Resonant crystal from 3 MHz to 40 MHz or a single-ended LVCMOS Clock from up to 100 MHz.

Two synchronous LVTTL/LVCMOS Enable lines permit independent control over outputs BCLK[0:4] and output BCLK5; enabling or disabling only when the output is in LOW state eliminating potential output glitching or runt pulse generation. When unused, leave floating open, pins will default to HIGH state.

The 6 outputs drive 50  $\Omega$  series or parallel terminated transmission lines. Parallel termination should be to  $1/2 V_{CC}$ . Series terminated lines can drive 2 loads each, or 12 lines total.

Fit, Form, and Function compatible with ICS83905 and PI6C10806.

### Features

- Six Copies of LVTTL/LVCMOS Output Clock
- Supply Operation  $V_{DD} \geq V_{DDO}$ :
  - ◆ 1.8 V  $\pm 0.2$  V, 2.5 V  $\pm 5\%$  or 3.3 V  $\pm 5\%$  Core  $V_{DD}$
  - ◆ 1.8 V  $\pm 0.2$  V, 2.5 V  $\pm 5\%$ , or 3.3 V  $\pm 5\%$  Output  $V_{DDO}$
- Crystal Oscillator Interface
- Crystal Input Frequency Range: 3 MHz to 40 MHz
- Clock Input Frequency Range: Up to 100 MHz
- LVCMOS compatible Enable Inputs
- 5 V Tolerant Enable Inputs
- Low Output to Output Skew: 80 ps Max
- Synchronous Output Enable
- Phase Noise Floor  $-160$  dBc (1 MHz)
- Industrial Temperature Range
- These are Pb-Free Devices

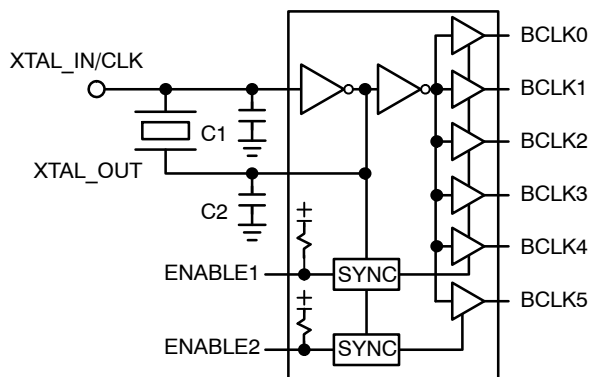
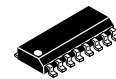
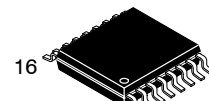

Figure 1. Simplified Block Diagram



SOIC-16  
D SUFFIX  
CASE 751B



TSSOP-16  
DT SUFFIX  
CASE 948F

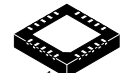

QFN20  
MN SUFFIX  
CASE 485BH

### MARKING DIAGRAMS\*

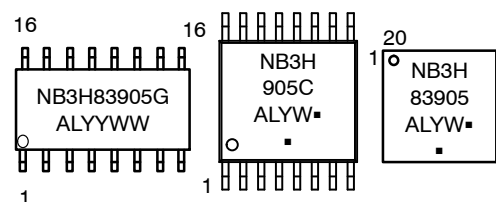

A = Assembly Location  
L = Wafer Lot  
YY, Y = Year  
WW, W = Work Week  
G or ■ = Pb-Free Package

(Note: Microdot may be in either location)

\*For additional marking information, refer to Application Note [AND8002/D](#).

### ORDERING INFORMATION

Device	Package	Shipping†
NB3H83905CDR2G	SOIC-16 (Pb-Free)	2500 / Tape & Reel
NB3H83905CDTG	TSSOP-16 (Pb-Free)	96 Units / Tube
NB3H83905CDTR2G	TSSOP-16 (Pb-Free)	2500 / Tape & Reel
NB3H83905CMNG	QFN-20 (Pb-Free)	92 Units / Tube
NB3H83905CMNTXG	QFN-20 (Pb-Free)	3000 / Tape & Reel

†For information on tape and reel specifications, including part orientation and tape sizes, please refer to our Tape and Reel Packaging Specifications Brochure, BRD8011/D.

# NB3H83905C

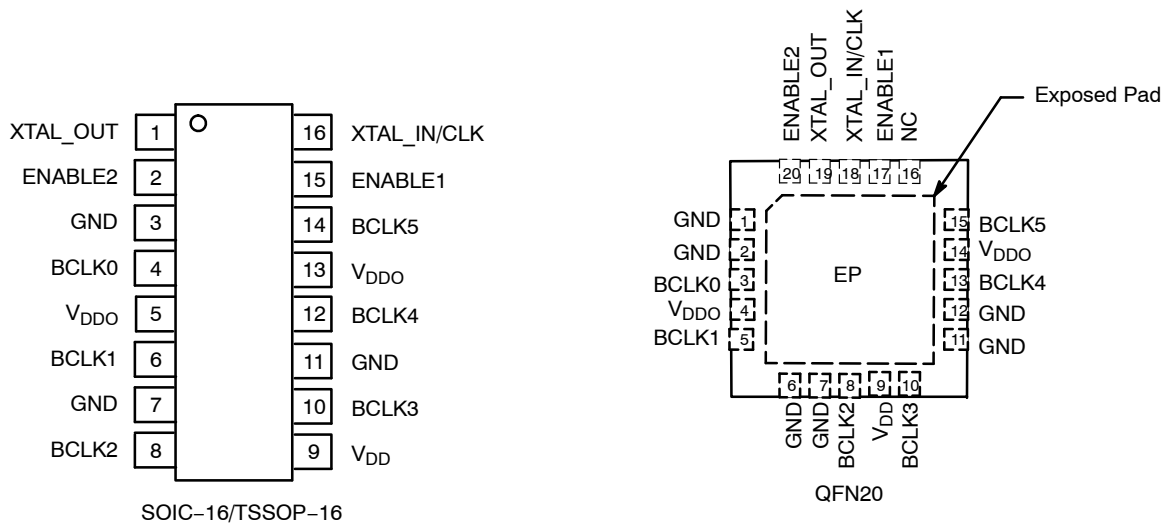

**Figure 2. Pinout Configuration (Top View)**

**Table 1. PIN DESCRIPTION**

SOIC-16 / TSSOP-16	QFN-20	Name	I/O	Description
1	19	XTAL_OUT	Crystal Interface	Oscillator Output to drive Crystal
2	20	ENABLE 2	LVTTL / LVCMOS Input	Synchronous Enable Input for BCLK5 Output. Switches only when HIGH. Open default condition HIGH due to an internal pullup resistor to V <sub>CC</sub> .
3, 7, 11	1, 2, 6, 7, 11, 12	GND	GND	GND Supply pins. All GND, V <sub>DD</sub> and V <sub>DDO</sub> pins must be externally connected to power supply to guarantee proper operation.
4, 6, 8, 10, 12, 14	3, 5, 8, 10, 13, 15	BCLK0, 1, 2, 3, 4, 5	LVCMOS Outputs	Buffered Clock Outputs
5, 13	4, 14	V <sub>DDO</sub>	POWER	Positive Supply voltage for outputs. All GND, V <sub>DD</sub> and V <sub>DDO</sub> pins must be externally connected to power supply to guarantee proper operation. Bypass with 0.01 μF cap to GND.
9	9	V <sub>DD</sub>	POWER	Positive Supply voltage for core. All GND, V <sub>DD</sub> and V <sub>DDO</sub> pins must be externally connected to power supply to guarantee proper operation. Bypass with 0.01 μF cap to GND.
-	16	NC		No Connect
15	17	ENABLE 1	LVTTL / LVCMOS Input	Synchronous Enable Input for BCLK0/1/2/3/4 Output block. Switches only when HIGH. Open default condition HIGH due to an internal pullup resistor to V <sub>CC</sub>
16	18	XTAL_IN/CLK	Crystal Interface	Oscillator Input from Crystal. Single ended Clock Input.
-	EP		-	The Exposed Pad (EP) on the QFN-20 package bottom is thermally connected to the die for improved heat transfer out of package. The exposed pad must be attached to a heat-sinking conduit. The pad is not electrically connected to the die, but is recommended to be electrically and thermally connected to GND on the PC board.

# NB3H83905C

**Table 2. CLOCK ENABLE FUNCTION TABLE**

Control Inputs		Outputs	
ENABLE1*	ENABLE2*	BCLK0:BCLK4	BCLK5
0	0	LOW	LOW
0	1	LOW	Toggling
1	0	Toggling	LOW
1	1	Toggling	Toggling

\*Defaults HIGH when floating open.

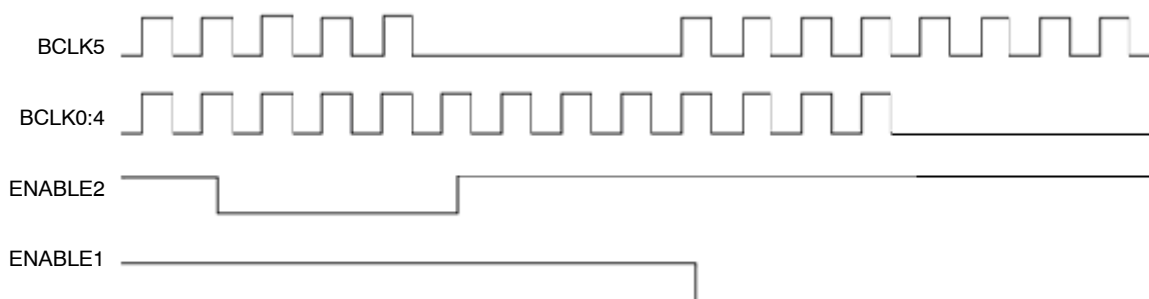

**Figure 3. ENABLEx Control Timing Diagram**

The ENABLEx control inputs will synchronously enable or disable the selected output(s). This control detects the falling edge of the internal signal and asserts or de-asserts the output after 3 clock cycles. When ENABLEx is LOW, the outputs are disabled to a LOW state. When ENABLEx is HIGH, the outputs are enabled to toggle.

**Table 3. RECOMMENDED CRYSTAL PARAMETERS**

Crystal	Fundamental AT-Cut
Frequency	10 to 40 MHz
Load Capacitance*	16–20 pF
Shunt Capacitance, C0	7 pF Max
Equivalent Series Resistance	50 Ω Max
Drive Level	1 mW

\*See APPLICATION INFORMATION; Crystal Input Interface for CL loading

**Table 4. ATTRIBUTES** (Note 1)

Characteristics	Value
ESD Protection Human Body Model Machine Model	> 2 kV > 200 V
Moisture Sensitivity, Indefinite Time Out of Drypack (Note 1)	Level 1
Flammability Rating Oxygen Index	UL-94 code V-0 A 1/8" 28 to 34
Transistor Count	213 Devices
Meets or exceeds JEDEC Spec EIA/JESD78 IC Latchup Test	

1. For additional information, see Application Note [AND8003/D](#).

# NB3H83905C

**Table 5. MAXIMUM RATINGS** (Note 2)

Symbol	Parameter	Condition 1	Condition 1	Rating	Unit
V <sub>DDx</sub>	Positive Power Supply	GND = 0 V		4.6	V
V <sub>I</sub>	Input Voltage			-0.5 ≤ V <sub>I</sub> ≤ V <sub>DD</sub> + 0.5	V
T <sub>A</sub>	Operating Temperature Range, Industrial			-40 to ≤ +85	°C
T <sub>stg</sub>	Storage Temperature Range			-65 to +150	°C
θ <sub>JA</sub>	Thermal Resistance (Junction-to-Ambient)	0 lfpm 500 lfpm	SOIC-16 SOIC-16	80 55	°C/W
θ <sub>JC</sub>	Thermal Resistance (Junction-to-Case)	(Note 3)	SOIC-16	33-36	°C/W
θ <sub>JA</sub>	Thermal Resistance (Junction-to-Ambient)	0 lfpm 500 lfpm	TSSOP-16 TSSOP-16	138 108	°C/W
θ <sub>JC</sub>	Thermal Resistance (Junction-to-Case)	(Note 3)	TSSOP-16	33-36	°C/W
θ <sub>JA</sub>	Thermal Resistance (Junction-to-Ambient)	0 lfpm 500 lfpm	QFN-20 QFN-20	47 33	°C/W
θ <sub>JC</sub>	Thermal Resistance (Junction-to-Case)	(Note 3)	QFN-20	18	°C/W
T <sub>sol</sub>	Wave Solder	3 sec @ 248°C		265	°C

Stresses exceeding those listed in the Maximum Ratings table may damage the device. If any of these limits are exceeded, device functionality should not be assumed, damage may occur and reliability may be affected.

2. Maximum ratings applied to the device are individual stress limit values (not normal operating conditions) and not valid simultaneously. If stress limits are exceeded device functional operation is not implied, damage may occur and reliability may be affected.
3. JEDEC standard multilayer board – 2S2P (2 signal, 2 power).

# NB3H83905C

**Table 6. DC CHARACTERISTICS**

Symbol	Characteristic	Min	Typ	Max	Unit
<b><math>V_{DD} = V_{DDO} = 3.135\text{ V to }3.465\text{ V (}3.3\text{ V } \pm 5\%); \text{ GND} = 0\text{ V, } T_A = -40^\circ\text{C to }+85^\circ\text{C}</math></b>					
IDD	Core Quiescent Power Supply Current (ENABLEx = LOW)			10	mA
IDDO	Output Quiescent Power Supply Current (ENABLEx = LOW)			5	mA
V <sub>IH</sub>	Input HIGH Voltage ENABLEx, XTAL_IN/CLK	2		V <sub>DD</sub> + 0.3 V	V
V <sub>IL</sub>	Input LOW Voltage ENABLEx, XTAL_IN/CLK	-0.3		0.8	V
V <sub>OH</sub>	Output HIGH Voltage (Note 4)	2.6			V
V <sub>OL</sub>	Output LOW Voltage (Note 4)			0.5	V
C <sub>IN</sub>	Input Capacitance		4		pF
C <sub>PD</sub>	Power Dissipation Capacitance (per Output) (Note 4)		19		pF
R <sub>OUT</sub>	Output Impedance (Note 4)		7		Ω
<b><math>V_{DD} = V_{DDO} = 2.375\text{ V to }2.625\text{ V (}2.5\text{ V } \pm 5\%); \text{ GND} = 0\text{ V, } T_A = -40^\circ\text{C to }+85^\circ\text{C}</math></b>					
IDD	Core Quiescent Power Supply Current (ENABLEx = LOW)			8	mA
IDDO	Output Quiescent Power Supply Current (ENABLEx = LOW)			4	mA
V <sub>IH</sub>	Input HIGH Voltage ENABLEx, XTAL_IN/CLK	1.7		V <sub>DD</sub> + 0.3 V	V
V <sub>IL</sub>	Input LOW Voltage ENABLEx, XTAL_IN/CLK	-0.3		0.7	V
V <sub>OH</sub>	Output HIGH Voltage (I <sub>OH</sub> = -1 mA) Output HIGH Voltage (Note 4)	2.0 1.8			V
V <sub>OL</sub>	Output LOW Voltage (I <sub>OL</sub> = 1 mA) Output LOW Voltage (Note 4)			0.4 0.45	V
C <sub>IN</sub>	Input Capacitance		4		pF
C <sub>PD</sub>	Power Dissipation Capacitance (per Output) (Note 4)		18		pF
R <sub>OUT</sub>	Output Impedance (Note 4)		7		Ω
<b><math>V_{DD} = V_{DDO} = 1.6\text{ V to }2.0\text{ V (}1.8\text{ V } \pm 0.2\text{ V); GND} = 0\text{ V, } T_A = -40^\circ\text{C to }+85^\circ\text{C}</math></b>					
IDD	Core Quiescent Power Supply Current (ENABLEx = LOW)			5	mA
IDDO	Output Quiescent Power Supply Current (ENABLEx = LOW)			3	mA
V <sub>IH</sub>	Input HIGH Voltage ENABLEx, XTAL_IN/CLK	0.65 * V <sub>DD</sub>		V <sub>DD</sub> + 0.3 V	V
V <sub>IL</sub>	Input LOW Voltage ENABLEx, XTAL_IN/CLK	-0.3		0.35 * V <sub>DD</sub>	V
V <sub>OH</sub>	Output HIGH Voltage (Note 4)	V <sub>DDO</sub> - 0.3			V
V <sub>OL</sub>	Output LOW Voltage (Note 4)			0.35	V
C <sub>IN</sub>	Input Capacitance		4		pF
C <sub>PD</sub>	Power Dissipation Capacitance (per Output) (Note 4)		16		pF
R <sub>OUT</sub>	Output Impedance (Note 4)		10		Ω

NOTE: Device will meet the specifications after thermal equilibrium has been established when mounted in a test socket or printed circuit board with maintained transverse airflow greater than 500 lfpm.

4. Parallel terminated 50 Ω to V<sub>DDO</sub>/2 (see Figure 5).

# NB3H83905C

**Table 6. DC CHARACTERISTICS** (continued)

Symbol	Characteristic	Min	Typ	Max	Unit
<b>V<sub>DD</sub> = 3.135 V to 3.465 V (3.3 V ±5%); V<sub>DDO</sub> = 2.375 V to 2.625 V (2.5 V ±5%); GND = 0 V, T<sub>A</sub> = -40°C to +85°C</b>					
IDD	Core Quiescent Power Supply Current (ENABLEx = LOW)			10	mA
IDDO	Output Quiescent Power Supply Current (ENABLEx = LOW)			4	mA
V <sub>IH</sub>	Input HIGH Voltage ENABLEx, XTAL_IN/CLK	2		V <sub>DD</sub> + 0.3 V	V
V <sub>IL</sub>	Input LOW Voltage ENABLEx, XTAL_IN/CLK	-0.3		0.8	V
V <sub>OH</sub>	Output HIGH Voltage (I <sub>OH</sub> = -1 mA) Output HIGH Voltage (Note 4)	2.0 1.8			V
V <sub>OL</sub>	Output LOW Voltage (I <sub>OL</sub> = 1 mA) Output LOW Voltage (Note 4)			0.4 0.45	V
C <sub>IN</sub>	Input Capacitance		4		pF
C <sub>PD</sub>	Power Dissipation Capacitance (per Output) (Note 4)		18		pF
R <sub>OUT</sub>	Output Impedance (Note 4)		7		Ω

**V<sub>DD</sub> = 3.135 V to 3.465 V (3.3 V ±5%); V<sub>DDO</sub> = 1.6 V to 2.0 V (1.8 V ±0.2 V); GND = 0 V, T<sub>A</sub> = -40°C to +85°C**

IDD	Core Quiescent Power Supply Current (ENABLEx = LOW)			10	mA
IDDO	Output Quiescent Power Supply Current (ENABLEx = LOW)			3	mA
V <sub>IH</sub>	Input HIGH Voltage ENABLEx, XTAL_IN/CLK	2		V <sub>DD</sub> + 0.3 V	V
V <sub>IL</sub>	Input LOW Voltage ENABLEx, XTAL_IN/CLK	-0.3		0.8	V
V <sub>OH</sub>	Output HIGH Voltage (Note 4)	V <sub>DDO</sub> - 0.3			V
V <sub>OL</sub>	Output LOW Voltage (Note 4)			0.35	V
C <sub>IN</sub>	Input Capacitance		4		pF
C <sub>PD</sub>	Power Dissipation Capacitance (per Output) (Note 4)		16		pF
R <sub>OUT</sub>	Output Impedance (Note 4)		10		Ω

**V<sub>DD</sub> = 2.375 V to 2.625 V (2.5 V ±5%); V<sub>DDO</sub> = 1.6 V to 2.0 V (1.8 V ±0.2 V); GND = 0 V, T<sub>A</sub> = -40°C to +85°C**

IDD	Core Quiescent Power Supply Current (ENABLEx = LOW)			8	mA
IDDO	Output Quiescent Power Supply Current (ENABLEx = LOW)			3	mA
V <sub>IH</sub>	Input HIGH Voltage ENABLEx, XTAL_IN/CLK	1.7		V <sub>DD</sub> + 0.3 V	V
V <sub>IL</sub>	Input LOW Voltage ENABLEx, XTAL_IN/CLK	-0.3		0.7	V
V <sub>OH</sub>	Output HIGH Voltage (Note 4)	V <sub>DDO</sub> - 0.3			V
V <sub>OL</sub>	Output LOW Voltage (Note 4)			0.35	V
C <sub>IN</sub>	Input Capacitance		4		pF
C <sub>PD</sub>	Power Dissipation Capacitance (per Output) (Note 4)		16		pF
R <sub>OUT</sub>	Output Impedance (Note 4)		10		Ω

NOTE: Device will meet the specifications after thermal equilibrium has been established when mounted in a test socket or printed circuit board with maintained transverse airflow greater than 500 lfm.

4. Parallel terminated 50 Ω to V<sub>DDO</sub>/2 (see Figure 5).

# NB3H83905C

**Table 7. AC CHARACTERISTICS**

Symbol	Characteristic	Min	Typ	Max	Unit
<b>V<sub>DD</sub> = V<sub>DDO</sub> = 3.135 V to 3.465 V (3.3 V ±5%); GND = 0 V, T<sub>A</sub> = -40°C to +85°C (Note 5)</b>					
F <sub>max</sub>	Input Frequency Crystal	3		40	MHz
	Input Frequency Clock (XTAL_IN/CLK)	DC		100	
t <sub>EN</sub> / t <sub>DIS</sub>	Delay for Output Enable / Disable Time ENABLEx to BCLKn			4	Cycles
tSKEW <sub>DC</sub>	Duty Cycle Skew (See Figure 4)	48		52	%
tSKEW <sub>O-O</sub>	Output to Output Skew Within A Device (same conditions)	0	50	80	ps
ΦNOISE	Phase-Noise Performance f <sub>out</sub> = 25 MHz 100 Hz off Carrier 1 kHz off Carrier 10 kHz off Carrier 100 kHz off Carrier		-123 -142 -153 -164		dBc/Hz
tJIT(Φ)	RMS Phase Jitter 25 MHz carrier, Integration Range 12 kHz to 20 MHz 25 MHz carrier, Integration Range 100 Hz to 1 MHz		0.08 0.08		ps
tr/tf	Output rise and fall times (20%; 80%)	200		800	ps

**V<sub>DD</sub> = V<sub>DDO</sub> = 2.375 V to 2.625 V (2.5 V ±5%); GND = 0 V, T<sub>A</sub> = -40°C to +85°C (Note 5)**

F <sub>max</sub>	Input Frequency Crystal	3		40	MHz
	Input Frequency Clock (XTAL1)	DC		100	
t <sub>EN</sub> / t <sub>DIS</sub>	Delay for Output Enable / Disable Time ENABLEx to BCLKn			4	Cycles
tSKEW <sub>DC</sub>	Duty Cycle Skew (See Figure 4)	47		53	%
tSKEW <sub>O-O</sub>	Output to Output Skew Within A Device (same conditions)	0	50	80	ps
ΦNOISE	Phase-Noise Performance f <sub>out</sub> = 25 MHz 100 Hz off Carrier 1 kHz off Carrier 10 kHz off Carrier 100 kHz off Carrier		-118 -137 -151 -165		dBc/Hz
tJIT(Φ)	RMS Phase Jitter 25 MHz carrier, Integration Range 12 kHz to 20 MHz 25 MHz carrier, Integration Range 100 Hz to 1 MHz		0.13 0.13		ps
tr/tf	Output rise and fall times (20%; 80%)	200		800	ps

**V<sub>DD</sub> = V<sub>DDO</sub> = 1.6 V to 2.0 V (1.8 V ±0.2 V); GND = 0 V, T<sub>A</sub> = -40°C to +85°C (Note 5)**

F <sub>max</sub>	Input Frequency Crystal	3		40	MHz
	Input Frequency Clock (XTAL1)	DC		100	
t <sub>EN</sub> / t <sub>DIS</sub>	Delay for Output Enable / Disable Time ENABLEx to BCLKn			4	Cycles
tSKEW <sub>DC</sub>	Duty Cycle Skew (See Figure 4)	47		53	%
tSKEW <sub>O-O</sub>	Output to Output Skew Within A Device (same conditions)	0	50	80	ps
ΦNOISE	Phase-Noise Performance f <sub>out</sub> = 25 MHz 100 Hz off Carrier 1 kHz off Carrier 10 kHz off Carrier 100 kHz off Carrier		-129 -145 -147 -157		dBc/Hz
tJIT(Φ)	RMS Phase Jitter 25 MHz carrier, Integration Range 12 kHz to 20 MHz 25 MHz carrier, Integration Range 100 Hz to 1 MHz		0.27 0.27		ps
tr/tf	Output rise and fall times (20%; 80%)	200		900	ps

NOTE: Device will meet the specifications after thermal equilibrium has been established when mounted in a test socket or printed circuit board with maintained transverse airflow greater than 500 lfpm.

5. Crystal inputs ≤ F<sub>max</sub>. Outputs loaded with 50 Ω to V<sub>DDO</sub>/2. CLOCK (LVCMOS levels at XTAL1 input) 50% duty cycle. See Figures 4 and 7. See APPLICATION INFORMATION; Crystal Input Interface for CL loading.

# NB3H83905C

**Table 7. AC CHARACTERISTICS** (continued)

Symbol	Characteristic	Min	Typ	Max	Unit
<b>V<sub>DD</sub> = 3.135 V to 3.465 V (3.3 V ±5%); V<sub>DDO</sub> = 2.375 V to 2.625 V (2.5 V ±5%); GND = 0 V, T<sub>A</sub> = -40°C to +85°C (Note 5)</b>					
F <sub>max</sub>	Input Frequency Crystal	3		40	MHz
	Input Frequency Clock (XTAL_IN/CLK)	DC		100	
t <sub>EN</sub> / t <sub>DIS</sub>	Delay for Output Enable / Disable Time ENABLEx to BCLKn			4	Cycles
tSKEW <sub>DC</sub>	Duty Cycle Skew (See Figure 4)	48		52	%
tSKEW <sub>O-O</sub>	Output to Output Skew Within A Device (same conditions)	0	50	80	ps
ΦNOISE	Phase-Noise Performance f <sub>out</sub> = 25 MHz 100 Hz off Carrier 1 kHz off Carrier 10 kHz off Carrier 100 kHz off Carrier		-129 -145 -147 -157		dBc/Hz
tJIT(Φ)	RMS Phase Jitter 25 MHz carrier, Integration Range 12 kHz to 20 MHz 25 MHz carrier, Integration Range 100 Hz to 1 MHz		0.14 0.14		ps
tr/tf	Output rise and fall times (20%; 80%)	200		800	ps

**V<sub>DD</sub> = 3.135 V to 3.465 V (3.3 V ±5%); V<sub>DDO</sub> = 1.6 V to 2.0 V (1.8 V ±0.2 V); GND = 0 V, T<sub>A</sub> = -40°C to +85°C (Note 5)**

F <sub>max</sub>	Input Frequency Crystal	3		40	MHz
	Input Frequency Clock (XTAL1)	DC		100	
t <sub>EN</sub> / t <sub>DIS</sub>	Delay for Output Enable / Disable Time ENABLEx to BCLKn			4	Cycles
tSKEW <sub>DC</sub>	Duty Cycle Skew (See Figure 4)	48		52	%
tSKEW <sub>O-O</sub>	Output to Output Skew Within A Device (same conditions)	0	50	80	ps
ΦNOISE	Phase-Noise Performance f <sub>out</sub> = 25 MHz 100 Hz off Carrier 1 kHz off Carrier 10 kHz off Carrier 100 kHz off Carrier		-129 -145 -147 -157		dBc/Hz
tJIT(Φ)	RMS Phase Jitter 25 MHz carrier, Integration Range 12 kHz to 20 MHz 25 MHz carrier, Integration Range 100 Hz to 1 MHz		0.18 0.18		ps
tr/tf	Output rise and fall times (20%; 80%)	200		900	ps

**V<sub>DD</sub> = 2.375 V to 2.625 V (2.5 V ±5%); V<sub>DDO</sub> = 1.6 V to 2.0 V (1.8 V ±0.2 V); GND = 0 V, T<sub>A</sub> = -40°C to +85°C (Note 5)**

F <sub>max</sub>	Input Frequency Crystal	3		40	MHz
	Input Frequency Clock (XTAL1)	DC		100	
t <sub>EN</sub> / t <sub>DIS</sub>	Delay for Output Enable / Disable Time ENABLEx to BCLKn			4	Cycles
tSKEW <sub>DC</sub>	Duty Cycle Skew (See Figure 4)	47		53	%
tSKEW <sub>O-O</sub>	Output to Output Skew Within A Device (same conditions)	0	50	80	ps
ΦNOISE	Phase-Noise Performance f <sub>out</sub> = 25 MHz/ 100 Hz off Carrier 1 kHz off Carrier 10 kHz off Carrier 100 kHz off Carrier		-129 -145 -147 -157		dBc/Hz
tJIT(Φ)	RMS Phase Jitter 25 MHz carrier, Integration Range 12 kHz to 20 MHz 25 MHz carrier, Integration Range 100 Hz to 1 MHz		0.19 0.19		ps
tr/tf	Output rise and fall times (20%; 80%)	200		900	ps

NOTE: Device will meet the specifications after thermal equilibrium has been established when mounted in a test socket or printed circuit board with maintained transverse airflow greater than 500 lfpm.

5. Crystal inputs ≤ F<sub>max</sub>. Outputs loaded with 50 Ω to V<sub>DDO</sub>/2. CLOCK (LVCMOS levels at XTAL1 input) 50% duty cycle. See Figures 4 and 7. See APPLICATION INFORMATION; Crystal Input Interface for CL loading.



# NB3H83905C

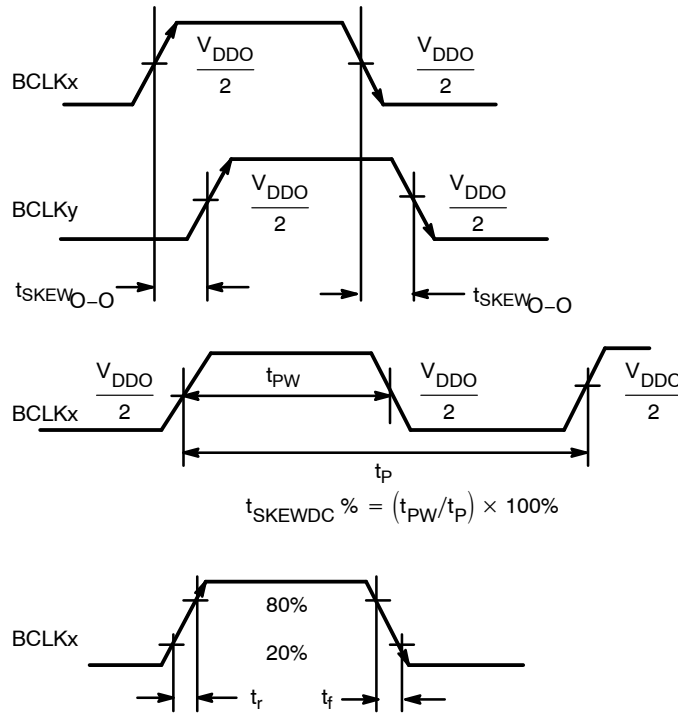

Figure 4. AC Reference Measurement

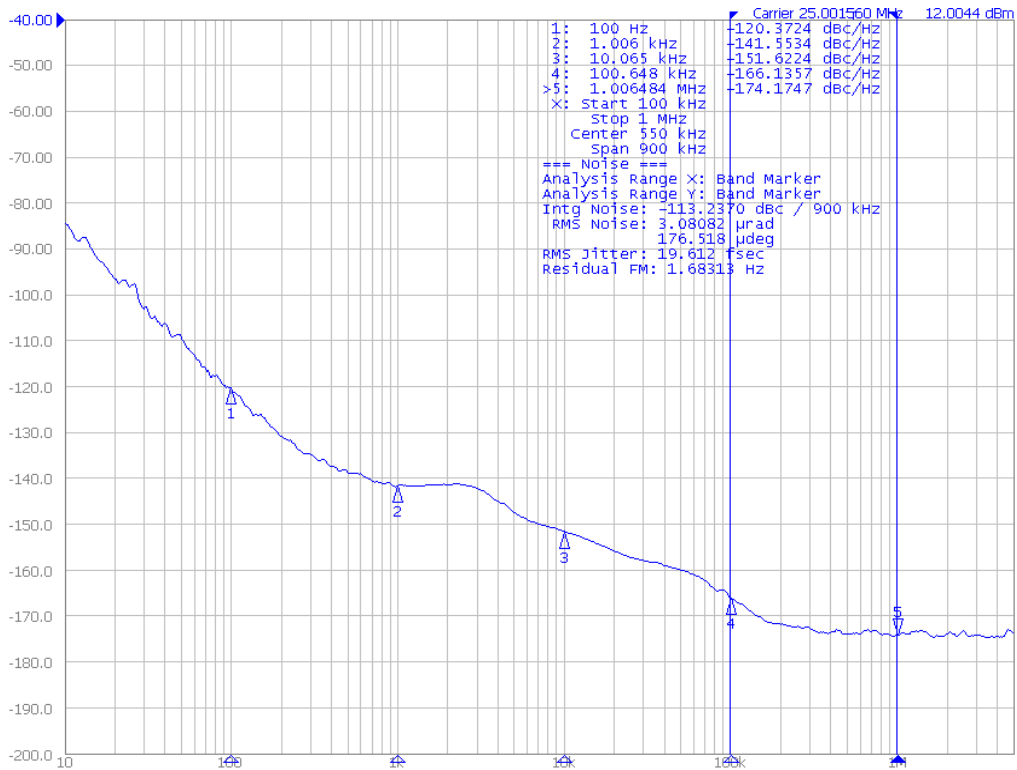

Figure 5. Typical Phase Noise Plot of the NB3H83905C Operating at 25 MHz  $V_{DD} = V_{DDO} = 3.3$  V

# NB3H83905C

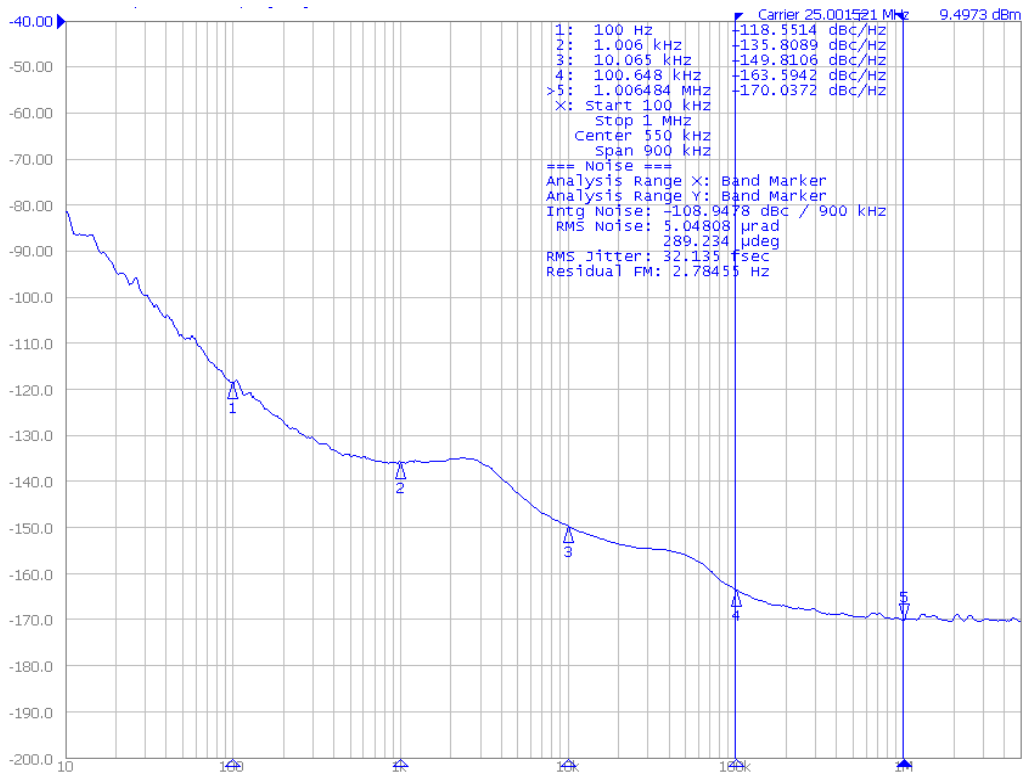

Figure 6. Typical Phase Noise Plot of the NB3H83905C Operating at 25 MHz  $V_{DD} = V_{DDO} = 2.5$  V

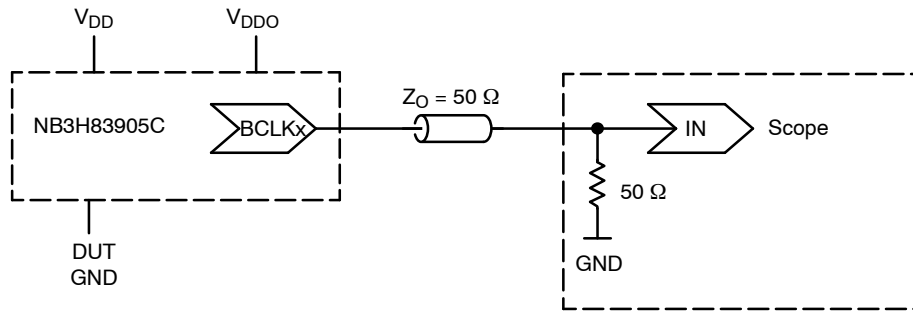

Figure 7. Typical Device Evaluation and Termination Setup – See Table 8

Table 8. TEST SUPPLY SETUP.  $V_{DDO}$  SUPPLY MAY BE CENTERED ON 0.0 V (SCOPE GND) TO PERMIT DIRECT CONNECTION INTO “50  $\Omega$  TO GND” SCOPE MODULE.  $V_{DD}$  SUPPLY TRACKS DUT GND PIN

Spec Condition:	Test Setup $V_{DD}$ :	Test Setup $V_{DDO}$ :	Test Setup DUT GND:
$V_{DD} = V_{DDO} = 3.135$ V to $3.465$ V ( $3.3$ V $\pm$ 5%)	1.56 to 1.73 V	1.56 to 1.73 V	-1.56 to -1.73 V
$V_{DD} = V_{DDO} = 2.375$ V to $2.625$ V ( $2.5$ V $\pm$ 5%)	1.1875 to 1.3125 V	1.1875 to 1.3125 V	-1.1875 to -1.3125 V
$V_{DD} = V_{DDO} = 1.6$ V to $2.0$ V ( $1.8$ V $\pm$ 0.2 V)	0.8 to 1.0 V	0.8 to 1.0 V	-0.8 to -1.0 V
$V_{DD} = 3.135$ V to $3.465$ V ( $3.3$ V $\pm$ 5%); $V_{DDO} = 2.375$ V to $2.625$ V ( $2.5$ V $\pm$ 5%)	1.955 to 2.1525 V	1.1875 to 1.3125 V	-1.1875 to -1.3125 V
$V_{DD} = 3.135$ V to $3.465$ V ( $3.3$ V $\pm$ 5%); $V_{DDO} = 1.6$ V to $2.0$ V ( $1.8$ V $\pm$ 0.2 V)	2.335 to 2.465 V	0.8 to 1.0 V	-0.8 to -1.0 V
$V_{DD} = 2.375$ V to $2.625$ V ( $2.5$ V $\pm$ 5%); $V_{DDO} = 1.6$ V to $2.0$ V ( $1.8$ V $\pm$ 0.2 V)	1.575 to 1.625 V	0.8 to 1.0 V	-0.8 to -1.0 V

APPLICATION INFORMATION

**Crystal Input Interface**

Figure 8 shows the NB3H83905C device crystal oscillator interface using a typical parallel resonant crystal. A parallel crystal with loading capacitance  $C_L = 18 \text{ pF}$  would use  $C1 = 32 \text{ pF}$  and  $C2 = 32 \text{ pF}$  as nominal values, assuming  $4 \text{ pF}$  of stray cap per line. The frequency accuracy and duty cycle skew can be fine tuned by adjusting the  $C1$  and  $C2$  values. For example, increasing the  $C1$  and  $C2$  values will reduce the operational frequency. Note  $R1$  is optional and may be  $0 \Omega$ .

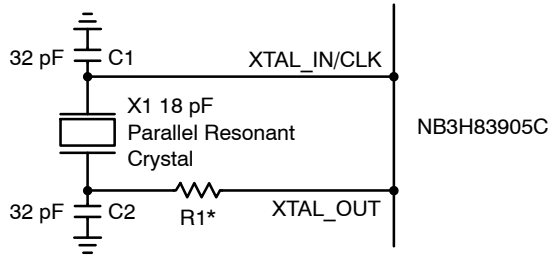

**Figure 8. NB3H83905C Crystal Oscillator Interface**  
\* R1 is optional

**Termination**

NB3H83905C device output series termination may be used by locating a  $28 \Omega$  series resistor at the driver pin as shown in Figure 9. Alternatively, a Thevenin Parallel termination may be used by locating a  $100 \Omega$  pullup resistor to  $V_{DD}$  and a  $100 \Omega$  pullup resistor to GND at the receiver pin, instead of an  $R_s$  source termination resistor, Figure 10.

**Unused Input and Output Pins**

All LVCMOS control pins have internal pull-ups or pull-downs; additional external resistors are not required (optionally  $1 \text{ k}\Omega$  resistors may be used). All unused LVCMOS outputs can be left floating with no trace attached.

**Bypass**

The  $V_{DD}$  and  $V_{DDO}$  supply pins should be bypassed with both a  $10 \mu\text{F}$  and a  $0.1 \mu\text{F}$  cap from supply pins to GND.

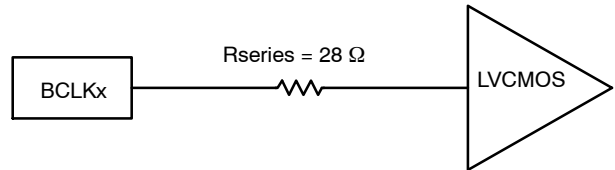

**Figure 9. Series Termination**

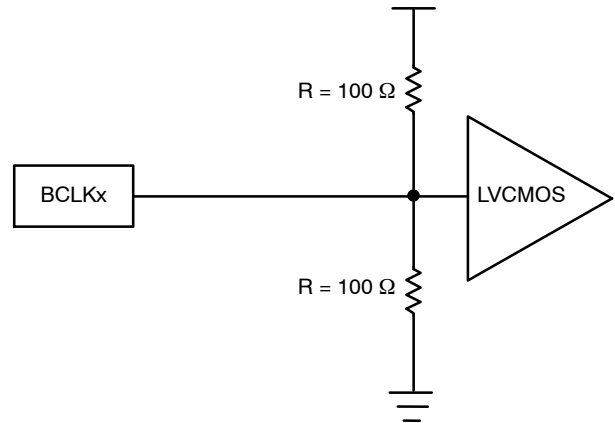

**Figure 10. Optional Thevenin Termination**

# MECHANICAL CASE OUTLINE PACKAGE DIMENSIONS

ON Semiconductor®

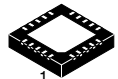

SCALE 2:1

QFN20 4x4, 0.5P  
CASE 485BH-01  
ISSUE O

DATE 19 FEB 2010

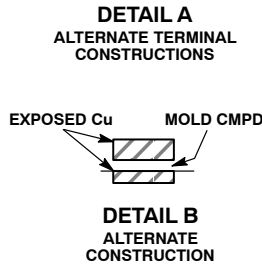
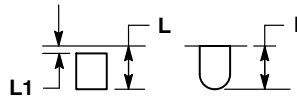
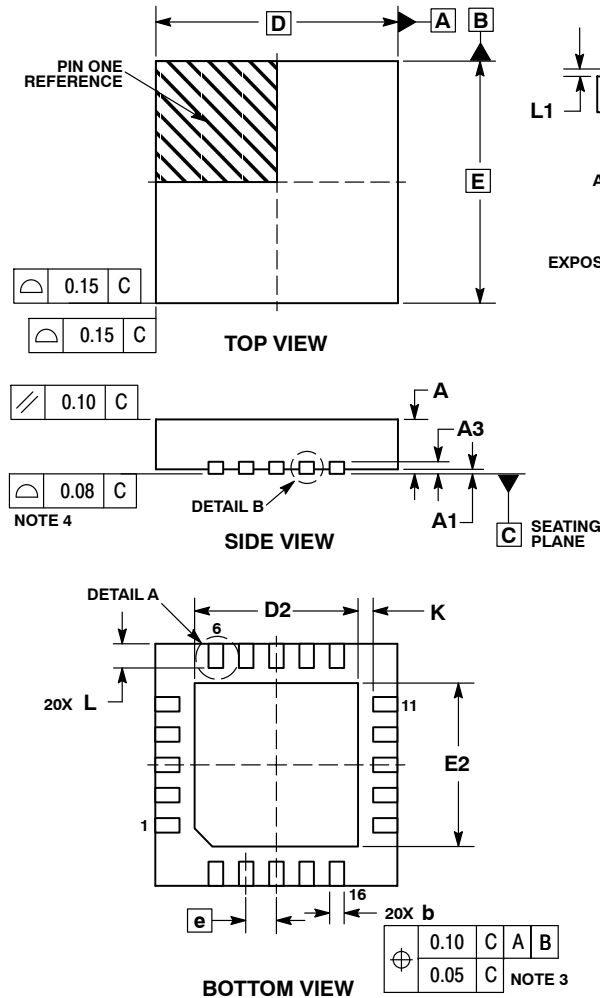

NOTES:

1. DIMENSIONING AND TOLERANCING PER ASME Y14.5M, 1994.
2. CONTROLLING DIMENSION: MILLIMETERS.
3. DIMENSION b APPLIES TO PLATED TERMINAL AND IS MEASURED BETWEEN 0.15 AND 0.30 MM FROM TERMINAL TIP.
4. COPLANARITY APPLIES TO THE EXPOSED PAD AS WELL AS THE TERMINALS.

DIM	MILLIMETERS	
	MIN	MAX
A	0.80	1.00
A1	---	0.05
A3	0.20	REF
b	0.20	0.30
D	4.00	BSC
D2	2.60	2.80
E	4.00	BSC
E2	2.60	2.80
e	0.50	BSC
K	0.20	---
L	0.35	0.45
L1	0.00	0.15

GENERIC MARKING DIAGRAM\*

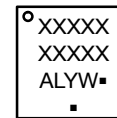

- XXXXX = Specific Device Code
- A = Assembly Location
- L = Wafer Lot
- Y = Year
- W = Work Week
- = Pb-Free Package

(Note: Microdot may be in either location)

\*This information is generic. Please refer to device data sheet for actual part marking. Pb-Free indicator, "G", may or not be present.

MOUNTING FOOTPRINT

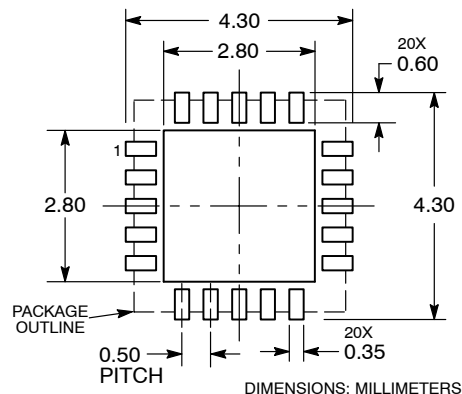

DOCUMENT NUMBER:	98AON48317E	Electronic versions are uncontrolled except when accessed directly from the Document Repository. Printed versions are uncontrolled except when stamped "CONTROLLED COPY" in red.
DESCRIPTION:	QFN20 4X4, 0.5P	PAGE 1 OF 1

ON Semiconductor and ON are trademarks of Semiconductor Components Industries, LLC dba ON Semiconductor or its subsidiaries in the United States and/or other countries. ON Semiconductor reserves the right to make changes without further notice to any products herein. ON Semiconductor makes no warranty, representation or guarantee regarding the suitability of its products for any particular purpose, nor does ON Semiconductor assume any liability arising out of the application or use of any product or circuit, and specifically disclaims any and all liability, including without limitation special, consequential or incidental damages. ON Semiconductor does not convey any license under its patent rights nor the rights of others.

# MECHANICAL CASE OUTLINE PACKAGE DIMENSIONS

ON Semiconductor®

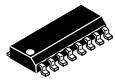

SCALE 1:1

## SOIC-16 CASE 751B-05 ISSUE K

DATE 29 DEC 2006

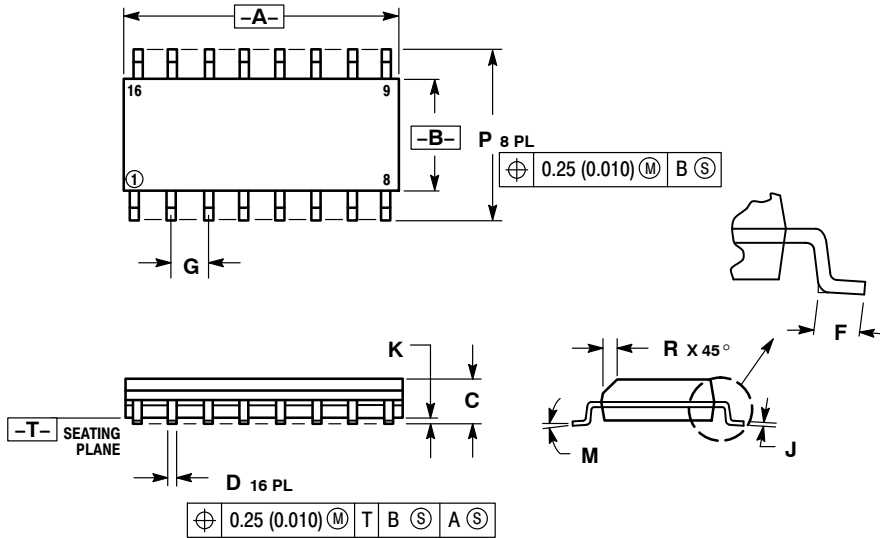

NOTES:

1. DIMENSIONING AND TOLERANCING PER ANSI Y14.5M, 1982.
2. CONTROLLING DIMENSION: MILLIMETER.
3. DIMENSIONS A AND B DO NOT INCLUDE MOLD PROTRUSION.
4. MAXIMUM MOLD PROTRUSION 0.15 (0.006) PER SIDE.
5. DIMENSION D DOES NOT INCLUDE DAMBAR PROTRUSION. ALLOWABLE DAMBAR PROTRUSION SHALL BE 0.127 (0.005) TOTAL IN EXCESS OF THE D DIMENSION AT MAXIMUM MATERIAL CONDITION.

DIM	MILLIMETERS		INCHES	
	MIN	MAX	MIN	MAX
A	9.80	10.00	0.386	0.393
B	3.80	4.00	0.150	0.157
C	1.35	1.75	0.054	0.068
D	0.35	0.49	0.014	0.019
F	0.40	1.25	0.016	0.049
G	1.27 BSC		0.050 BSC	
J	0.19	0.25	0.008	0.009
K	0.10	0.25	0.004	0.009
M	0°	7°	0°	7°
P	5.80	6.20	0.229	0.244
R	0.25	0.50	0.010	0.019

- |  |  |  |  |
|--|--|--|--|
| <p>STYLE 1:</p> <p>PIN 1. COLLECTOR</p> <p>2. BASE</p> <p>3. EMITTER</p> <p>4. NO CONNECTION</p> <p>5. EMITTER</p> <p>6. BASE</p> <p>7. COLLECTOR</p> <p>8. COLLECTOR</p> <p>9. BASE</p> <p>10. EMITTER</p> <p>11. NO CONNECTION</p> <p>12. EMITTER</p> <p>13. BASE</p> <p>14. COLLECTOR</p> <p>15. EMITTER</p> <p>16. COLLECTOR</p>                           | <p>STYLE 2:</p> <p>PIN 1. CATHODE</p> <p>2. ANODE</p> <p>3. NO CONNECTION</p> <p>4. CATHODE</p> <p>5. CATHODE</p> <p>6. NO CONNECTION</p> <p>7. ANODE</p> <p>8. CATHODE</p> <p>9. CATHODE</p> <p>10. ANODE</p> <p>11. NO CONNECTION</p> <p>12. CATHODE</p> <p>13. CATHODE</p> <p>14. NO CONNECTION</p> <p>15. ANODE</p> <p>16. CATHODE</p> | <p>STYLE 3:</p> <p>PIN 1. COLLECTOR, DYE #1</p> <p>2. BASE, #1</p> <p>3. EMITTER, #1</p> <p>4. COLLECTOR, #1</p> <p>5. COLLECTOR, #2</p> <p>6. BASE, #2</p> <p>7. EMITTER, #2</p> <p>8. COLLECTOR, #2</p> <p>9. COLLECTOR, #3</p> <p>10. BASE, #3</p> <p>11. EMITTER, #3</p> <p>12. COLLECTOR, #3</p> <p>13. COLLECTOR, #4</p> <p>14. BASE, #4</p> <p>15. EMITTER, #4</p> <p>16. COLLECTOR, #4</p>   | <p>STYLE 4:</p> <p>PIN 1. COLLECTOR, DYE #1</p> <p>2. COLLECTOR, #1</p> <p>3. COLLECTOR, #2</p> <p>4. COLLECTOR, #2</p> <p>5. COLLECTOR, #3</p> <p>6. COLLECTOR, #3</p> <p>7. COLLECTOR, #4</p> <p>8. COLLECTOR, #4</p> <p>9. BASE, #4</p> <p>10. EMITTER, #4</p> <p>11. BASE, #3</p> <p>12. EMITTER, #3</p> <p>13. BASE, #2</p> <p>14. EMITTER, #2</p> <p>15. BASE, #1</p> <p>16. EMITTER, #1</p> |
| <p>STYLE 5:</p> <p>PIN 1. DRAIN, DYE #1</p> <p>2. DRAIN, #1</p> <p>3. DRAIN, #2</p> <p>4. DRAIN, #2</p> <p>5. DRAIN, #3</p> <p>6. DRAIN, #3</p> <p>7. DRAIN, #4</p> <p>8. DRAIN, #4</p> <p>9. GATE, #4</p> <p>10. SOURCE, #4</p> <p>11. GATE, #3</p> <p>12. SOURCE, #3</p> <p>13. GATE, #2</p> <p>14. SOURCE, #2</p> <p>15. GATE, #1</p> <p>16. SOURCE, #1</p> | <p>STYLE 6:</p> <p>PIN 1. CATHODE</p> <p>2. CATHODE</p> <p>3. CATHODE</p> <p>4. CATHODE</p> <p>5. CATHODE</p> <p>6. CATHODE</p> <p>7. CATHODE</p> <p>8. CATHODE</p> <p>9. ANODE</p> <p>10. ANODE</p> <p>11. ANODE</p> <p>12. ANODE</p> <p>13. ANODE</p> <p>14. ANODE</p> <p>15. ANODE</p> <p>16. ANODE</p>                                 | <p>STYLE 7:</p> <p>PIN 1. SOURCE N-CH</p> <p>2. COMMON DRAIN (OUTPUT)</p> <p>3. COMMON DRAIN (OUTPUT)</p> <p>4. GATE P-CH</p> <p>5. COMMON DRAIN (OUTPUT)</p> <p>6. COMMON DRAIN (OUTPUT)</p> <p>7. COMMON DRAIN (OUTPUT)</p> <p>8. SOURCE P-CH</p> <p>9. SOURCE P-CH</p> <p>10. COMMON DRAIN (OUTPUT)</p> <p>11. COMMON DRAIN (OUTPUT)</p> <p>12. COMMON DRAIN (OUTPUT)</p> <p>13. GATE N-CH</p> <p>14. COMMON DRAIN (OUTPUT)</p> <p>15. COMMON DRAIN (OUTPUT)</p> <p>16. SOURCE N-CH</p> |  |

### SOLDERING FOOTPRINT

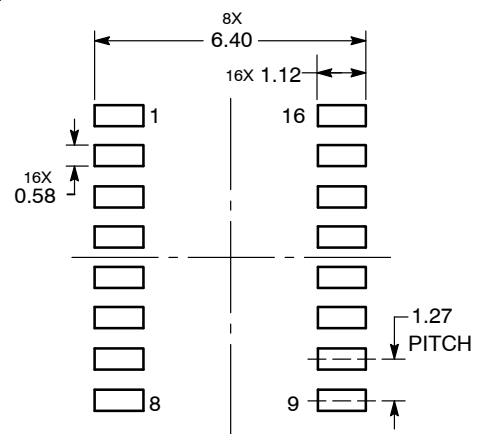

DIMENSIONS: MILLIMETERS

DOCUMENT NUMBER:	98ASB42566B	Electronic versions are uncontrolled except when accessed directly from the Document Repository. Printed versions are uncontrolled except when stamped "CONTROLLED COPY" in red.
DESCRIPTION:	SOIC-16	PAGE 1 OF 1

ON Semiconductor and ON are trademarks of Semiconductor Components Industries, LLC dba ON Semiconductor or its subsidiaries in the United States and/or other countries. ON Semiconductor reserves the right to make changes without further notice to any products herein. ON Semiconductor makes no warranty, representation or guarantee regarding the suitability of its products for any particular purpose, nor does ON Semiconductor assume any liability arising out of the application or use of any product or circuit, and specifically disclaims any and all liability, including without limitation special, consequential or incidental damages. ON Semiconductor does not convey any license under its patent rights nor the rights of others.

# MECHANICAL CASE OUTLINE

## PACKAGE DIMENSIONS

ON Semiconductor®

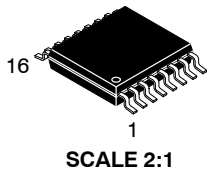

TSSOP-16  
CASE 948F-01  
ISSUE B

DATE 19 OCT 2006

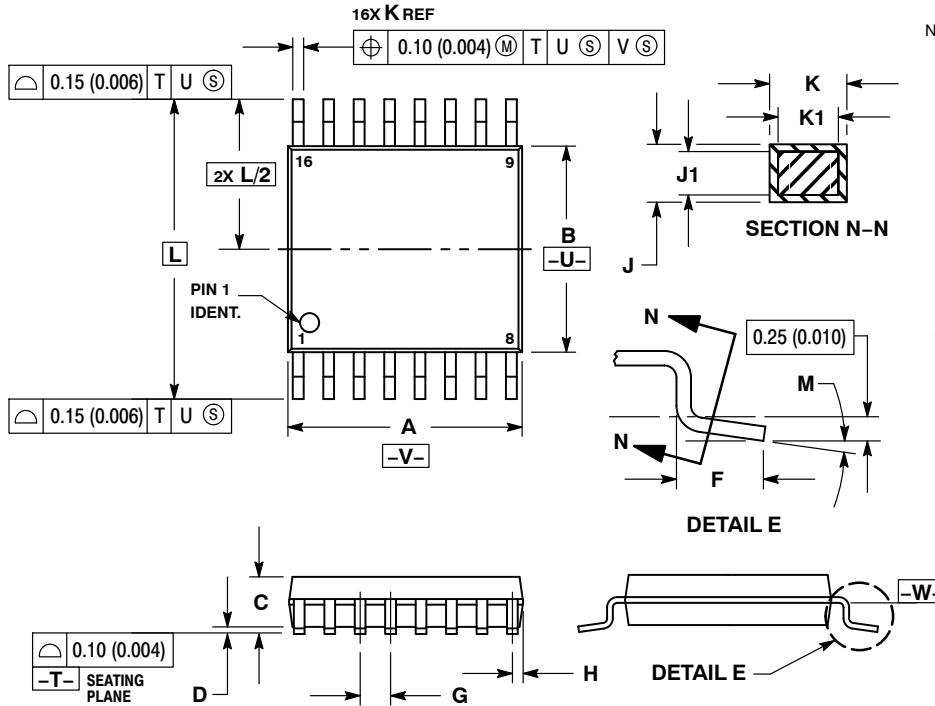

NOTES:

1. DIMENSIONING AND TOLERANCING PER ANSI Y14.5M, 1982.
2. CONTROLLING DIMENSION: MILLIMETER.
3. DIMENSION A DOES NOT INCLUDE MOLD FLASH. PROTRUSIONS OR GATE BURRS. MOLD FLASH OR GATE BURRS SHALL NOT EXCEED 0.15 (0.006) PER SIDE.
4. DIMENSION B DOES NOT INCLUDE INTERLEAD FLASH OR PROTRUSION. INTERLEAD FLASH OR PROTRUSION SHALL NOT EXCEED 0.25 (0.010) PER SIDE.
5. DIMENSION K DOES NOT INCLUDE DAMBAR PROTRUSION. ALLOWABLE DAMBAR PROTRUSION SHALL BE 0.08 (0.003) TOTAL IN EXCESS OF THE K DIMENSION AT MAXIMUM MATERIAL CONDITION.
6. TERMINAL NUMBERS ARE SHOWN FOR REFERENCE ONLY.
7. DIMENSION A AND B ARE TO BE DETERMINED AT DATUM PLANE -W-.

DIM	MILLIMETERS		INCHES	
	MIN	MAX	MIN	MAX
A	4.90	5.10	0.193	0.200
B	4.30	4.50	0.169	0.177
C	---	1.20	---	0.047
D	0.05	0.15	0.002	0.006
F	0.50	0.75	0.020	0.030
G	0.65 BSC		0.026 BSC	
H	0.18	0.28	0.007	0.011
J	0.09	0.20	0.004	0.008
J1	0.09	0.16	0.004	0.006
K	0.19	0.30	0.007	0.012
K1	0.19	0.25	0.007	0.010
L	6.40 BSC		0.252 BSC	
M	0°	8°	0°	8°

SOLDERING FOOTPRINT

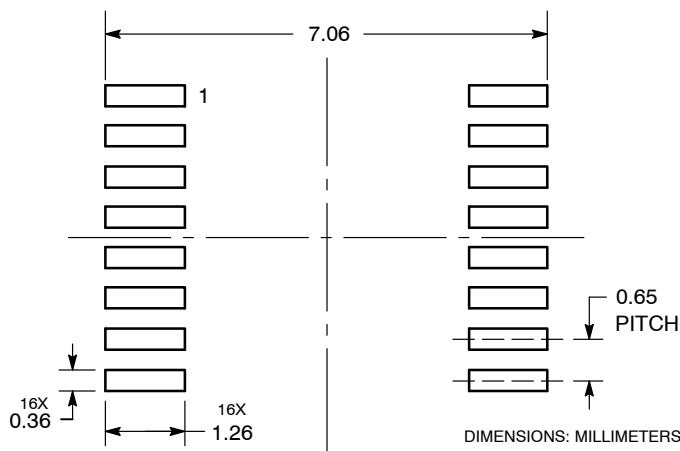

GENERIC MARKING DIAGRAM\*

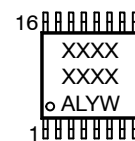

- XXXX = Specific Device Code
- A = Assembly Location
- L = Wafer Lot
- Y = Year
- W = Work Week
- G or ■ = Pb-Free Package

\*This information is generic. Please refer to device data sheet for actual part marking. Pb-Free indicator, "G" or microdot "■", may or may not be present.

DOCUMENT NUMBER:	98ASH70247A	Electronic versions are uncontrolled except when accessed directly from the Document Repository. Printed versions are uncontrolled except when stamped "CONTROLLED COPY" in red.
DESCRIPTION:	TSSOP-16	PAGE 1 OF 1

ON Semiconductor and ON are trademarks of Semiconductor Components Industries, LLC dba ON Semiconductor or its subsidiaries in the United States and/or other countries. ON Semiconductor reserves the right to make changes without further notice to any products herein. ON Semiconductor makes no warranty, representation or guarantee regarding the suitability of its products for any particular purpose, nor does ON Semiconductor assume any liability arising out of the application or use of any product or circuit, and specifically disclaims any and all liability, including without limitation special, consequential or incidental damages. ON Semiconductor does not convey any license under its patent rights nor the rights of others.

**onsemi**, **Onsemi**, and other names, marks, and brands are registered and/or common law trademarks of Semiconductor Components Industries, LLC dba "**onsemi**" or its affiliates and/or subsidiaries in the United States and/or other countries. **onsemi** owns the rights to a number of patents, trademarks, copyrights, trade secrets, and other intellectual property. A listing of **onsemi**'s product/patent coverage may be accessed at [www.onsemi.com/site/pdf/Patent-Marking.pdf](http://www.onsemi.com/site/pdf/Patent-Marking.pdf). **onsemi** reserves the right to make changes at any time to any products or information herein, without notice. The information herein is provided "as-is" and **onsemi** makes no warranty, representation or guarantee regarding the accuracy of the information, product features, availability, functionality, or suitability of its products for any particular purpose, nor does **onsemi** assume any liability arising out of the application or use of any product or circuit, and specifically disclaims any and all liability, including without limitation special, consequential or incidental damages. Buyer is responsible for its products and applications using **onsemi** products, including compliance with all laws, regulations and safety requirements or standards, regardless of any support or applications information provided by **onsemi**. "Typical" parameters which may be provided in **onsemi** data sheets and/or specifications can and do vary in different applications and actual performance may vary over time. All operating parameters, including "Typicals" must be validated for each customer application by customer's technical experts. **onsemi** does not convey any license under any of its intellectual property rights nor the rights of others. **onsemi** products are not designed, intended, or authorized for use as a critical component in life support systems or any FDA Class 3 medical devices or medical devices with a same or similar classification in a foreign jurisdiction or any devices intended for implantation in the human body. Should Buyer purchase or use **onsemi** products for any such unintended or unauthorized application, Buyer shall indemnify and hold **onsemi** and its officers, employees, subsidiaries, affiliates, and distributors harmless against all claims, costs, damages, and expenses, and reasonable attorney fees arising out of, directly or indirectly, any claim of personal injury or death associated with such unintended or unauthorized use, even if such claim alleges that **onsemi** was negligent regarding the design or manufacture of the part. **onsemi** is an Equal Opportunity/Affirmative Action Employer. This literature is subject to all applicable copyright laws and is not for resale in any manner.

---

## ADDITIONAL INFORMATION

### TECHNICAL PUBLICATIONS:

Technical Library: [www.onsemi.com/design/resources/technical-documentation](http://www.onsemi.com/design/resources/technical-documentation)  
onsemi Website: [www.onsemi.com](http://www.onsemi.com)

### ONLINE SUPPORT: [www.onsemi.com/support](http://www.onsemi.com/support)

For additional information, please contact your local Sales Representative at [www.onsemi.com/support/sales](http://www.onsemi.com/support/sales)