

# Customer Information Sheet

DRAWING No.: G125-32496MI-XX-XX-00

IF IN DOUBT - ASK

©

NOT TO SCALE

THIRD ANGLE PROJECTION

ALL DIMENSIONS IN mm

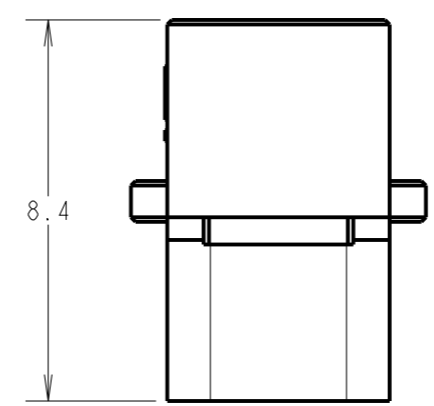
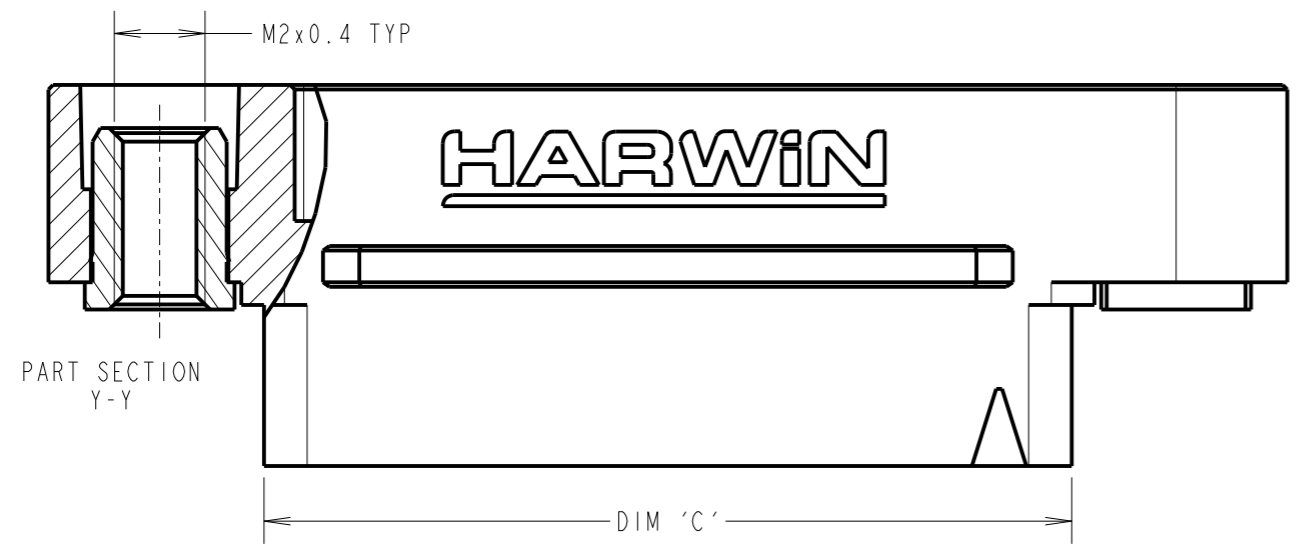
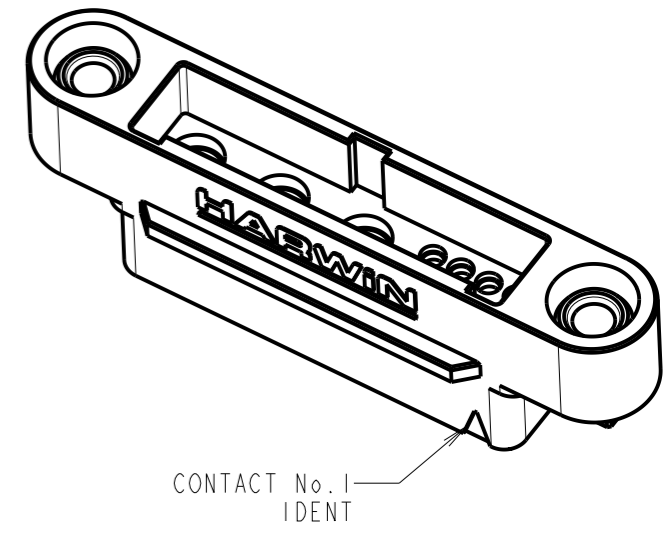
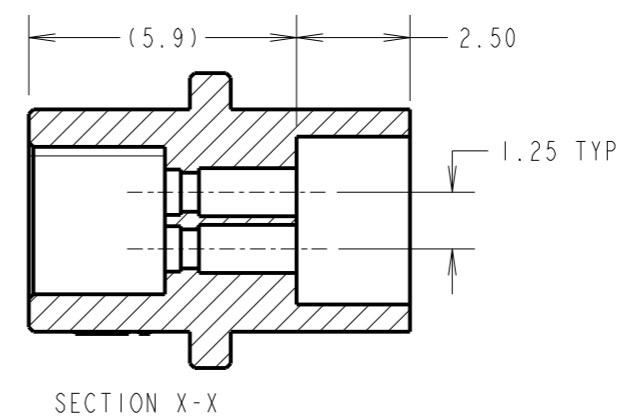
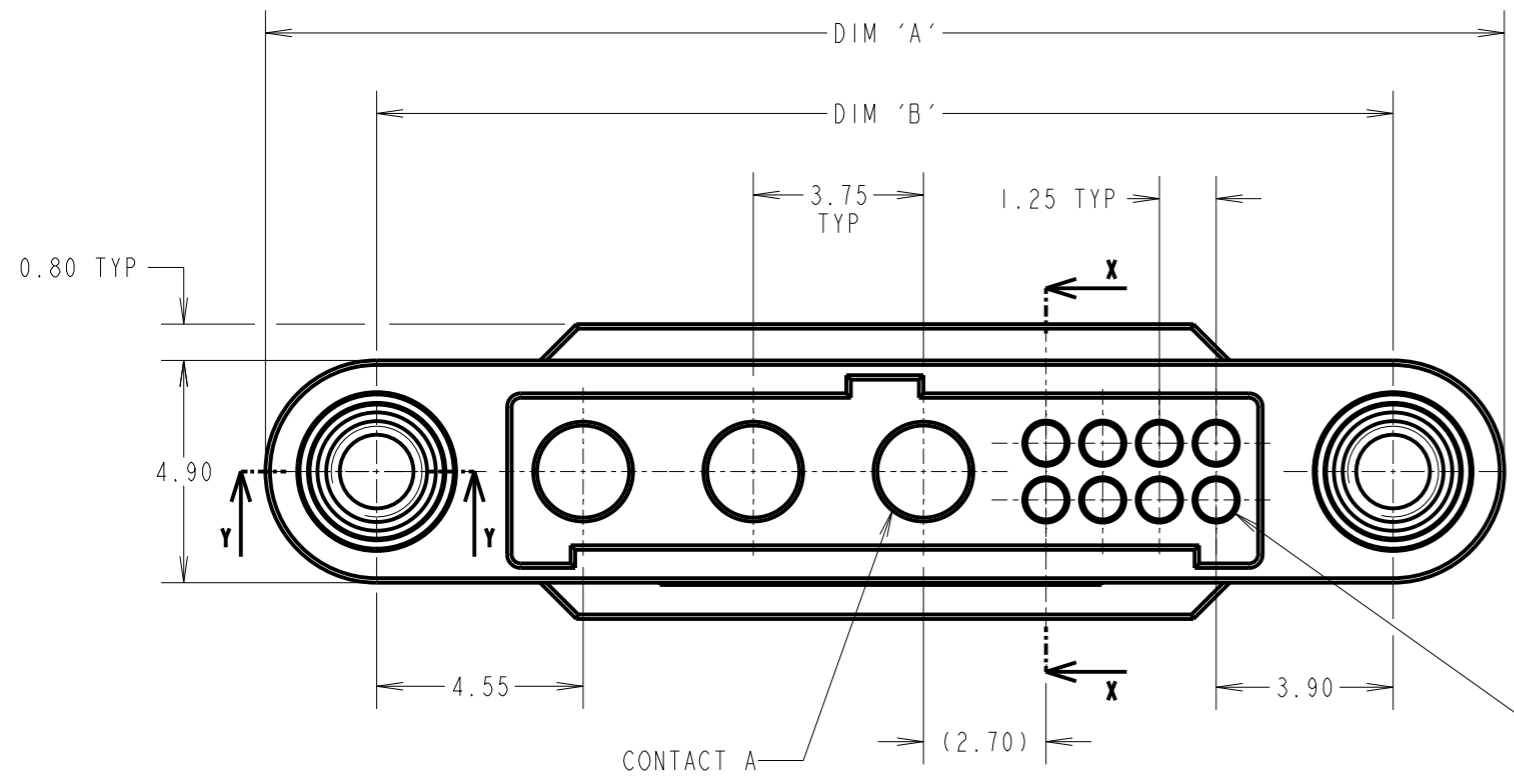

PART No.	No. OF POWER CONTACTS	No. OF SIGNAL CONTACTS
G125-32496MI-02-04-00	02	04
G125-32496MI-03-08-00	03	08
G125-32496MI-04-04-00	04	04
G125-32496MI-02-24-00	02	24
G125-32496MI-04-16-00	04	16
G125-32496MI-06-08-00	06	08

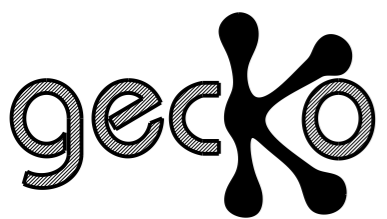

ORDER CODE:  
**G125-32496MI-XX-XX-00**  
 No. OF POWER CONTACTS: SEE TABLE 2      No. OF SIGNAL CONTACTS: SEE TABLE 2

DIMENSION	CALCULATION
DIM 'A'	$((\text{TOTAL No. OF SIGNAL CONTACTS} - 2) \times 0.625) + ((\text{TOTAL No. OF POWER CONTACTS} - 1) \times 3.75) + 16.05$
DIM 'B'	$((\text{TOTAL No. OF SIGNAL CONTACTS} - 2) \times 0.625) + ((\text{TOTAL No. OF POWER CONTACTS} - 1) \times 3.75) + 11.15$
DIM 'C'	$((\text{TOTAL No. OF SIGNAL CONTACTS} - 2) \times 0.625) + ((\text{TOTAL No. OF POWER CONTACTS} - 1) \times 3.75) + 6.60$

RTP	1	27.10.22	31971
NAME	ISS.	DATE	CN/CO
APPROVED: M.RUDKIN			
CHECKED: A.BOXALL			
DRAWN: R.PORTLOCK			
CUSTOMER REF.:			
ASSEMBLY DRG:			

- NOTES:
- HOUSING TO BE USED WITH G125-1010005 OR G125-1020005 MALE SIGNAL CONTACTS, AND G125-1500005 MALE POWER CONTACT.
  - FOR ASSEMBLY INSTRUCTIONS SEE INSTRUCTION SHEET IS-38.
  - FOR MATERIALS, FINISH AND PERFORMANCE SEE COMPONENT SPECIFICATION C125XX (LATEST ISSUE).
  - DRAWING SHOWING G125-32496MI-03-08-00.

**HARWIN**  
 www.harwin.com  
 technical@harwin.com

THIS DRAWING AND ANY INFORMATION OR DESCRIPTIVE MATTER SET OUT HEREON ARE CONFIDENTIAL AND COPYRIGHT PROPERTY OF THE HARWIN GROUP AND MUST NOT BE DISCLOSED, LOANED, COPIED OR USED FOR MANUFACTURING, TENDERING OR FOR ANY OTHER PURPOSE WITHOUT THEIR WRITTEN PERMISSION.

TOLERANCES  
 X. = ±1mm  
 X.X = ±0.50mm  
 X.XX = ±0.20mm  
 X.XXX = ±0.01mm  
 ANGLES = ±5°  
 UNLESS STATED

MATERIAL:  
 SEE NOTE 3  
 FINISH:  
 S/AREA: mm<sup>2</sup>

TITLE:  
 GECKO-MT MALE CABLE HOUSING  
 DRAWING NUMBER:  
**G125-32496MI-XX-XX-00** SHT 2 OF 2