

Low-Voltage, Single and Dual Supply, 8-to-1 Multiplexer

The Intersil ISL84581 device contains precision, bidirectional, analog switches configured as an 8-to-1 multiplexer/demultiplexer. It was designed to operate from a single +2V to +12V single supply or from dual $\pm 2V$ to $\pm 6V$ supplies. The device has an inhibit pin to simultaneously open all signal paths.

The ISL84581 has an ON-resistance of 39Ω with a dual $\pm 5V$ supply and 125Ω with a single +3.3V supply. Each switch can handle rail-to-rail analog signals. The off-leakage current is only 0.02nA at +25°C or 0.2nA at +85°C.

All digital inputs have 0.8V to 2.4V logic thresholds, ensuring TTL/CMOS logic compatibility when using a single 3.3V or +5V supply or dual $\pm 5V$ supplies.

The ISL84581 is a single 8-to-1 multiplexer device. Table 1 summarizes the performance of the part.

TABLE 1. FEATURES AT A GLANCE

CONFIGURATION	SINGLE 8:1 MUX
$\pm 5V$ r_{ON}	39Ω
$\pm 5V$ t_{ON}/t_{OFF}	32ns/18ns
12V r_{ON}	32Ω
12V t_{ON}/t_{OFF}	23ns/15ns
5V r_{ON}	65Ω
5V t_{ON}/t_{OFF}	38ns/19ns
3.3V r_{ON}	125Ω
3.3V t_{ON}/t_{OFF}	70ns/32ns
Package	16 Ld TSSOP, 16 Ld QSOP

Related Literature

- Technical Brief TB363 “Guidelines for Handling and Processing Moisture Sensitive Surface Mount Devices (SMDs)”
- Application Note AN557 “Recommended Test Procedures for Analog Switches”
- Application Note AN520 “CMOS Analog Multiplexers and Switches; Specifications and Application Considerations.”
- Application Note AN1034 “Analog Switch and Multiplexer Applications”

Features

- Fully Specified at 3.3V, 5V, $\pm 5V$, and 12V Supplies for 10% Tolerances
- ON-Resistance (r_{ON}) Max, $V_S = \pm 4.5V$ 50Ω
- ON-Resistance (r_{ON}) Max, $V_S = +3V$ 155Ω
- r_{ON} Matching Between Channels, $V_S = \pm 5V$ $<2\Omega$
- Low Charge Injection, $V_S = \pm 5V$ 1pC (Max)
- Single Supply Operation +2V to +12V
- Dual Supply Operation $\pm 2V$ to $\pm 6V$
- Fast Switching Action ($V_S = +5V$)
 - t_{ON} 38ns
 - t_{OFF} 19ns
- Guaranteed Max Off-leakage 2.5nA
- Guaranteed Break-Before-Make
- TTL, CMOS Compatible
- Pb-free (RoHS Compliant)

Applications

- Battery Powered, Handheld, and Portable Equipment
- Communications Systems
 - Radios
 - Telecom Infrastructure
 - ADSL, VDSL Modems
- Test Equipment
 - Medical Ultrasound
 - Magnetic Resonance Image
 - CT and PET Scanners (MRI)
 - ATE
 - Electrocardiograph
- Audio and Video Signal Routing
- Various Circuits
 - +3V/+5V DACs and ADCs
 - Sample and Hold Circuits
 - Operational Amplifier Gain Switching Networks
 - High Frequency Analog Switching
 - High Speed Multiplexing
 - Integrator Reset Circuits

Pinout

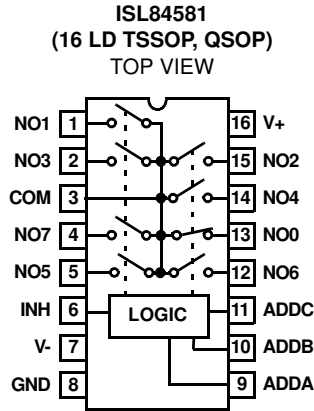

NOTE: Switches Shown for Logic “0” Inputs.

Truth Tables

ISL84581				
INH	ADDC	ADDB	ADDA	SWITCH ON
0	0	0	0	NO0
0	0	0	1	NO1
0	0	1	0	NO2
0	0	1	1	NO3
0	1	0	0	NO4
0	1	0	1	NO5
0	1	1	0	NO6
0	1	1	1	NO7
1	X	X	X	NONE

NOTE: Logic “0” ≤0.8V. Logic “1” ≥2.4V, with V+ between 2.7V and 10V. X = Don’t Care.

Pin Descriptions

PIN	FUNCTION
V+	Positive Power Supply Input
V-	Negative Power Supply Input. Connect to GND for Single Supply Configurations.
GND	Ground Connection
INH	Digital Control Input. Connect to GND for Normal Operation. Connect to V+ to turn all switches off.
ADDx	Address Input Pin
COM	Analog Switch Common Pin
NOx	Analog Switch Normally Open Pin

Ordering Information

PART NUMBER (Note)	PART MARKING	TEMP RANGE (°C)	PACKAGE (Pb-free)	PKG. DWG. #
ISL84581IVZ	84581 IVZ	-40 to +85	16 Ld TSSOP (4.4mm)	M16.173
ISL84581IVZ-T*	84581 IVZ	-40 to +85	16 Ld TSSOP (4.4mm) Tape and Reel	M16.173
ISL84581IAZ	84581 IAZ	-40 to +85	16 Ld QSOP (4.4mm)	M16.15A
ISL84581IAZ-T*	84581 IAZ	-40 to +85	16 Ld QSOP (4.4mm) Tape and Reel	M16.15A

* Please refer to TB347 for details on reel specifications.

NOTE: These Intersil Pb-free plastic packaged products employ special Pb-free material sets, molding compounds/die attach materials, and 100% matte tin plate plus anneal (e3 termination finish, which is RoHS compliant and compatible with both SnPb and Pb-free soldering operations). Intersil Pb-free products are MSL classified at Pb-free peak reflow temperatures that meet or exceed the Pb-free requirements of IPC/JEDEC J STD-020.

Absolute Maximum Ratings

V+ to V-	-0.3V to 15V
V+ to GND	-0.3V to 15V
V- to GND	-15V to 0.3V
Input Voltages	
INH, NOx, ADDx (Note 1)	-0.3 to ((V+) + 0.3V)
Output Voltages	
COM (Note 1)	-0.3 to ((V+) + 0.3V)
Continuous Current (Any Terminal)	±30mA
Peak Current NOx, COM	
(Pulsed 1ms, 10% Duty Cycle, Max)	±100mA
ESD Rating	
Human Body Model (Per Mil-STD-883, Method 3015.7)	>2.5kV

Thermal Information

Thermal Resistance (Typical, Note 2)	θ_{JA} (°C/W)
16 Ld TSSOP Package	110
16 Ld QSOP Package	160
Maximum Junction Temperature (Plastic Package)	+150°C
Maximum Storage Temperature Range	-65°C to +150°C
Pb-free Reflow Profile	see link below
	http://www.intersil.com/pbfree/Pb-FreeReflow.asp

Operating Conditions

Temperature Range	-40°C to +85°C
-------------------	----------------

CAUTION: Do not operate at or near the maximum ratings listed for extended periods of time. Exposure to such conditions may adversely impact product reliability and result in failures not covered by warranty.

NOTES:

1. Signals on NOx, COM, ADDx, INH exceeding V+ or V- are clamped by internal diodes. Limit forward diode current to maximum current ratings.
2. θ_{JA} is measured with the component mounted on a high effective thermal conductivity test board in free air. See Tech Brief TB379 for details.

Electrical Specifications ±5V Supply

Test Conditions: $V_{SUPPLY} = \pm 4.5V$ to $\pm 5.5V$, GND = 0V, $V_{INH} = 2.4V$, $V_{INL} = 0.8V$ (Note 3), Unless Otherwise Specified.

PARAMETER	TEST CONDITIONS	TEMP (°C)	MIN (Notes 4, 8)	TYP	MAX (Notes 4, 8)	UNITS
ANALOG SWITCH CHARACTERISTICS						
Analog Signal Range, V_{ANALOG}	(Note 10)	Full	V-	-	V+	V
ON-Resistance, r_{ON}	$V_S = \pm 4.5V$, $I_{COM} = 2mA$, $V_{NO} = 3V$ (See Figure 5)	25	-	44	60	Ω
		Full	-	-	80	Ω
r_{ON} Matching Between Channels, Δr_{ON}	$V_S = \pm 4.5V$, $I_{COM} = 2mA$, $V_{NO} = 3V$ (Note 5)	25	-	1.3	4	Ω
		Full	-	-	6	Ω
r_{ON} Flatness, $r_{FLAT(ON)}$	$V_S = \pm 4.5V$, $I_{COM} = 2mA$, $V_{NO} = \pm 3V$, 0.1V (Note 6)	25	-	7.5	9	Ω
		Full	-	-	12	Ω
NO OFF Leakage Current, $I_{NO(OFF)}$	$V_S = \pm 5.5V$, $V_{COM} = \pm 4.5V$, $V_{NO} = \bar{+}4.5V$ (Note 7)	25	-	0.02	-	nA
		Full	-	0.2	-	nA
COM OFF Leakage Current, $I_{COM(OFF)}$	$V_S = \pm 5.5V$, $V_{COM} = \pm 4.5V$, $V_{NO} = \bar{+}4.5V$ (Note 7)	25	-	0.02	-	nA
		Full	-	0.2	-	nA
COM ON Leakage Current, $I_{COM(ON)}$	$V_S = \pm 5.5V$, $V_{COM} = V_{NO} = \pm 4.5V$ (Note 7)	25	-	0.02	-	nA
		Full	-	0.2	-	nA
DIGITAL INPUT CHARACTERISTICS						
Input Voltage High, V_{INH} , V_{ADDH}		Full	2.4	-	-	V
Input Voltage Low, V_{INHL} , V_{ADDL}		Full	-	-	0.8	V
Input Current, I_{ADDH} , I_{ADDL} , I_{INH} , I_{INHL}	$V_S = \pm 5.5V$, V_{INH} , $V_{ADD} = 0V$ or V_+ , (Note 9)	Full	-0.5	-	0.5	μA
DYNAMIC CHARACTERISTICS						
INHIBIT Turn-ON Time, t_{ON}	$V_S = \pm 4.5V$, $V_{NO} = \pm 3V$, $R_L = 300\Omega$, $C_L = 35pF$, $V_{IN} = 0$ to 3 (See Figure 1, Note 9)	25	-	35	50	ns
		Full	-	-	60	ns
INHIBIT Turn-OFF Time, t_{OFF}	$V_S = \pm 4.5V$, $V_{NO} = \pm 3V$, $R_L = 300\Omega$, $C_L = 35pF$, $V_{IN} = 0$ to 3 (See Figure 1, Note 9)	25	-	22	35	ns
		Full	-	-	40	ns
Address Transition Time, t_{TRANS}	$V_S = \pm 4.5V$, $V_{NO} = \pm 3V$, $R_L = 300\Omega$, $C_L = 35pF$, $V_{IN} = 0$ to 3 (See Figure 1, Note 9)	25	-	43	60	ns
		Full	-	-	70	ns

ISL84581

Electrical Specifications ±5V Supply

Test Conditions: $V_{SUPPLY} = \pm 4.5V$ to $\pm 5.5V$, $GND = 0V$, $V_{INH} = 2.4V$, $V_{INL} = 0.8V$ (Note 3), Unless Otherwise Specified. (Continued)

PARAMETER	TEST CONDITIONS	TEMP (°C)	MIN (Notes 4, 8)	TYP	MAX (Notes 4, 8)	UNITS
Break-Before-Make Time, t_{BBM}	$V_S = \pm 5.5V$, $V_{NO} = 3V$, $R_L = 300\Omega$, $C_L = 35pF$, $V_{IN} = 0$ to $3V$ (See Figure 3, Note 9)	Full	2	7	-	ns
Charge Injection, Q	$C_L = 1.0nF$, $V_G = 0V$, $R_G = 0\Omega$ (See Figure 2, Note 9)	25	-	0.3	1	pC
NO OFF Capacitance, C_{OFF}	$f = 1MHz$, $V_{NO} = V_{COM} = 0V$ (See Figure 6)	25	-	3	-	pF
COM OFF Capacitance, C_{OFF}	$f = 1MHz$, $V_{NO} = V_{COM} = 0V$ (See Figure 6)	25	-	21	-	pF
COM ON Capacitance, $C_{COM(ON)}$	$f = 1MHz$, $V_{NO} = V_{COM} = 0V$ (See Figure 6)	25	-	26	-	pF
OFF-Isolation	$R_L = 50\Omega$, $C_L = 15pF$, $f = 100kHz$, $V_{NOx} = 1V_{RMS}$ (See Figures 4 and 18)	25	-	92	-	dB
POWER SUPPLY CHARACTERISTICS						
Power Supply Range	(Note 10)	Full	± 2	-	± 6	V
Positive Supply Current, I_+	$V_S = \pm 5.5V$, V_{INH} , $V_{ADD} = 0V$ or V_+ , Switch On or Off, (Note 9)	Full	-7	-	7	μA
Negative Supply Current, I_-		Full	-1	-	1	μA

Electrical Specifications +12V Supply

Test Conditions: $V_+ = +10.8V$ to $+13.2V$, $GND = 0V$, $V_{INH} = 4V$, $V_{INL} = 0.8V$ (Note 3), Unless Otherwise Specified.

PARAMETER	TEST CONDITIONS	TEMP (°C)	MIN (Notes 4, 8)	TYP	MAX (Notes 4, 8)	UNITS
ANALOG SWITCH CHARACTERISTICS						
Analog Signal Range, V_{ANALOG}	(Note 10)	Full	0	-	V_+	V
ON-Resistance, r_{ON}	$V_+ = 10.8V$, $I_{COM} = 1.0mA$, $V_{NO} = 9V$ (See Figure 5)	25	-	37	45	Ω
		Full	-	-	55	Ω
r_{ON} Matching Between Channels, Δr_{ON}	$V_+ = 10.8V$, $I_{COM} = 1.0mA$, $V_{NO} = 9V$ (Note 5)	25	-	1.2	2	Ω
		Full	-	-	2	Ω
r_{ON} Flatness, $r_{FLAT(ON)}$	$V_+ = 10.8V$, $I_{COM} = 1.0mA$, $V_{NO} = 3V, 6V, 9V$ (Note 6)	Full	-	5	-	Ω
NO OFF Leakage Current, $I_{NO(OFF)}$	$V_+ = 13.2V$, $V_{COM} = 1V, 12V$, $V_{NO} = 12V, 1V$ (Note 7)	25	-	0.02	-	nA
		Full	-	0.2	-	nA
COM OFF Leakage Current, $I_{COM(OFF)}$	$V_+ = 13.2V$, $V_{COM} = 12V, 1V$, $V_{NO} = 1V, 12V$ (Note 7)	25	-	0.02	-	nA
		Full	-	0.2	-	nA
COM ON Leakage Current, $I_{COM(ON)}$	$V_+ = 13.2V$, $V_{COM} = 1V, 12V$, $V_{NO} = 1V, 12V$, or floating (Note 7)	25	-	0.02	-	nA
		Full	-	0.2	-	nA
DIGITAL INPUT CHARACTERISTICS						
Input Voltage High, V_{INHh} , V_{ADDH}		Full	3.7	3.3	-	V
Input Voltage Low, V_{INHL} , V_{ADDL}		Full	-	2.7	0.8	V
Input Current, I_{ADDH} , I_{ADDL} , I_{INHh} , I_{INHL}	$V_+ = 13.2V$, V_{INH} , $V_{ADD} = 0V$ or V_+	Full	-0.5	-	0.5	μA
DYNAMIC CHARACTERISTICS						
INHIBIT Turn-ON Time, t_{ON}	$V_+ = 10.8V$, $V_{NO} = 10V$, $R_L = 300\Omega$, $C_L = 35pF$, $V_{IN} = 0$ to 4 (See Figure 1, Note 9)	25	-	24	40	ns
		Full	-	-	45	ns
INHIBIT Turn-OFF Time, t_{OFF}	$V_+ = 10.8V$, $V_{NO} = 10V$, $R_L = 300\Omega$, $C_L = 35pF$, $V_{IN} = 0$ to 4 (See Figure 1, Note 9)	25	-	15	30	ns
		Full	-	-	35	ns

ISL84581

Electrical Specifications +12V Supply

Test Conditions: $V_+ = +10.8V$ to $+13.2V$, $GND = 0V$, $V_{INH} = 4V$, $V_{INL} = 0.8V$ (Note 3), Unless Otherwise Specified. (Continued)

PARAMETER	TEST CONDITIONS	TEMP (°C)	MIN (Notes 4, 8)	TYP	MAX (Notes 4, 8)	UNITS
Address Transition Time, t_{TRANS}	$V_+ = 10.8V$, $V_{NO} = 10V$, $R_L = 300\Omega$, $C_L = 35pF$, $V_{IN} = 0$ to 4 (See Figure 1, Note 9)	25	-	27	50	ns
		Full	-	-	55	ns
Break-Before-Make Time Delay, t_D	$V_+ = 13.2V$, $R_L = 300\Omega$, $C_L = 35pF$, $V_{NO} = 10V$, $V_{IN} = 0$ to 4 (See Figure 3, Note 9)	Full	2	5	-	ns
Charge Injection, Q	$C_L = 1.0nF$, $V_G = 0V$, $R_G = 0\Omega$ (See Figure 2, Note 9)	25	-	2.7	5	pC
OFF-Isolation	$R_L = 50\Omega$, $C_L = 15pF$, $f = 100kHz$ (See Figures 4 and 18)	25	-	92	-	dB
NO OFF Capacitance, C_{OFF}	$f = 1MHz$, $V_{NO} = V_{COM} = 0V$ (See Figure 6)	25	-	3	-	pF
COM OFF Capacitance, $C_{COM(OFF)}$	$f = 1MHz$, $V_{NO} = V_{COM} = 0V$ (See Figure 6)	25	-	21	-	pF
COM ON Capacitance, $C_{COM(ON)}$	$f = 1MHz$, $V_{NO} = V_{COM} = 0V$ (See Figure 6)	25	-	26	-	pF
POWER SUPPLY CHARACTERISTICS						
Power Supply Range	(Note 10)	Full	2	-	12	V
Positive Supply Current, I_+	$V_+ = 13.2V$, V_{INH} , $V_{ADD} = 0V$ or V_+ , all channels on or off	Full	-7	-	7	μA

Electrical Specifications 5V Supply

Test Conditions: $V_+ = +4.5V$ to $+5.5V$, $V_- = GND = 0V$, $V_{INH} = 2.4V$, $V_{INL} = 0.8V$ (Note 3), Unless Otherwise Specified.

PARAMETER	TEST CONDITIONS	TEMP (°C)	MIN (Notes 4, 8)	TYP	MAX (Notes 4, 8)	UNITS
ANALOG SWITCH CHARACTERISTICS						
Analog Signal Range, V_{ANALOG}	(Note 10)	Full	0	-	V_+	V
ON-Resistance, r_{ON}	$V_+ = 4.5V$, $I_{COM} = 1.0mA$, $V_{NO} = 3.5V$ (See Figure 5)	25	-	81	100	Ω
		Full	-	-	120	Ω
r_{ON} Matching Between Channels, Δr_{ON}	$V_+ = 4.5V$, $I_{COM} = 1.0mA$, $V_{NO} = 3V$ (Note 5)	25	-	2.2	4	Ω
		Full	-	-	6	Ω
r_{ON} Flatness, $r_{FLAT(ON)}$	$V_+ = 4.5V$, $I_{COM} = 1.0mA$, $V_{NO} = 1V, 2V, 3V$ (Note 6)	Full	-	11.5	-	Ω
NO OFF Leakage Current, $I_{NO(OFF)}$	$V_+ = 5.5V$, $V_{COM} = 1V, 4.5V$, $V_{NO} = 4.5V, 1V$ (Note 7)	25	-	0.02	-	nA
		Full	-	0.2	-	nA
COM OFF Leakage Current, $I_{COM(OFF)}$	$V_+ = 5.5V$, $V_{COM} = 1V, 4.5V$, $V_{NO} = 4.5V, 1V$ (Note 7)	25	-	0.02	-	nA
		Full	-	0.2	-	nA
COM ON Leakage Current, $I_{COM(ON)}$	$V_+ = 5.5V$, $V_{COM} = V_{NO} = 4.5V$ (Note 7)	25	-	0.02	-	nA
		Full	-	0.2	-	nA
DIGITAL INPUT CHARACTERISTICS						
Input Voltage High, V_{INH} , V_{ADDH}		Full	2.4	-	-	V
Input Voltage Low, V_{INL} , V_{ADDL}		Full	-	-	0.8	V
Input Current, I_{ADDH} , I_{ADDL} , I_{INH} , I_{INL}	$V_+ = 5.5V$, V_{INH} , $V_{ADD} = 0V$ or V_+ , (Note 9)	Full	-0.5	-	0.5	μA
DYNAMIC CHARACTERISTICS						
INHIBIT Turn-ON Time, t_{ON}	$V_+ = 4.5V$, $V_{NO} = 3V$, $R_L = 300\Omega$, $C_L = 35pF$, $V_{IN} = 0$ to 3V (see Figure 1, Note 9)	25	-	43	60	ns
		Full	-	-	70	ns

ISL84581

Electrical Specifications 5V Supply

Test Conditions: $V_+ = +4.5V$ to $+5.5V$, $V_- = GND = 0V$, $V_{INH} = 2.4V$, $V_{INL} = 0.8V$ (Note 3), Unless Otherwise Specified. (Continued)

PARAMETER	TEST CONDITIONS	TEMP (°C)	MIN (Notes 4, 8)	TYP	MAX (Notes 4, 8)	UNITS
INHIBIT Turn-OFF Time, t_{OFF}	$V_+ = 4.5V$, $V_{NO} = 3V$, $R_L = 300\Omega$, $C_L = 35pF$, $V_{IN} = 0$ to $3V$ (see Figure 1, Note 9)	25	-	20	35	ns
		Full	-	-	40	ns
Address Transition Time, t_{TRANS}	$V_+ = 4.5V$, $V_{NO} = 3V$, $R_L = 300\Omega$, $C_L = 35pF$, $V_{IN} = 0$ to $3V$ (see Figure 1, Note 9)	25	-	51	70	ns
		Full	-	-	85	ns
Break-Before-Make Time, t_{BBM}	$V_+ = 5.5V$, $V_{NO} = 3V$, $R_L = 300\Omega$, $C_L = 35pF$, $V_{IN} = 0$ to $3V$ (see Figure 3, Note 9)	Full	2	9	-	ns
Charge Injection, Q	$C_L = 1.0nF$, $V_G = 0V$, $R_G = 0\Omega$ (see Figure 2, Note 9)	25	-	0.6	1.5	pC
OFF-Isolation	$R_L = 50\Omega$, $C_L = 15pF$, $f = 100kHz$, $V_{NOx} = 1V_{RMS}$ (see Figures 4 and 18)	25	-	92	-	dB
POWER SUPPLY CHARACTERISTICS						
Power Supply Range	(Note 10)	Full	2	-	12	V
Positive Supply Current, I_+	$V_+ = 5.5V$, $V_- = 0V$, V_{INH} , $V_{ADD} = 0V$ or V_+ , Switch On or Off, (Note 9)	Full	-7	-	7	μA
Positive Supply Current, I_-		Full	-1	-	1	μA

Electrical Specifications 3.3V Supply

Test Conditions: $V_+ = +3.0V$ to $+3.6V$, $V_- = GND = 0V$, $V_{INH} = 2.4V$, $V_{INL} = 0.8V$ (Note 3), Unless Otherwise Specified

PARAMETER	TEST CONDITIONS	TEMP (°C)	MIN (Notes 4, 8)	TYP	MAX (Notes 4, 8)	UNITS
ANALOG SWITCH CHARACTERISTICS						
Analog Signal Range, V_{ANALOG}		Full	0	-	V_+	V
ON-Resistance, r_{ON}	$V_+ = 3.0V$, $I_{COM} = 1.0mA$, $V_{NO} = 1.5V$ (see Figure 5)	25	-	135	180	Ω
		Full	-	-	200	Ω
r_{ON} Matching Between Channels, Δr_{ON}	$V_+ = 3.0V$, $I_{COM} = 1.0mA$, $V_{NO} = 1.5V$ (Note 5)	25	-	3.4	8	Ω
		Full	-	-	10	Ω
r_{ON} Flatness, $r_{FLAT(ON)}$	$V_+ = 3.0V$, $I_{COM} = 1.0mA$, $V_{NO} = 0.5V, 1V, 2V$ (Note 6)	Full	-	34	-	Ω
NO OFF Leakage Current, $I_{NO(OFF)}$	$V_+ = 3.6V$, $V_{COM} = 0V, 4.5V$, $V_{NO} = 3V, 1V$ (Note 7)	25	-	0.02	-	nA
		Full	-	0.2	-	nA
COM OFF Leakage Current, $I_{COM(OFF)}$	$V_+ = 3.6V$, $V_{COM} = 0V, 4.5V$, $V_{NO} = 3V, 1V$ (Note 7)	25	-	0.02	-	nA
		Full	-	0.2	-	nA
COM ON Leakage Current, $I_{COM(ON)}$	$V_+ = 3.6V$, $V_{COM} = V_{NO} = 3V$ (Note 7)	25	-	0.02	-	nA
		Full	-	0.2	-	nA
DIGITAL INPUT CHARACTERISTICS						
Input Voltage High, V_{INH} , V_{ADDH}		Full	2.4	-	-	V
Input Voltage Low, V_{INHL} , V_{ADDL}		Full	-	-	0.8	V
Input Current, I_{ADDH} , I_{ADDL} , I_{INH} , I_{INHL}	$V_+ = 3.6V$, V_{INH} , $V_{ADD} = 0V$ or V_+ , (Note 9)	Full	-0.5	-	0.5	μA
DYNAMIC CHARACTERISTICS						
INHIBIT Turn-ON Time, t_{ON}	$V_+ = 3.0V$, $V_{NO} = 1.5V$, $R_L = 300\Omega$, $C_L = 35pF$, $V_{IN} = 0V$ to $3V$ (see Figure 1, Note 9)	25	-	82	100	ns
		Full	-	-	120	ns

Electrical Specifications 3.3V Supply Test Conditions: $V_+ = +3.0V$ to $+3.6V$, $V_- = GND = 0V$, $V_{INH} = 2.4V$, $V_{INL} = 0.8V$ (Note 3), Unless Otherwise Specified **(Continued)**

PARAMETER	TEST CONDITIONS	TEMP (°C)	MIN (Notes 4, 8)	TYP	MAX (Notes 4, 8)	UNITS
INHIBIT Turn-OFF Time, t_{OFF}	$V_+ = 3.0V$, $V_{NO} = 1.5V$, $R_L = 300\Omega$, $C_L = 35pF$, $V_{IN} = 0V$ to $3V$ (see Figure 1, Note 9)	25	-	37	50	ns
		Full	-	-	60	ns
Address Transition Time, t_{TRANS}	$V_+ = 3.0V$, $V_{NO} = 1.5V$, $R_L = 300\Omega$, $C_L = 35pF$, $V_{IN} = 0V$ to $3V$ (see Figure 1, Note 9)	25	-	96	120	ns
		Full	-	-	145	ns
Break-Before-Make Time, t_{BBM}	$V_+ = 3.6V$, $V_{NO} = 1.5V$, $R_L = 300\Omega$, $C_L = 35pF$, $V_{IN} = 0V$ to $3V$ (see Figure 3, Note 9)	Full	3	13	-	ns
Charge Injection, Q	$C_L = 1.0nF$, $V_G = 0V$, $R_G = 0\Omega$ (see Figure 2, Note 9)	25	-	0.3	1	pC
OFF-Isolation	$R_L = 50\Omega$, $C_L = 15pF$, $f = 100kHz$, $V_{NO} = 1V_{RMS}$ (see Figures 4 and 18)	25	-	92	-	dB
POWER SUPPLY CHARACTERISTICS						
Power Supply Range	(Note 10)	Full	2	-	12	V

NOTES:

- V_{IN} = Input logic voltage to configure the device in a given state.
- The algebraic convention, whereby the most negative value is a minimum and the most positive a maximum, is used in this data sheet.
- $\Delta r_{ON} = r_{ON} (MAX) - r_{ON} (MIN)$.
- Flatness is defined as the difference between maximum and minimum value of on-resistance over the specified analog signal range.
- Leakage parameter is 100% tested at high temp, and guaranteed by correlation at $+25^\circ C$.
- Parameters with MIN and/or MAX limits are 100% tested at $+25^\circ C$, unless otherwise specified. Temperature limits established by characterization and are not production tested.
- Limits established by characterization and are not production tested.
- Limits should be considered typical and are not production tested.

Test Circuits and Waveforms

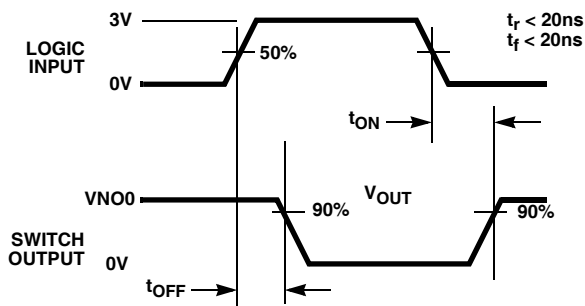

Logic input waveform is inverted for switches that have the opposite logic sense.

FIGURE 1A. INHIBIT t_{ON}/t_{OFF} MEASUREMENT POINTS

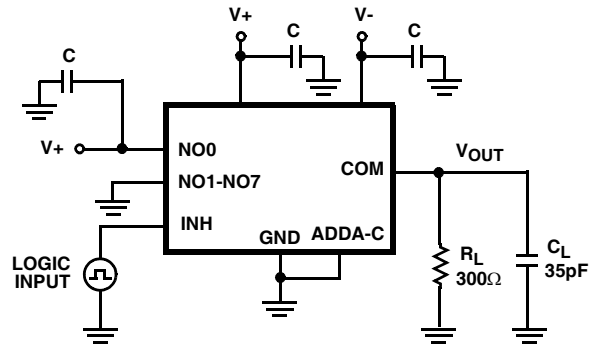

Repeat test for other switches. C_L includes fixture and stray capacitance.

$$V_{OUT} = V_{(NO \text{ or } NC)} \frac{R_L}{R_L + r_{ON}}$$

FIGURE 1B. INHIBIT t_{ON}/t_{OFF} TEST CIRCUIT

Test Circuits and Waveforms (Continued)

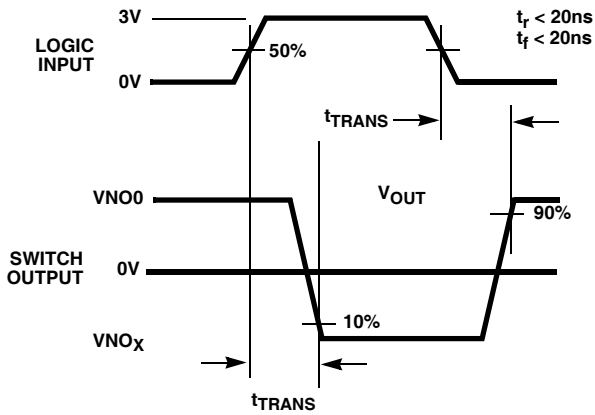

Logic input waveform is inverted for switches that have the opposite logic sense.

FIGURE 1C. ADDRESS t_{TRANS} MEASUREMENT POINTS

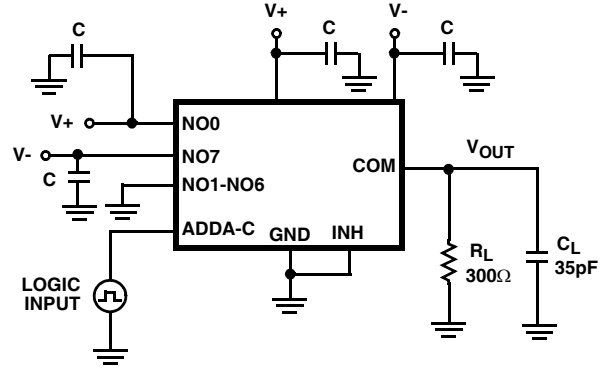

Repeat test for other switches. C_L includes fixture and stray capacitance.

$$V_{OUT} = V_{(NO \text{ or } NC)} \frac{R_L}{R_L + r_{ON}}$$

FIGURE 1D. ADDRESS t_{TRANS} TEST CIRCUIT

FIGURE 1. SWITCHING TIMES

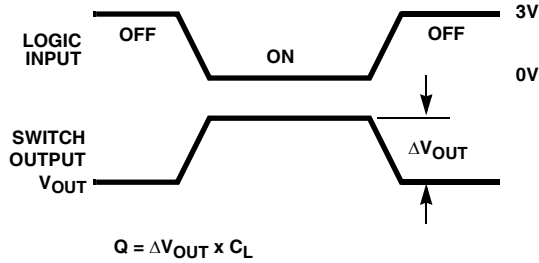
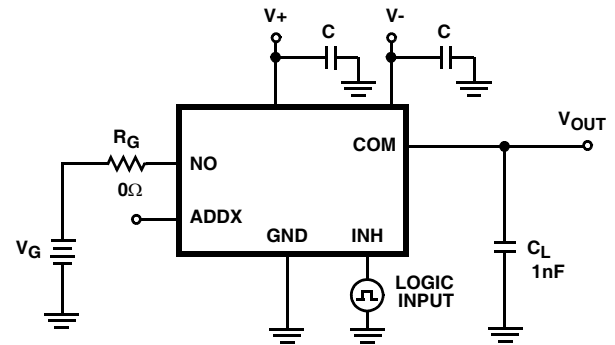

FIGURE 2A. Q MEASUREMENT POINTS



Repeat test for other switches.

FIGURE 2B. Q TEST CIRCUIT

FIGURE 2. CHARGE INJECTION

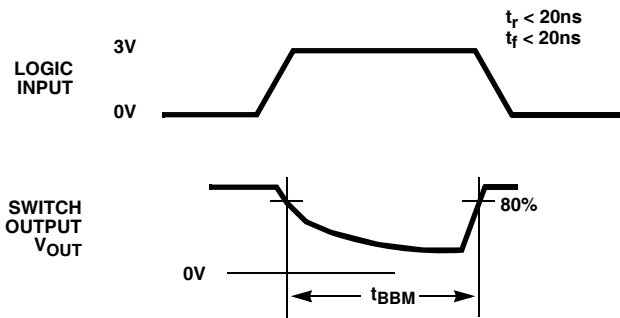
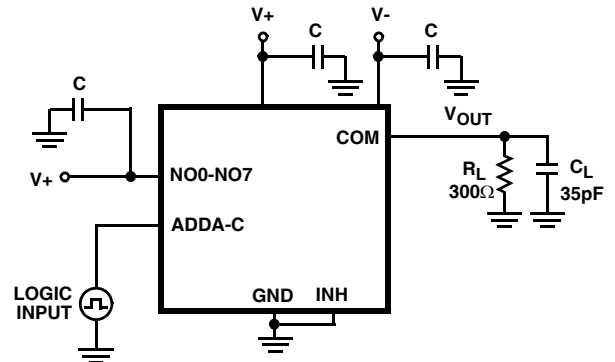

FIGURE 3A. t_{BBM} MEASUREMENT POINTS



Repeat test for other switches. C_L includes fixture and stray capacitance.

FIGURE 3B. t_{BBM} TEST CIRCUIT

FIGURE 3. BREAK-BEFORE-MAKE TIME

Test Circuits and Waveforms (Continued)

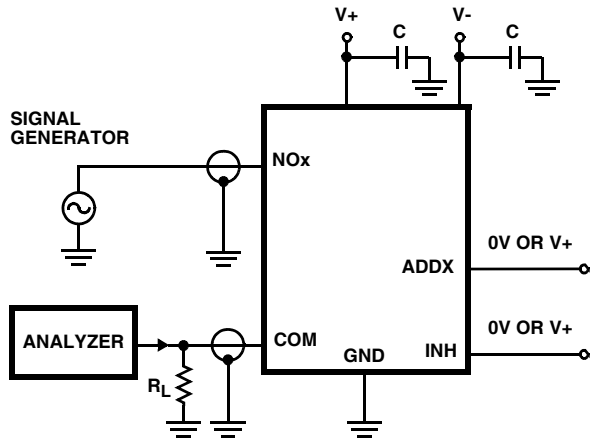

FIGURE 4. OFF-ISOLATION TEST CIRCUIT

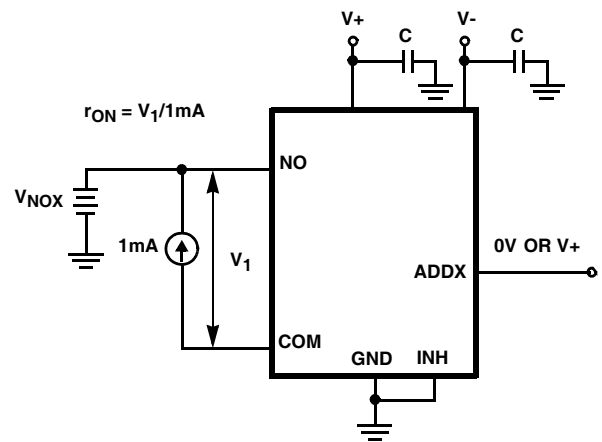

FIGURE 5. r_{ON} TEST CIRCUIT

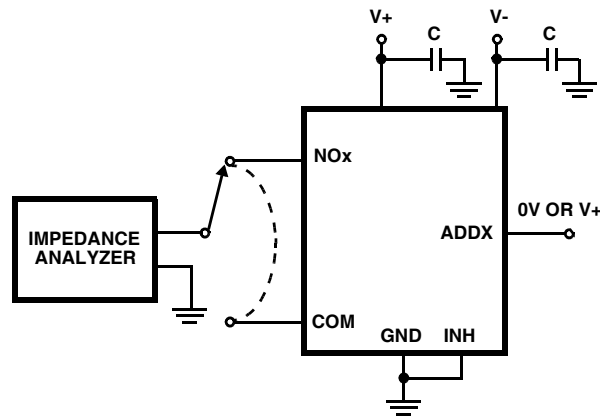

FIGURE 6. CAPACITANCE TEST CIRCUIT

Detailed Description

The ISL84581 multiplexer offers precise switching capability from bipolar $\pm 2\text{V}$ to $\pm 6\text{V}$ supplies or a single 2V to 12V supply. When powered with dual $\pm 5\text{V}$ supplies the part has low ON-resistance (39Ω) and high speed operation ($t_{\text{ON}} = 38\text{ns}$, $t_{\text{OFF}} = 19\text{ns}$).

It has an inhibit pin to simultaneously open all signal paths.

The device is especially well suited for applications using $\pm 5\text{V}$ supplies. With $\pm 5\text{V}$ supplies the performance (r_{ON} , Leakage, Charge Injection, etc.) is best in class.

High frequency applications also benefit from the wide bandwidth and high off-isolation.

Supply Sequencing And Overvoltage Protection

With any CMOS device, proper power supply sequencing is required to protect the device from excessive input currents which might permanently damage the IC. All I/O pins contain ESD protection diodes from the pin to V_+ and to V_- (see Figure 7). To prevent forward biasing these diodes, V_+ and V_- must be applied before any input signals, and input signal voltages must remain between V_+ and V_- . If these conditions cannot be guaranteed, then one of the following two protection methods should be employed.

Logic inputs can easily be protected by adding a $1\text{k}\Omega$ resistor in series with the input (see Figure 7). The resistor limits the input current below the threshold that produces permanent damage, and the sub-microamp input current produces an insignificant voltage drop during normal operation.

This method is not applicable for the signal path inputs. Adding a series resistor to the switch input defeats the purpose of using a low r_{ON} switch, so two small signal diodes can be added in series with the supply pins to provide overvoltage protection for all pins (see Figure 7). These additional diodes limit the analog signal from 1V below V_+ to 1V above V_- . The low leakage current performance is unaffected by this approach, but the switch resistance may increase, especially at low supply voltages.

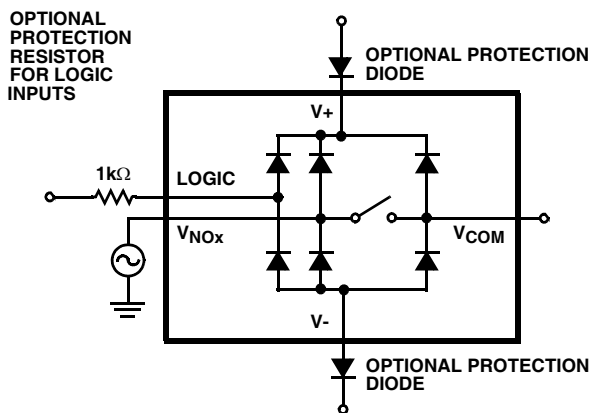

FIGURE 7. INPUT OVERVOLTAGE PROTECTION

Power-Supply Considerations

The ISL84581 construction is typical of most CMOS analog switches, in that it has three supply pins: V_+ , V_- , and GND. V_+ and V_- drive the internal CMOS switches and set their analog voltage limits, so there are no connections between the analog signal path and GND. Unlike switches with a 13V maximum supply voltage, the ISL84581 15V maximum supply voltage provides plenty of room for the 10% tolerance of 12V supplies ($\pm 6\text{V}$ or 12V single supply), as well as room for overshoot and noise spikes.

The part performs equally well when operated with bipolar or single voltage supplies. The minimum recommended supply voltage is 2V single supply or $\pm 2\text{V}$ dual supply. It is important to note that the input signal range, switching times, and ON-resistance degrade at lower supply voltages. Refer to the “Electrical Specification” tables on page 4 and “Typical Performance Curves” on page 11 for details.

V_+ and GND power the internal logic setting the digital switching point of the level shifters. The level shifters convert the logic levels to switched V_+ and V_- signals to drive the analog switch gate terminals.

Logic-Level Thresholds

V_+ and GND power the internal logic stages, so V_- has no effect on logic thresholds. This ISL84581 is TTL compatible (0.8V and 2.4V) over a V_+ supply range of 2.7V to 10V . At 12V the V_{IH} level is about 3.3V . This is still below the CMOS guaranteed high output minimum level of 4V , but noise margin is reduced. For best results with a 12V supply, use a logic family that provides a V_{OH} greater than 4V .

The digital input stages draw supply current whenever the digital input voltage is not at one of the supply rails. Driving the digital input signals from GND to V_+ with a fast transition time minimizes power dissipation.

High-Frequency Performance

In 50Ω systems, signal response is reasonably flat even past 100MHz (see Figures 16 and 17). Figures 16 and 17 also illustrate that the frequency response is very consistent over varying analog signal levels.

An OFF switch acts like a capacitor and passes higher frequencies with less attenuation, resulting in signal feed through from a switch’s input to its output. Off-isolation is the resistance to this feed through. Figure 18 details the high off isolation of the ISL84581. At 10MHz , off-isolation is about 55dB in 50Ω systems, decreasing approximately 20dB per decade as frequency increases. Higher load impedances decrease off-isolation due to the voltage divider action of the switch OFF impedance and the load impedance.

Leakage Considerations

Reverse ESD protection diodes are internally connected between each analog-signal pin and both V+ and V-. One of these diodes conducts if any analog signal exceeds V+ or V-.

Virtually all the analog leakage current comes from the ESD diodes to V+ or V-. Although the ESD diodes on a given signal pin are identical and therefore fairly well balanced, they are reverse biased differently. Each is biased by either

V+ or V- and the analog signal. This means their leakages will vary as the signal varies. The difference in the two diode leakages to the V+ and V- pins constitutes the analog-signal-path leakage current. All analog leakage current flows between each pin and one of the supply terminals, not to the other switch terminal. This is why both sides of a given switch can show leakage currents of the same or opposite polarity. There is no connection between the analog signal paths and GND.

Typical Performance Curves $T_A = +25^\circ\text{C}$, Unless Otherwise Specified

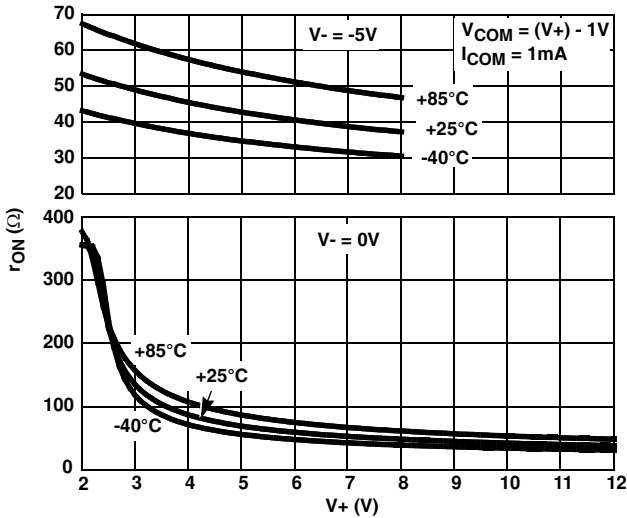

FIGURE 8. ON-RESISTANCE vs SUPPLY VOLTAGE

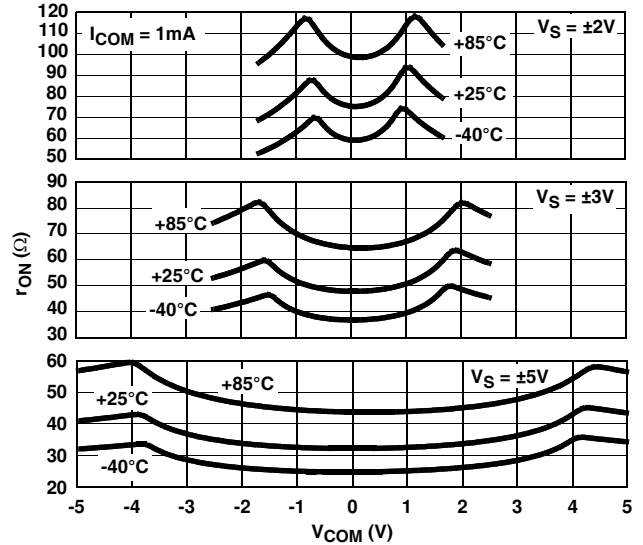

FIGURE 9. ON-RESISTANCE vs SWITCH VOLTAGE

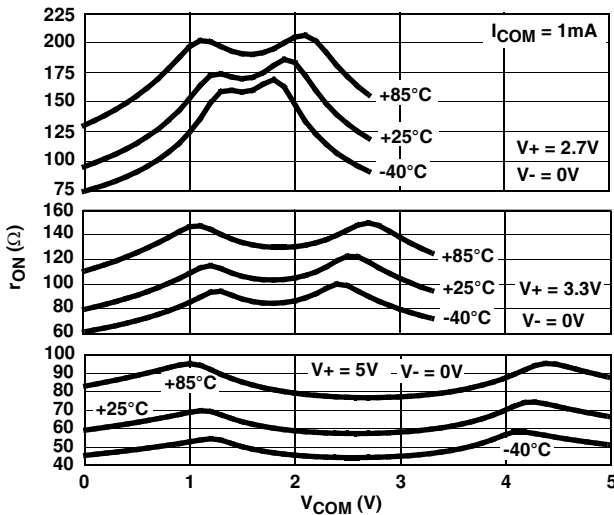

FIGURE 10. ON-RESISTANCE vs SWITCH VOLTAGE

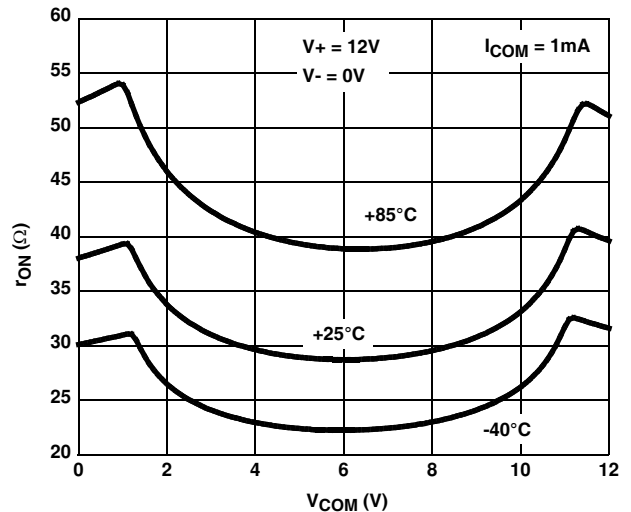

FIGURE 11. ON-RESISTANCE vs SWITCH VOLTAGE

Typical Performance Curves $T_A = +25^\circ\text{C}$, Unless Otherwise Specified (Continued)

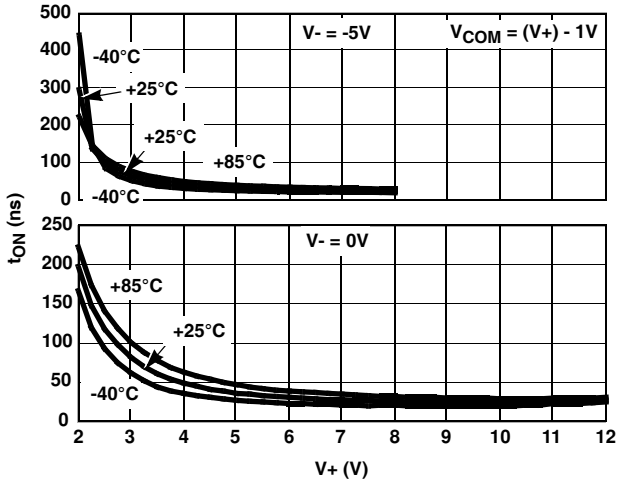

FIGURE 12. INHIBIT TURN-ON TIME vs SUPPLY VOLTAGE

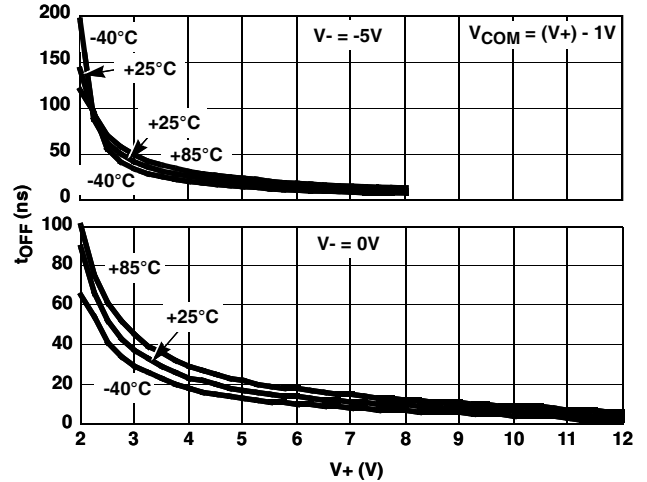

FIGURE 13. INHIBIT TURN-OFF TIME vs SUPPLY VOLTAGE

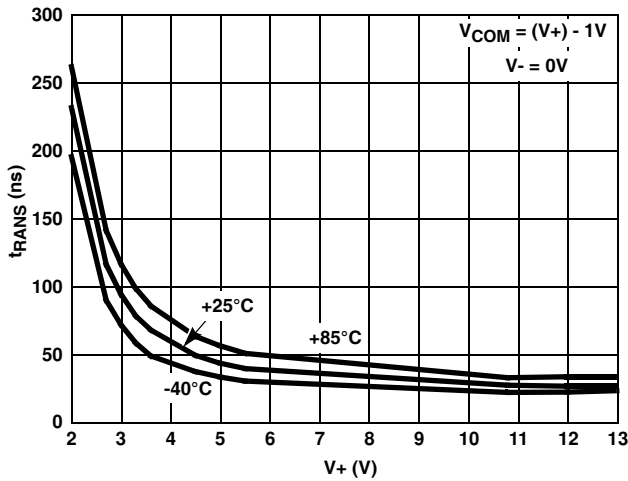

FIGURE 14. ADDRESS TRANS TIME vs SINGLE SUPPLY VOLTAGE

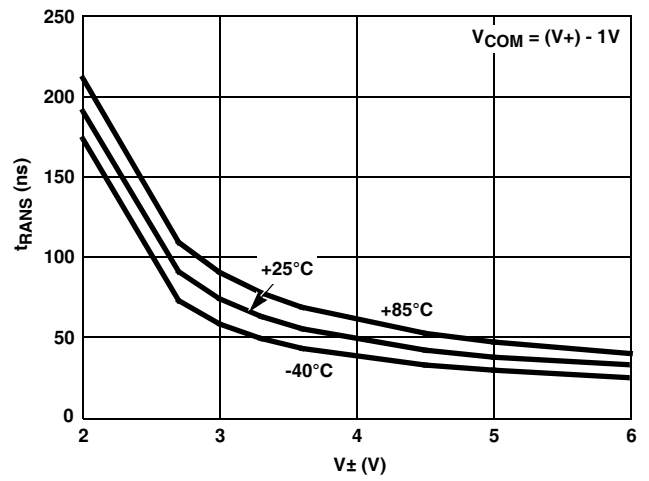

FIGURE 15. ADDRESS TRANS TIME vs DUAL SUPPLY VOLTAGE

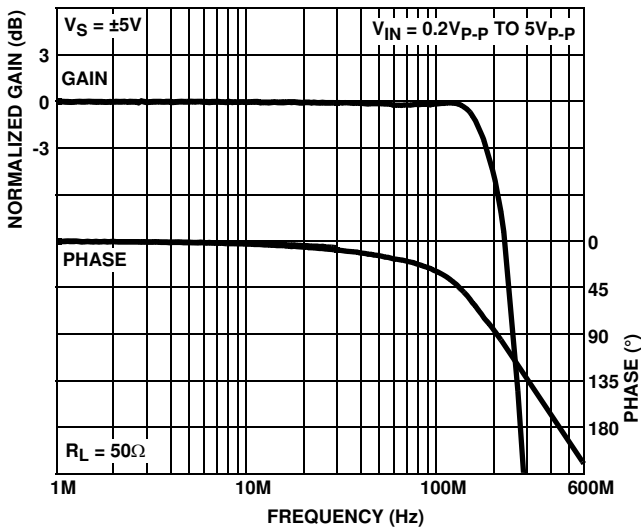

FIGURE 16. FREQUENCY RESPONSE

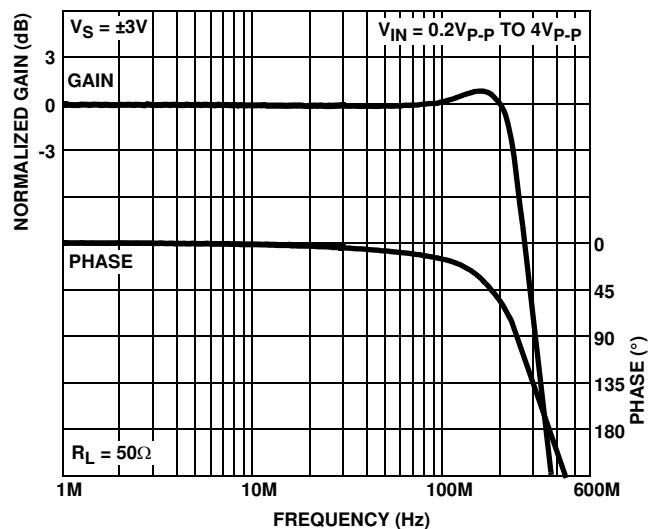

FIGURE 17. FREQUENCY RESPONSE

Typical Performance Curves $T_A = +25^\circ\text{C}$, Unless Otherwise Specified (Continued)

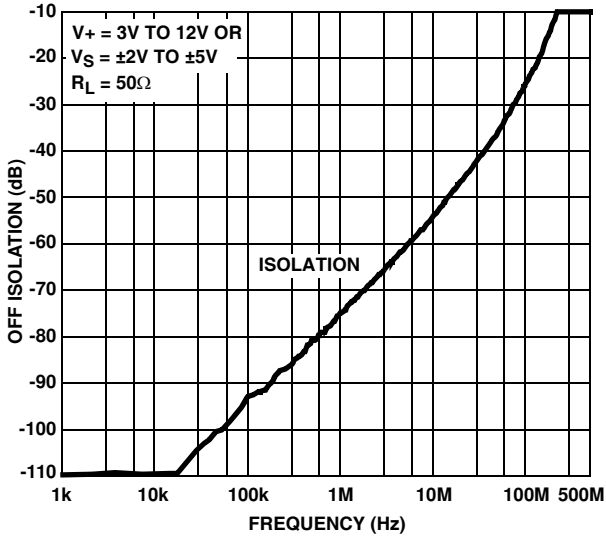

FIGURE 18. OFF ISOLATION

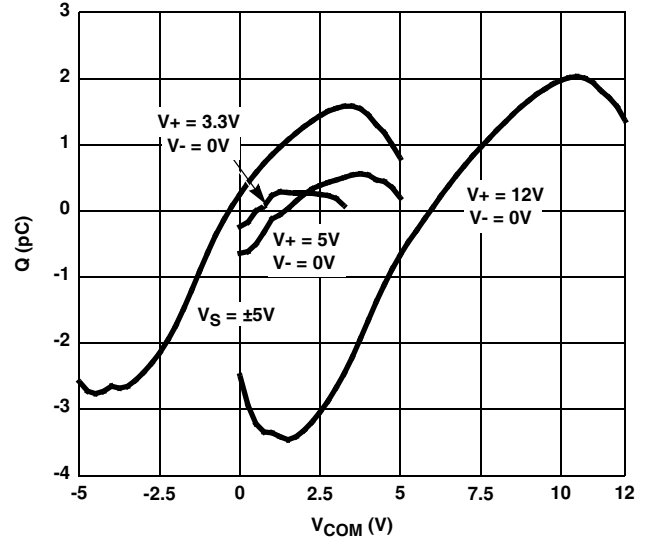

FIGURE 19. CHARGE INJECTION vs SWITCH VOLTAGE

Die Characteristics

SUBSTRATE POTENTIAL (POWERED UP):

V_-

TRANSISTOR COUNT:

193

PROCESS:

Si Gate CMOS

**Shrink Small Outline Plastic Packages (SSOP)
Quarter Size Outline Plastic Packages (QSOP)**

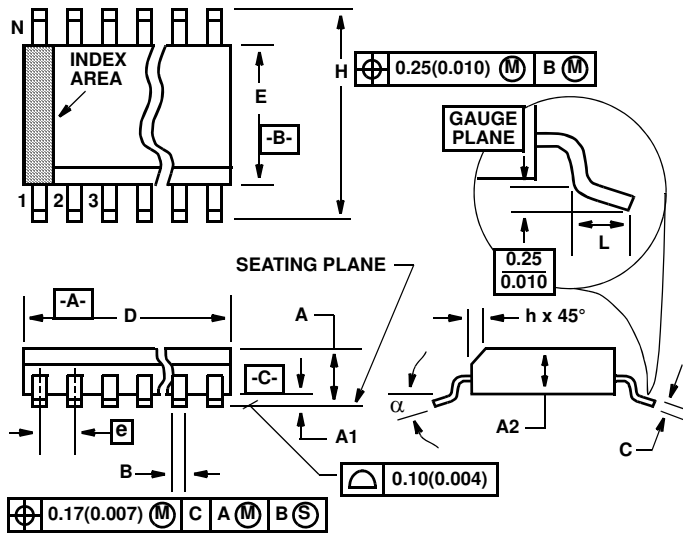

M16.15A
16 LEAD SHRINK SMALL OUTLINE PLASTIC PACKAGE
(0.150" WIDE BODY)

SYMBOL	INCHES		MILLIMETERS		NOTES
	MIN	MAX	MIN	MAX	
A	0.061	0.068	1.55	1.73	-
A1	0.004	0.0098	0.102	0.249	-
A2	0.055	0.061	1.40	1.55	-
B	0.008	0.012	0.20	0.31	9
C	0.0075	0.0098	0.191	0.249	-
D	0.189	0.196	4.80	4.98	3
E	0.150	0.157	3.81	3.99	4
e	0.025 BSC		0.635 BSC		-
H	0.230	0.244	5.84	6.20	-
h	0.010	0.016	0.25	0.41	5
L	0.016	0.035	0.41	0.89	6
N	16		16		7
α	0°	8°	0°	8°	-

NOTES:

1. Symbols are defined in the "MO Series Symbol List" in Section 2.2 of Publication Number 95.
2. Dimensioning and tolerancing per ANSI Y14.5M-1982.
3. Dimension "D" does not include mold flash, protrusions or gate burrs. Mold flash, protrusion and gate burrs shall not exceed 0.15mm (0.006 inch) per side.
4. Dimension "E" does not include interlead flash or protrusions. Interlead flash and protrusions shall not exceed 0.25mm (0.010 inch) per side.
5. The chamfer on the body is optional. If it is not present, a visual index feature must be located within the crosshatched area.
6. "L" is the length of terminal for soldering to a substrate.
7. "N" is the number of terminal positions.
8. Terminal numbers are shown for reference only.
9. Dimension "B" does not include dambar protrusion. Allowable dambar protrusion shall be 0.10mm (0.004 inch) total in excess of "B" dimension at maximum material condition.
10. Controlling dimension: INCHES. Converted millimeter dimensions are not necessarily exact.

Rev. 2 6/04

Thin Shrink Small Outline Plastic Packages (TSSOP)

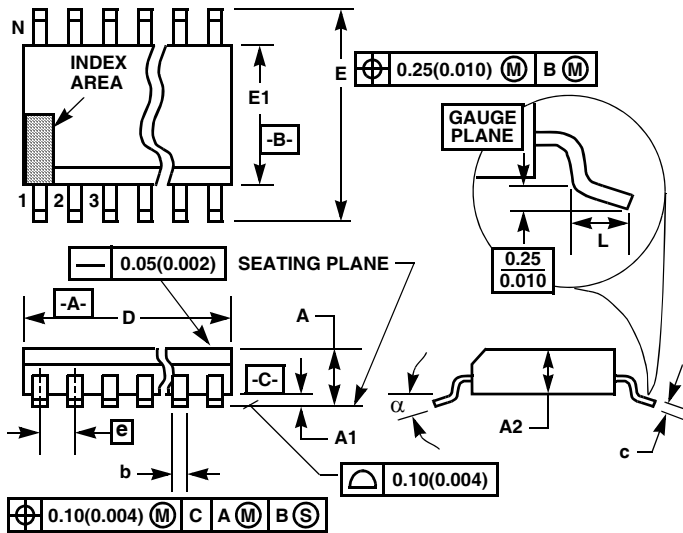

M16.173
16 LEAD THIN SHRINK SMALL OUTLINE PLASTIC PACKAGE

SYMBOL	INCHES		MILLIMETERS		NOTES
	MIN	MAX	MIN	MAX	
A	-	0.043	-	1.10	-
A1	0.002	0.006	0.05	0.15	-
A2	0.033	0.037	0.85	0.95	-
b	0.0075	0.012	0.19	0.30	9
c	0.0035	0.008	0.09	0.20	-
D	0.193	0.201	4.90	5.10	3
E1	0.169	0.177	4.30	4.50	4
e	0.026 BSC		0.65 BSC		-
E	0.246	0.256	6.25	6.50	-
L	0.020	0.028	0.50	0.70	6
N	16		16		7
α	0°	8°	0°	8°	-

NOTES:

1. These package dimensions are within allowable dimensions of JEDEC MO-153-AB, Issue E.
2. Dimensioning and tolerancing per ANSI Y14.5M-1982.
3. Dimension "D" does not include mold flash, protrusions or gate burrs. Mold flash, protrusion and gate burrs shall not exceed 0.15mm (0.006 inch) per side.
4. Dimension "E1" does not include interlead flash or protrusions. Interlead flash and protrusions shall not exceed 0.15mm (0.006 inch) per side.
5. The chamfer on the body is optional. If it is not present, a visual index feature must be located within the crosshatched area.
6. "L" is the length of terminal for soldering to a substrate.
7. "N" is the number of terminal positions.
8. Terminal numbers are shown for reference only.
9. Dimension "b" does not include dambar protrusion. Allowable dambar protrusion shall be 0.08mm (0.003 inch) total in excess of "b" dimension at maximum material condition. Minimum space between protrusion and adjacent lead is 0.07mm (0.0027 inch).
10. Controlling dimension: MILLIMETER. Converted inch dimensions are not necessarily exact. (Angles in degrees)

Rev. 1 2/02

All Intersil U.S. products are manufactured, assembled and tested utilizing ISO9000 quality systems. Intersil Corporation's quality certifications can be viewed at www.intersil.com/design/quality

Intersil products are sold by description only. Intersil Corporation reserves the right to make changes in circuit design, software and/or specifications at any time without notice. Accordingly, the reader is cautioned to verify that data sheets are current before placing orders. Information furnished by Intersil is believed to be accurate and reliable. However, no responsibility is assumed by Intersil or its subsidiaries for its use; nor for any infringements of patents or other rights of third parties which may result from its use. No license is granted by implication or otherwise under any patent or patent rights of Intersil or its subsidiaries.

For information regarding Intersil Corporation and its products, see www.intersil.com