

Quick Start Guide

RL78/G15
Fast Prototyping Board

(1) Checking out the video guide

A video is available to help you get started with Fast Prototyping Board for RL78 Family. The QR code for the video is at right.

You can also check the board's full specifications on the Renesas Web site.

URL: https://www.renesas.com/rl78g15_fpb



(2) Package components

RL78/G15 Fast Prototyping Board (RTK5RLG150C00000BJ) and Quick Start Guide (this document)

(3) Table of board specifications

Item	Specification
Evaluation MCU RL78/G15	Part No.: R5F12068ASP; package: 20-pin LSSOP On-chip memory: 8-KB ROM, 1-KB RAM, 1-KB data flash memory
Push switches	Reset switch x 1, user switch x 1
LEDs	Power indicator: green x 1, user: green x 2
Pmod™ connectors	Connectors: Angle type, 12 pins x 1
Arduino™ connectors	Connectors: 6 pins x 1, 8 pins x 2, 10 pins x 1 The interfaces are compatible with Arduino™ UNO R3.

(4) Parts layout

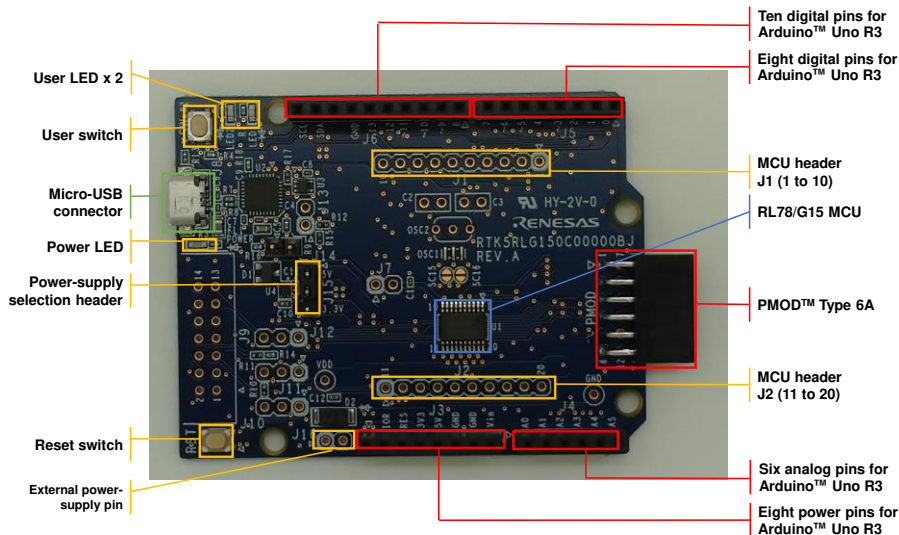

(5) Pmod™ interface

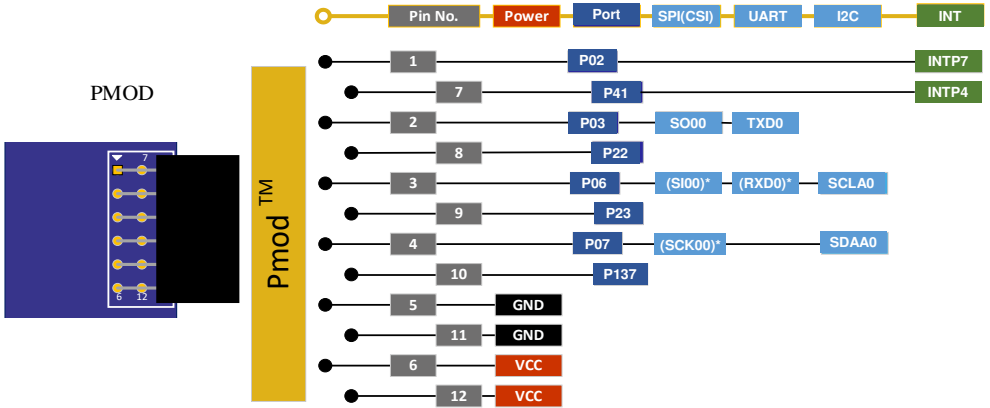

*requires switching the wiring by using the short-circuit pads.

(6) Arduino™ interface

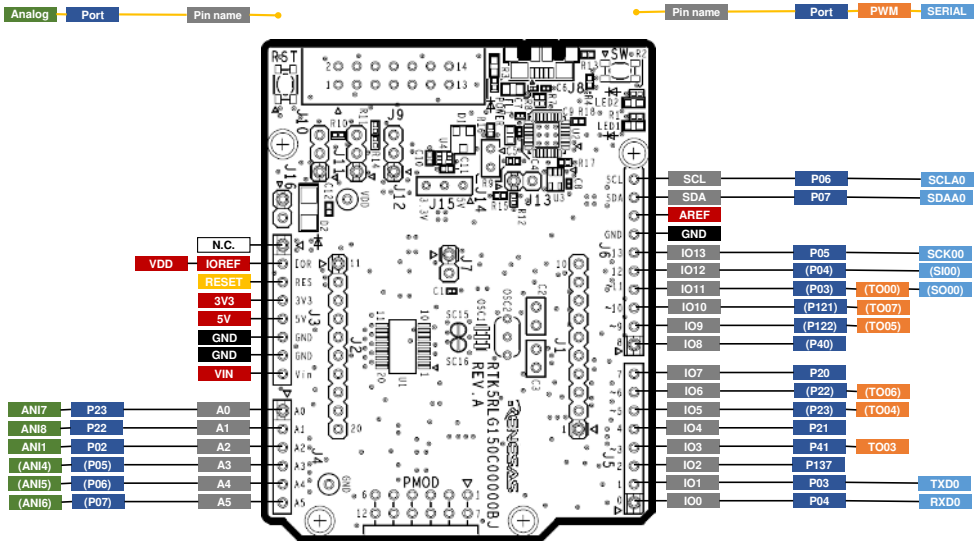

Short-circuit the short-circuit pads for signals with names enclosed in parentheses, “()”.