

Connector 120591-1 (Through Hole)

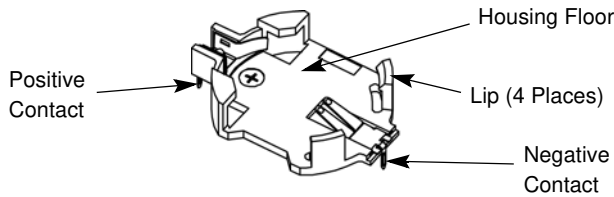

Connector 796136-1 (Surface Mount)

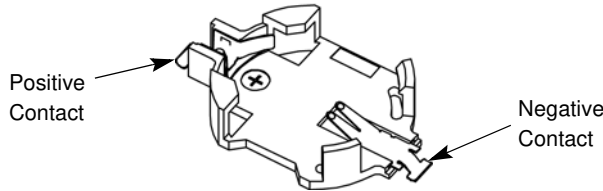

Figure 1

1. INTRODUCTION

Top-Load Battery Connectors 120591-1 (with through hole contacts) and 796136-1 (with surface mount contacts) are used to provide a back-up power source for pc board applications. These connectors accept all CR2032 lithium ion batteries.

2. DESCRIPTION

Each connector consists of a housing with a positive contact and a negative contact. The floor of the housing is embossed with a '+' to designate the positive contact. The connector features four lips for positive retention of the battery.

3. BATTERY INSTALLATION

The following procedure assumes that the connector is properly installed onto the pc board.

Refer to Figure 2, and install the battery into the connector as follows:

1. Support the connector by grasping the positive end of the connector.



The connector must be supported, otherwise damage to the soldered contacts could occur.

2. While supporting the connector, hold the battery at an angle with the positive side facing up, and slide the battery under the lips at the positive end of the connector.



Positive side of battery is marked with a '+'.

3. Gently push the battery onto the floor of the housing until the battery is fully seated. There should be an audible "snap."

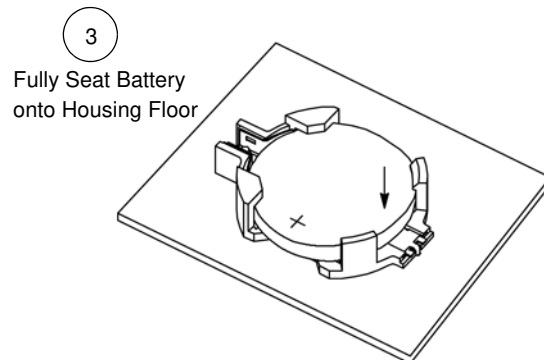
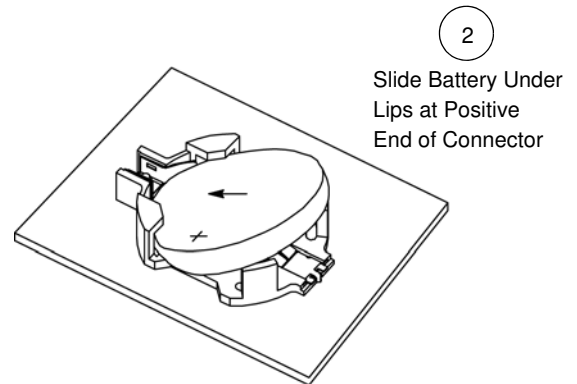
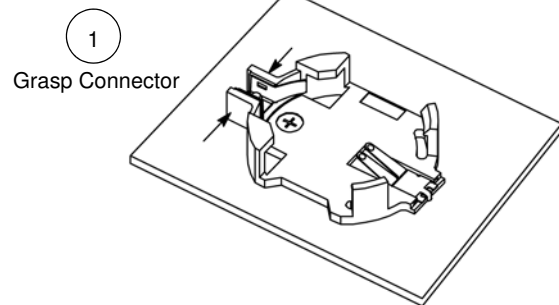

Figure 2

4. BATTERY REMOVAL

Remove the battery from the connector as follows:

1. Support the connector by grasping the 'positive' end of the connector.



The connector must be supported, otherwise damage to the soldered contacts could occur.

2. While supporting the connector, simultaneously push the battery toward the positive end of the connector, and slightly move the lips at the negative end of the connector away from the battery. Hold in this position, and lift the battery.

3. Pull the battery from the connector.

5. REVISION SUMMARY

Since the previous version of this document, the following changes were made:

- Corrected grammar in first sentence
- Updated document to corporate requirements