

# SERPAC C8

Electronic Enclosures

**NOTES:**

1) When machine or I-plates modifications are required, use the center of the enclosure to dimension.

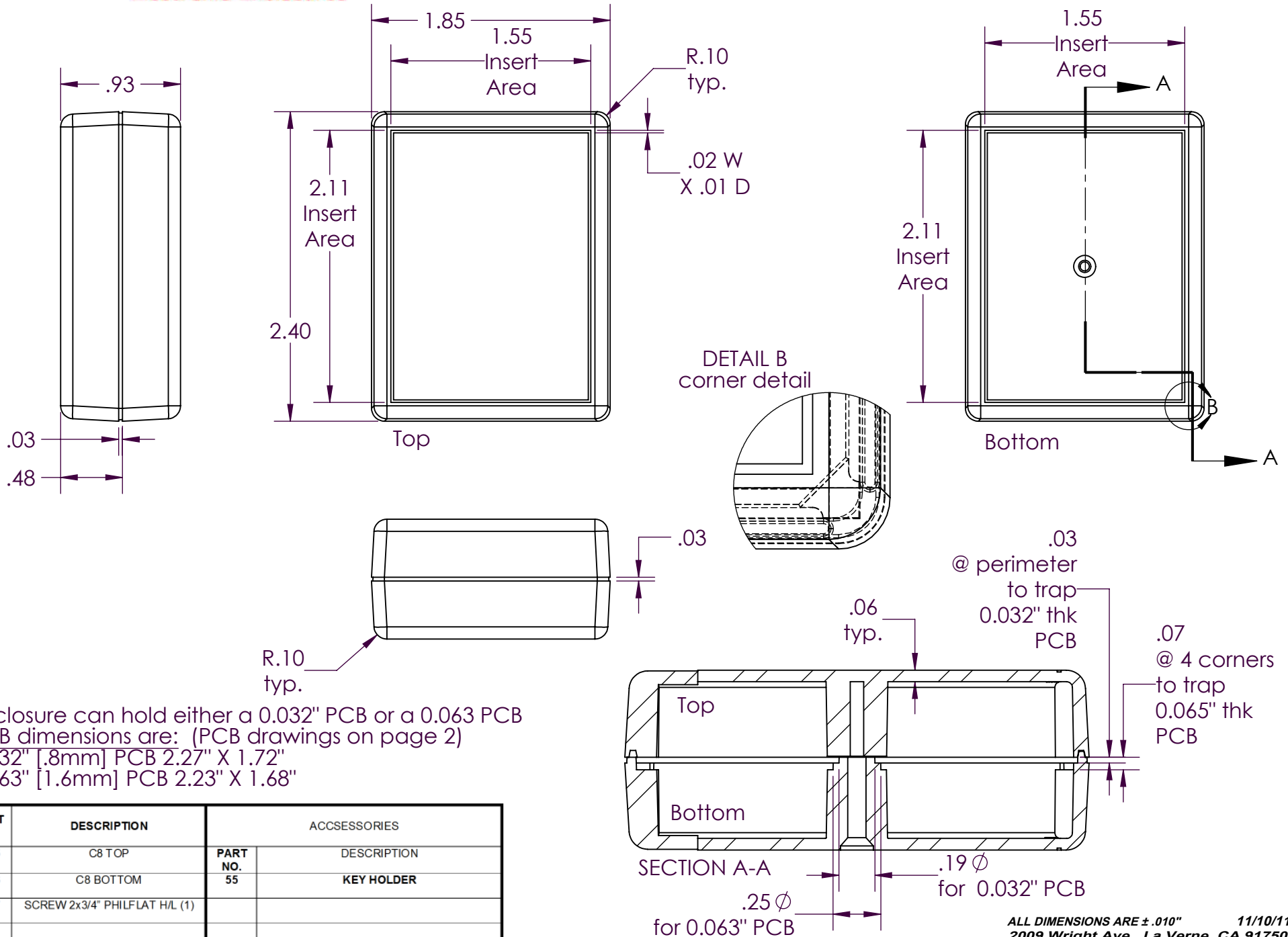

Enclosure can hold either a 0.032" PCB or a 0.063 PCB  
 PCB dimensions are: (PCB drawings on page 2)  
 0.032" [.8mm] PCB 2.27" X 1.72"  
 0.063" [1.6mm] PCB 2.23" X 1.68"

PART NO.	DESCRIPTION	ACCESSORIES	
1005	C8 TOP	PART NO.	DESCRIPTION
1006	C8 BOTTOM	55	KEY HOLDER
6007	SCREW 2x3/4" PHILFLAT H/L (1)		

# SERPAC CIRCUIT BOARD C8

Electronic Enclosures

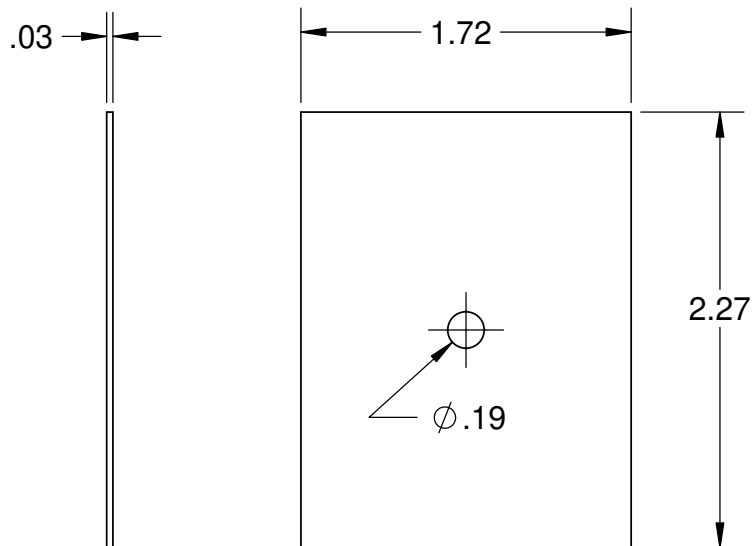

**.032 board**

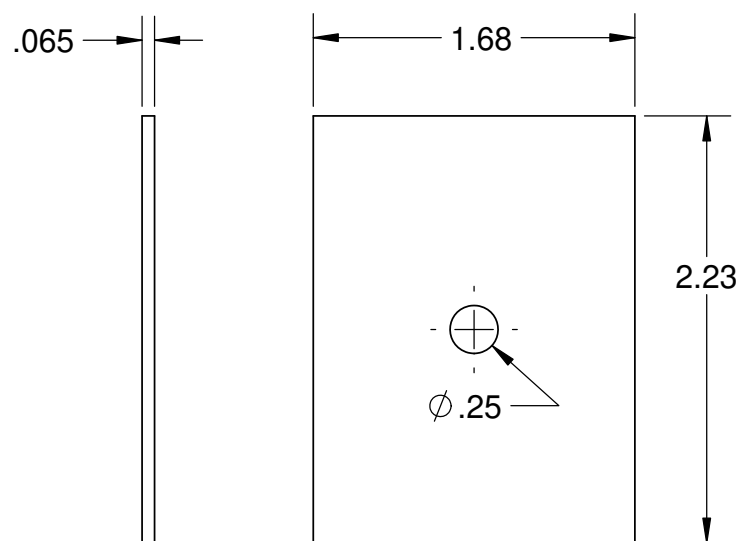

**.065 board**

**NOTES:**  
These are suggested dimensions.  
Plastic parts have a  $\pm 0.010$ " manufacturing tolerance.