

THIS DRAWING IS UNPUBLISHED. RELEASED FOR PUBLICATION
 © COPYRIGHT By - ALL RIGHTS RESERVED.

REVISIONS				
P	LTR	DESCRIPTION	DATE	APVD
J		REVISED PER ECO-16-004945	13OCT2016	RS MZ

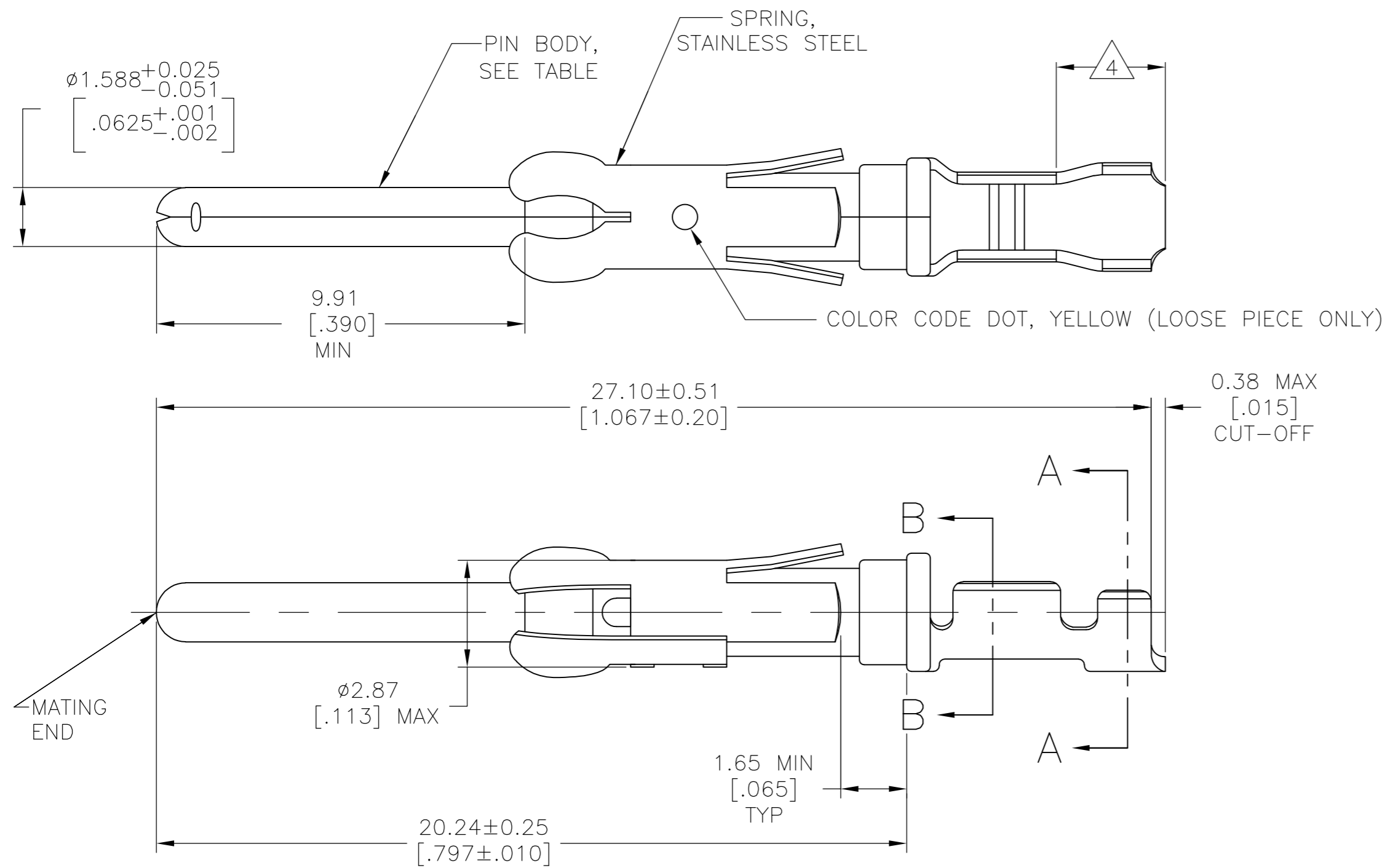

10 1.27µm [.000050] MIN TIN PER MIL-T-10727 OVER
 1.27µm [.000050] MIN NICKEL PER QQ-N-290.

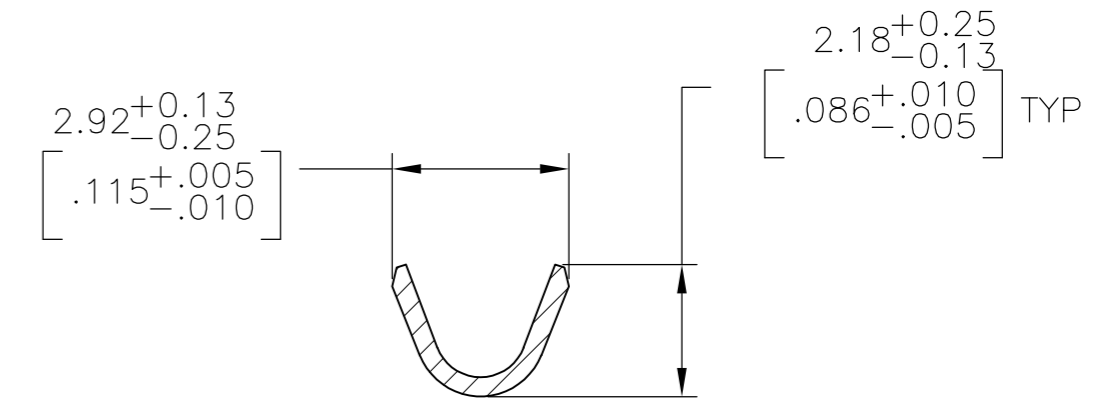

SECTION A-A

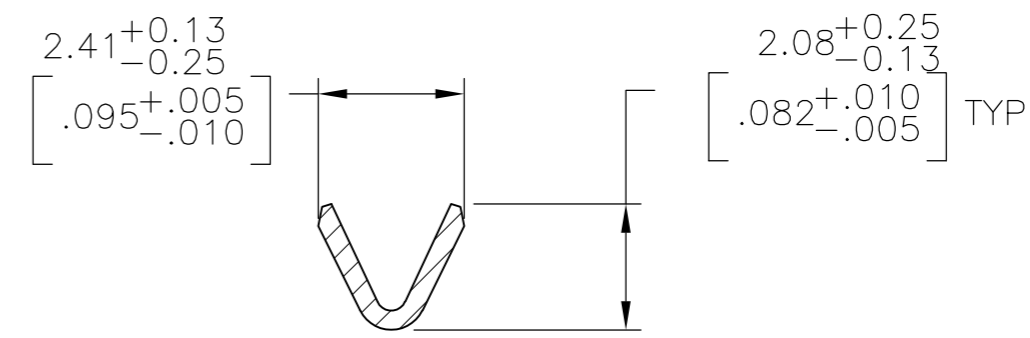

SECTION B-B

- 1 0.76µm [.000030] MIN PRECIOUS METAL PLATE ON MATING END FOR A LENGTH OF 5.08 [.200] MIN WITH 1.27µm [.000050] MIN MATTE TIN PLATE IN WIRE CRIMP AREA, BOTH OVER 1.27µm [.000050] MIN NICKEL PLATE. CONFORMS TO THE REQUIREMENTS OF TYCO ELECTRONICS PRODUCT SPEC 108-10042, BASED ON EIA/ECA-364-1000.01 (CONTROLLED ENVIRONMENT APPLICATIONS),
- 2 0.76µm [.000030] MIN PRECIOUS METAL PLATE ON MATING END FOR A LENGTH OF 5.08 [.200] MIN WITH A UNIFORM GRADIENT TO 0.25µm [.000010] MIN ON REMAINDER, OVER 1.27µm [.000050] MIN NICKEL PLATE. GOLD FLASH ALL OVER. CONFORMS TO THE REQUIREMENTS OF TYCO ELECTRONICS PRODUCT SPEC 108-10042, BASED ON EIA/ECA-364-1000.01 (CONTROLLED ENVIRONMENT APPLICATIONS).
- 3 0.38µm [.000015] MIN GOLD PER MIL-G-45204 ON MATING END FOR A LENGTH OF 5.08 [.200] MIN 1.27µm [.000050] MIN MATTE TIN PLATE IN WIRE CRIMP AREA, BOTH OVER 1.27µm [.000050] MIN NICKEL PER QQ-N-290.
- 4 GOLD PLATING NOT REQUIRED IN THIS AREA.
- 5 1.27µm [.000050] MIN GOLD PER MIL-G-45204 ON MATING END FOR A LENGTH OF 5.08 [.200] MIN WITH GOLD FLASH ON THE REMAINDER OVER 1.90µm [.000075] MIN NICKEL PER QQ-N-290.
- 6 1.27µm [.000050] MIN TIN-LEAD PER MIL-T-10727 OVER 1.27µm [.000050] MIN NICKEL PER QQ-N-290.
- 7 WIRE RANGE 24-20 AWG.
- 8 INSULATION RANGE 1.02[.040]-2.03[.080] DIA.
- 9 0.38µm [.000015] MIN GOLD PER MIL-G-45204 ON MATING END FOR A LENGTH OF 5.08 [.200] MIN, 1.27µm [.000050] MIN TIN-LEAD PER MIL-T-10727 FOR A LENGTH OF 5.69 [.224] MIN ON OPPOSITE END, BOTH OVER 1.27µm [.000050] MIN NICKEL PER QQ-N-290 ON ENTIRE CONTACT.

	SMALL PACK	10	BRASS	2-66102-5 OR 2-66102-6	1-66103-9
	STANDARD	10	BRASS	2-66102-5 OR 2-66102-6	1-66103-8
	SMALL PACK	1	BRASS	66102-4	1-66103-7
	SMALL PACK	3	BRASS	66102-3	1-66103-6
	SMALL PACK	6	BRASS	66102-2	1-66103-5
	SMALL PACK	2	BRASS	66102-1	1-66103-4
OBSOLETE	STANDARD	9	BRASS	2-66102-3	1-66103-3
OBSOLETE	STANDARD	1	PHOSPHOR BRONZE	2-66102-2	1-66103-2
OBSOLETE	STANDARD	6	PHOSPHOR BRONZE	2-66102-1	1-66103-1
	STANDARD	1	BRASS	66102-4	66103-4
	STANDARD	3	BRASS	66102-3	66103-3
	STANDARD	6	BRASS	66102-2	66103-2
	STANDARD	2	BRASS	66102-1	66103-1
	PACKAGING TYPE	BODY FINISH	BODY MATERIAL	STRIP P/N REF	PART NO

THIS DRAWING IS A CONTROLLED DOCUMENT.		DWN	06/01/92		
		L.SIPE	6-11-92		
DIMENSIONS: mm [INCHES]		CHK	W.LENKER	PIN ASSEMBLY, LOOSE PIECE, TYPE III+	
		APVD	G.STEINHAUER		
TOLERANCES UNLESS OTHERWISE SPECIFIED:		PRODUCT SPEC		SIZE	CAGE CODE
0 PLC ± -		APPLICATION SPEC		A2	00779
1 PLC ± -				DRAWING NO	RESTRICTED TO
2 PLC ± 0.13 [.005]				C=66103	-
3 PLC ± -				SCALE	SHEET
4 PLC ± -				8:1	1 of 1
ANGLES ± -				REV	J
MATERIAL	FINISH	WEIGHT			
SEE CALLOUTS	SEE CALLOUTS	CUSTOMER DRAWING			