

REVISONS		DATE	BY	APPV
NO.	DESCRIPTION			
1	REV PER ECO-15-016251	13NOV15	KG	CD

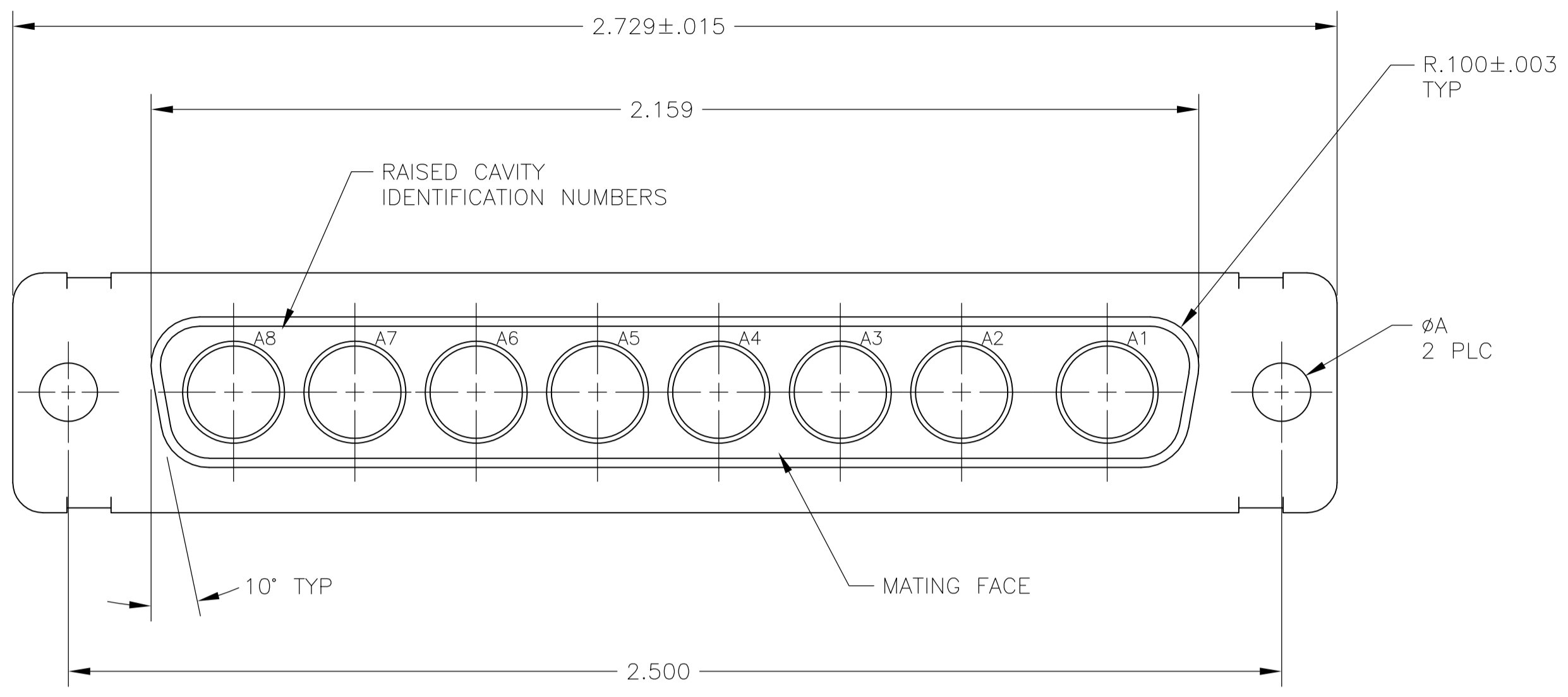

- THIS CONNECTOR ACCEPTS (8) POWER 8, OR COAX SOCKET CONTACTS IN POSITIONS A1 THRU A8, PURCHASED SEPARATELY.
- STEEL PER ASTM-A-109.
- BRASS PER MIL-C-50 AND ASTM-B-36 UNS NO. C26000.
- FINISH: CADMIUM PLATED PER QQ-P-416.
- GOLD PLATED PER ASTM-B-488 TYPE 3, CODE C, CLASS 1.25 OVER COPPER PER MIL-C-14550, CLASS IV.
- FINISH: TIN PER ASTM-B-545 .000400 MIN THK OVER COPPER PER AMS2418 .000050 MIN THK.
- FINISH: ZINC PLATED PER ASTM-B-633 .000200-.000400 THK WITH SUPPLEMENTARY CHROMATE (Cr3+).

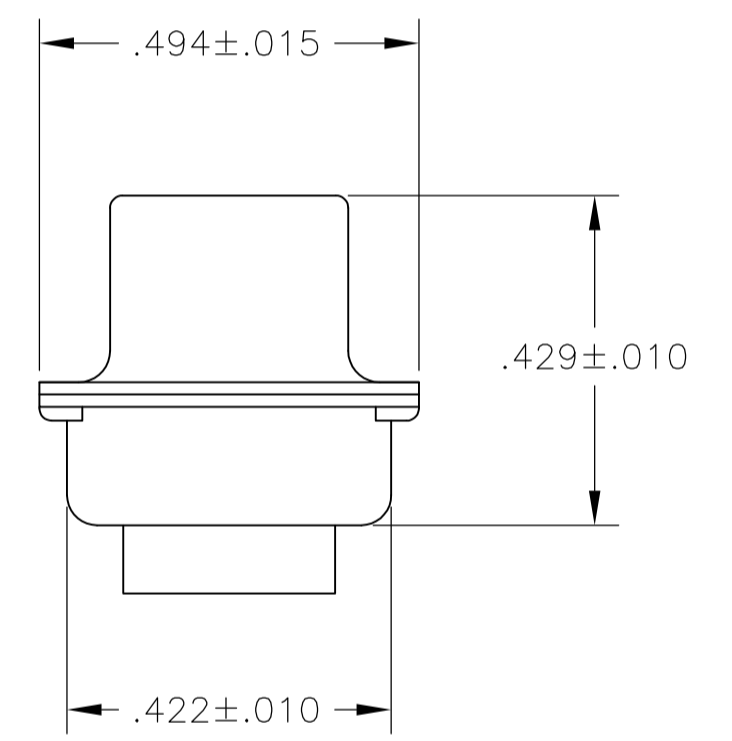
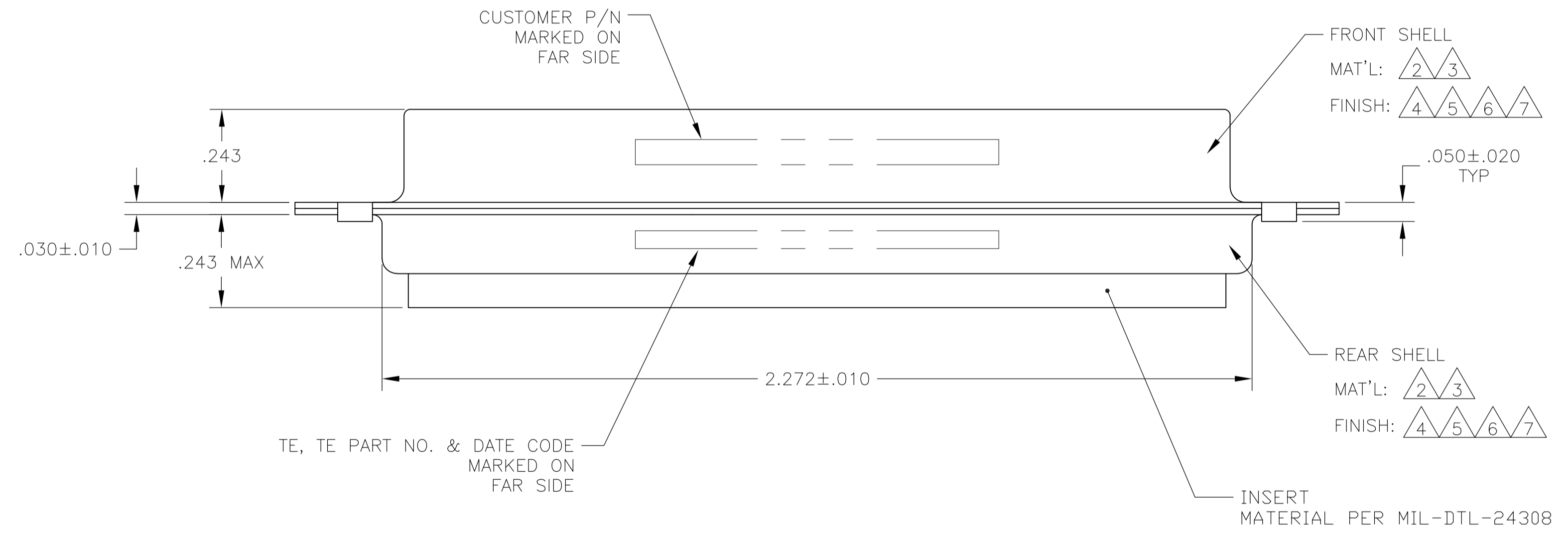

PRELIMINARY- NOT RELEASED FOR PRODUCTION

REMARKS	ØA	CUSTOMER PART NO.	PART NO.
2, 6	.120	-	5-445730-5
2, 7	.120	-	5-445730-1
2, 4	.120	13508255	445730-8
3, 5	.120	ST81D284-002	445730-7
3, 5	.120	B010942-0042	445730-6
2, 6	.120	-	445730-5
3, 5	.154	311P405-15S-B-15	445730-4
3, 5	.120	311P405-15S-B-12	445730-3
2, 4	.120	2037AS246-01,00779,3003	445730-2
2, 4	.120	-	445730-1

THIS DRAWING IS A CONTROLLED DOCUMENT. **STE** TE Connectivity

DIMENSIONS: INCHES	TOLERANCES UNLESS OTHERWISE SPECIFIED:	0 PLC ± -	1 PLC ± -	2 PLC ± -	3 PLC ± .005	4 PLC ± -	ANGLES ± 0°, 30'
MATERIAL	FINISH	WEIGHT	SIZE	CAGE CODE	DRAWING NO.	RESTRICTED TO	
-	-	-	A1	00779	445730	-	

CUSTOMER DRAWING SCALE 4:1 SHEET 1 OF 1 REV T