

DETAIL 1
SCALE: 10:1

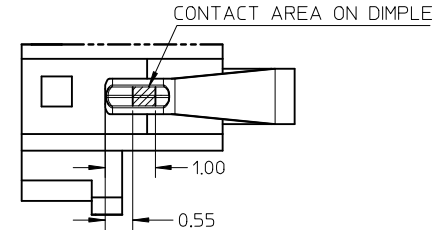

DETAIL 2
SCALE: 10:1

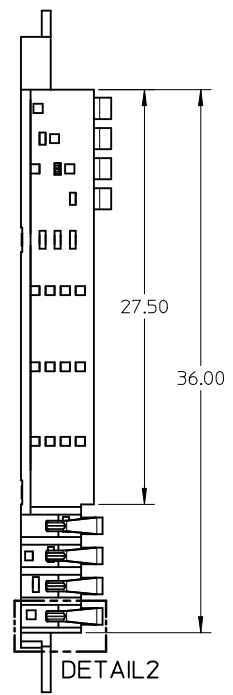

DETAIL 2

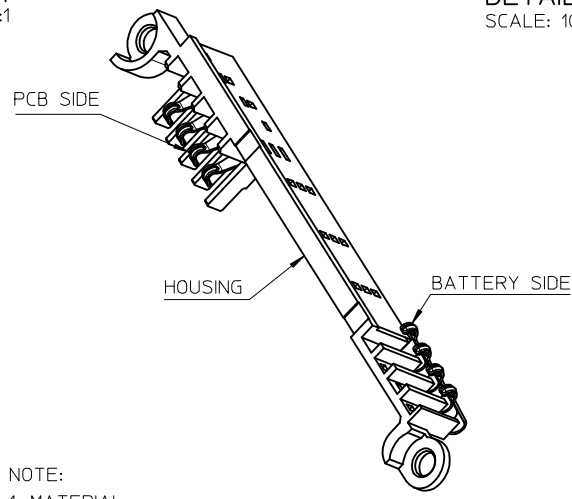

- NOTE:
- MATERIAL:
HOUSING: LCP, UL 94V-0, COLOR IS IVORY WHITE
TERMINAL: COPPER ALLOY C17200 TM06, THICKNESS IS 0.15 mm
 - FINISH:
CONTACT AREA ON DIMPLE : 30~55μ" GOLD PLATING OVER 50~150μ" NICKEL
 - WORKING RANGE AND FORCE (TRAVEL/FORCE):
BATTERY SIDE: 1.05mm/115±30g, 1.45mm/210gMAX
PCB SIDE: 0.80mm/60±30g, 1.05mm/130gMAX
 - PRODUCT SPECIFICATION: PS-105077-001
 - COMPLIANT TO RoHS DIRECTIVE 2002/95/EC AND ELV DIRECTIVE 2000/53/EC
 - DATE CODE: * ** ** (5 DIGITS)
DAY
MONTH
YEAR

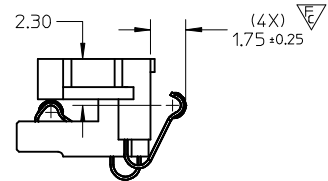

NEW RELEASE IEC NO: SH2010-0121 DRWN: YPWU CH'KD: APPR: WEDENG	2009/09/24 2009/10/07 2009/10/21	QUALITY SYMBOLS ▽ F=0 ▽ F=2 ▽ F=0	GENERAL TOLERANCES (UNLESS SPECIFIED) mm INCH 4 PLACES ± --- ± --- 3 PLACES ± --- ± --- 2 PLACES ± 0.20 ± --- 1 PLACE ± 0.3 ± --- ANGULAR ± 2 °	DIMENSION STYLE MM ONLY DRAWN BY DATE JYANG13 2008/09/04 CHECKED BY DATE YLZHU02 2008/09/04 APPROVED BY DATE HWWANG 2008/09/04 MATERIAL NO. 1050770001	SCALE 4:1 DESIGN UNITS METRIC THIRD ANGLE PROJECTION	TITLE SALES DRAWING 4 PIN COMPRESSION BATTERY CONNECTOR MOLEX INCORPORATED DOCUMENT NO. SD-105077-001	SHEET NO. 1 OF 1
	DRAFT WHERE APPLICABLE MUST REMAIN WITHIN DIMENSIONS	THIS DRAWING CONTAINS INFORMATION THAT IS PROPRIETARY TO MOLEX INCORPORATED AND SHOULD NOT BE USED WITHOUT WRITTEN PERMISSION					
	REV A						